

Deposit Manual

for Knorr brake calipers only

SAF-HOLLAND Deposit Manual

- Appropriate disposal where the products or components cannot be reused
- Prevention of safety-critical products being misused by non-authorized parties
- Environmental Responsibility

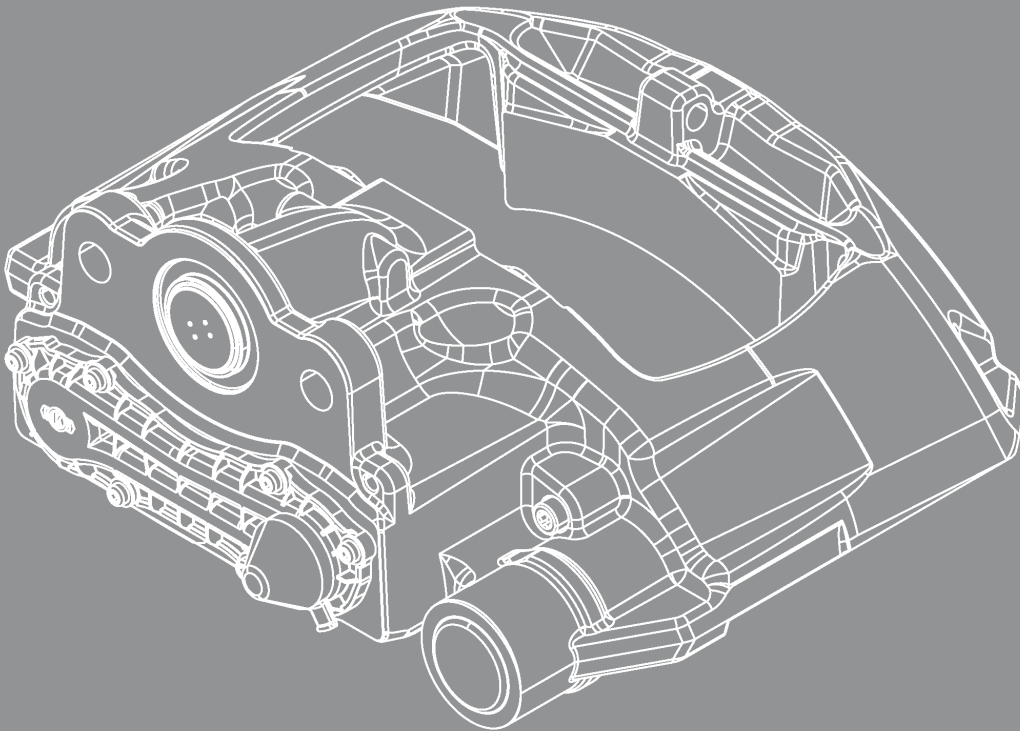

| | Page |
|--------------------------------------|-------------|
| 1 SAF-HOLLAND Deposit Manual | |
| 1.1 Introduction | 3 |
| 1.2 Core Program | 3 |
| 1.3 Core Accounting | 4 |
| 1.4 Core Return | 5 |
| 2 Core allocation | |
| 2.1 Deposit capability | 6 |
| 2.2 Brake caliper / Exchange caliper | 6 |
| 2.3 Disposal / Deposit system | 7-8 |
| 3 Core Reports | 8 |

Disclaimer:

The information contained in this document is intended for the exclusive use of trained persons within the commercial vehicle industry, and must not be passed on to any third party. All recommendations regarding products and their servicing or usage are with reference to Knorr-Bremse products and should not be considered applicable to products from other manufacturers. Any legal disputes arising from the use of this information shall be subject to German law.

This information does not purport to be all-inclusive and no responsibility is assumed as a result of its use. We cannot accept any liability nor offer any guarantee regarding data accuracy, completeness or timeliness. The information does not represent any guarantee or ensured characteristics of the Products or Systems described.

No liability can be accepted based on the information, its use, recommendations or advice provided. In no event may we be held liable for any damage or loss except in the case of wilful intent or gross negligence on our part, or if any mandatory legal provisions apply.

This disclaimer is an English translation of a German text, which should be referred to for all legal purposes.

Domestic place of general jurisdiction for any disputes resulting of the use of information provided herein is Aschaffenburg.

1.1 Introduction

In the coming years SAF-HOLLAND is willing to increase its efforts to collect old units / back from the market.

The main driving forces behind this philosophy are:

- To prevent broken, damaged or worn out safety-critical products being misused for reconditioning activities by non-authorized parties.
- To ensure the availability of high quality manufactured products in the market place and thereby protect customers from potential safety issues that could arise from non-authorized parties repairing or reconditioning old units.
- Environmental responsibilities:
Minimizing pollution; minimizing waste; ensuring appropriate disposal where the products or components cannot be reused.

In order to support SAF-HOLLAND with this approach, it is therefore important that the used parts are returned by following the SAF-HOLLAND deposit system and procedures.

1.2 Core return programm

The core program specifies how:

- Core accounts work
- Core relevant material
- Core accounting, core return and month-end processing works.

Within the SAF-HOLLAND deposit system, core relevant parts are surcharged at the time of sale with a deposit value – usually as a separate line on the invoice – and corresponding old units need to be returned to SAF-HOLLAND within a period of 12 months from the end of the invoicing month. Payment of the deposit is subject to the same payment terms as any other invoice.

If returned during this time, the deposit value will be credited to the customer if eligible - meaning the customer has made a purchase against the return within the same core group. In case of over-return, the value will remain in the deposit account for a maximum period of 24 months until the customer makes another purchase within the same core group.

The respective part numbers can be found in the SAF-HOLLAND cross reference list (see page 6 – deposit value €100). The sales price of the SAF-HOLLAND products with deposit surcharge is based on the assumption that a deposit unit will be returned to SAF-HOLLAND for each unit purchased.

For additional information please contact your SAF-HOLLAND account manager.

In order to ensure that a core product that is part of the deposit system will be accepted for core credit, it must be returned fully assembled and in a suitable condition.

See Core Return section of this manual for further details (page 5).

1.3 Core Accounting

SAF-HOLLAND will maintain a customer core account showing the balance between core products purchased and returned.

Core statements will be provided monthly showing any transaction during the month, the month end balance and core due for upcoming months. Returned core during that month will be credited if the customer is eligible for it. The credit is always applied against the oldest outstanding purchase within the same core group. See Core Reports section of this manual.

If you have any additional question please contact your SAF-HOLLAND account manager or the SAF-HOLLAND customer support.

If the core is not returned to SAF-HOLLAND within the defined time window the core value will be expire and be deleted from the core account.

For expired and rejected cores, SAF-HOLLAND reserves the right to scrap the material.

1.4 Core Return

How to return cores via SAF-HOLLAND?

- A core indication form is available from your local SAF-HOLLAND contact or representative – see example in appendix of this manual or – as preferred – by using the electronic version at www.safholland.com.
- Complete the form, send a copy to your contact at SAF-HOLLAND and attach another copy to the return. Please ensure that the approximate total weight has been entered on the form.
Note: It is necessary to have one form placed in an envelope and attached to each container. Failure to do this or any required information missing on the form, will result in a delay in having the return collected and processed in the system.
- SAF-HOLLAND will add an internal reference number for each delivery when processing the returned core into the system. For this purpose it is necessary that the current date is provided at the time when the copy of the request form is sent to SAF-HOLLAND. SAF-HOLLAND will email an acknowledgement after the core return has been processed. The reference number can be used as a reference later.

Pack old units into suitable containers, taking care to avoid damage to units both when packing and during transit.

Please be aware that all returns of cores must be accompanied by a completed form. This must be attached to each container, and SAF-HOLLAND needs to be informed at this time. Failure to do so may result in delays, and in core returns not being credited before expiration and hence surcharge / deposit will not be refunded.

Why would SAF-HOLLAND probably reject used units that have been returned

- No Goods Collection Request Form is attached to the returned core.

Core rejected by SAF-HOLLAND will be flagged with S for scrap on the core acknowledgement report. Accepted core will be flagged with G for good core. It is solely up to SAF-HOLLAND to decide whether a unit will be accepted or rejected.

What is a major damaged part?

Calipers with dents or holes in major body housing or castings.

What is an incomplete or disassembled condition?

- Calipers not returned complete that means e.g. without adjuster in place.
- 5-pieces-deposit-concept: incomplete return of the required single components (see pages 7+8)

Note:

SAF-HOLLAND accepts no liability for such disassembly activities and the workshop must ensure all safety practices are followed.

2.1 Deposit capability

- All Knorr-Brake Calipers (Truck and/or Trailer)
- All Knorr-Exchange Calipers (Truck and/or Trailer)
- Optional 5-pieces-deposit-concept: (see pages 7+8 for details)

1. Adjuster
2. Cover Plate
3. 2 Pins
4. Type Plate

Note:

If you do not send all 5 parts of the deposit-concept to us, we can not credit the value to your deposit account.

2.2 Exchange calipers available at SAF-HOLLAND

| Type | Remark | Knorr-No.: old | Knorr-No.: new | SAF-Part-No. | Suitable for |
|---------------|--------------------------|-----------------------------|----------------|--------------|--------------------------------------|
| SB6 left | 15° cylinder position | K002923 | K002923K50 | 05400100100 | all 15° Trailerbrakes |
| SB6 right | 15° cylinder position | K002924 | K002924K50 | 05400100200 | al 15° Trailerbrakes |
| SB6/SN6 left | 5° cylinder position | K013173/K003779/ K013203 | K013173K50 | 05400100300 | all 5° Trailerbrakes |
| SB6/SN6 right | 5° cylinder position | K013174/K003780/ K013204 | K013174K50 | 05400100400 | all 5° Trailerbrakes |
| SB/SN7 left | 0° cylinder position | K003783K003785 | K003783K50 | 05400100500 | all 0° Trailerbrakes |
| SB/SN7 right | 0° cylinder position | K003784/K003796 | K003784K50 | 05400100600 | all 0° Trailerbrakes |
| SN7 left | -12° cylinder position | K013181K003781 | K013181K50 | 05400100700 | all -12° Trailerbrakes |
| SN7 right | -12° cylinder position | K013182/K003782 | K013182K50 | 05400100800 | all -12° Trailerbrakes |
| SN7 left | 0° with Potentiometer | K003787 | K003787K50 | 05400100900 | SAF steered trailing axles MAN |
| SN7 right | 0° with Potentiometer | K003788 | K003788K50 | 05400101000 | SAF steered trailing axles MAN |
| SK7 right | 0° cylinder position | K012633 | K012633K50 | 05400101100 | all SK Trailer- brakes |
| SK7 left | 0° cylinder position | K012634 | K012634K50 | 05400101200 | all SK Trailer- brakes |

2.3 Steps for disposal / SAF-HOLLAND 5-pieces-deposit-concept

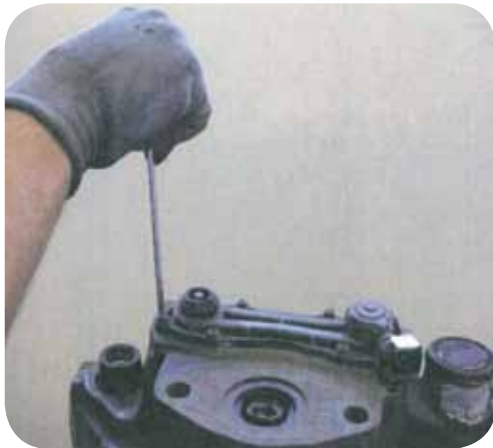

1. Dismount Cover Plate with screw driver.



2. Remove Cover Plate and chain.



3. Remove adjuster.
For easier removal please activate rocker arm.



4. Brake the 2 pins loose.



5. Fill up bushing with grease to pick the Pins and remove Pin 1.



6. Remove Pin 2. For easier removal activate rocker arm.



Detach Typ Plate.



After removal of Adjuster, Cover Plate, 2 Pins and the Type Plate, the Brake caliper could be disposed responsibly and according to local governmental and environmental regulations.

Please send Adjuster, Cover Plate, 2 Pins and the Type Plate in an appropriate container to the following address:

SAF-HOLLAND GmbH
c/o Teamlog
Mr. Markus Prößler
Germanenstr. 30
63741 Aschaffenburg

3 Core Reprts

Overview report

A monthly overview of your core account will be emailed to you by your responsible account manager.

The report includes newly supplied parts, returns and any other movements in your account.

In addition, the month-end account balance, expired or credited deposit values as well as a preview of the cores that will be due per month for the next 3 months are shown.

Headquarter:

Aftermarket EMEA:

SAF-HOLLAND GmbH
Germanenstr. 30
D-63741 Aschaffenburg
Deutschland
Tel. +49 6095 301 301
Fax +49 6095 301 494
originalparts@safholland.de

Aftermarket Americas:

SAF-HOLLAND USA, Inc.
1950 Industrial Blvd.
PO Box 425
Muskegon, MI 49443-0425
Tel. +1 231-773-3271
Fax +1 231-777-2515
info@safholland.com

Subsidiaries Europe:

Bulgaria

SAF-HOLLAND Bulgaria EOOD
Osmi Mart 22
9300 Dobrich
Tel. +359 58 690260
Fax +359 58 690262
Saf_trade@dobrich.net

Denmark

SAF-HOLLAND Denmark ApS
Fabriksvej 18
DK-6000 Kolding
Tel. +45 75 50 41 42
Fax +45 75 50 41 12
pb@safholland.dk

France

SAF-HOLLAND France SAS
Z.A. Ablis Nord, B.P. 48
F-78660 Ablis
Tel. +33 1-30 88 09 00
Fax +33 1-30 88 09 01
contact@safholland.fr

Italy

SAF-HOLLAND Italia S.R.L unipersonale
Via Pasteur 12/A
I-37135 Verona
Tel. +39 045 8250560
Fax +39 045 509789
info@safholland.it

Poland

SAF-HOLLAND Polska Sp.z o.o.
UL. 27 Stycznia 42/43
PL-64980 Trzcianka
Tel. +48 672166 -560 /-570
Fax +48 672166 -580
piuro@safholland.pl

Austria

SAF-HOLLAND Austria GmbH
Aura Business Center
Triesterstraße 10/4/1/5
2351 Wiener Neudorf
Tel. +43 2236-64650-0
Fax +43 2236-64650-44
office@safholland.at

Romania

SAF-HOLLAND Romania SRL
Str. Stefan cel Mare nr. 369
RO-507075 Ghimbav - Brasov
Tel. +40 268 258830
Fax +40 268 258012
saftradero@rdslink.ro

Spain

SAF-HOLLAND España S.L.
Polígono Industrial El Congost
Camí Ral 1 Nave F
E-08170 Montornés del Valles (Barcelona)
Tel. +34 93-8 46 81 11
Fax +34 93-8 46 79 79
info@safholland.es

Czech Republic

SAF-HOLLAND Czechia spol. s r.o.
Prumyslová 1152
CZ- 68601 Uherské Hradiste
Tel. +420 572 540 900
Fax +420 572 540 933
info@safholland.cz

Subsidiaries Worldwide:

Australia

SAF-HOLLAND (Aust.) Pty. Ltd.
 115 High Street
 PO Box 63
 Melton, Victoria, 3337, Australia
 Tel. +61 03 9743 6799
 Fax +61 03 9743 6763
enquiries@safholland.com.au

Brazil

SAF-HOLLAND do Brasil Ltda.
 Av. Emilio Marconato, 1000
 Galpao B-16
 Chácara Primavera
 13.820-000 Jaguariúna - Sao Paulo
 Tel. +55 19 3311 1555
 Fax +55 19 3311 1554
alexandre.sa@safholland.com.br

China

SAF-HOLLAND China
Xiamen Austin-Westran Machinery Co., Ltd.
 #1599 DongFu Road, DongFu industrial zone
 Haicang district, Xiamen
 361027 Fujian province
 Tel.+0086-592-6288891
 Fax.+0086-592-6288892
Evelyn.huang@safholland.cn

Japan

SAF-HOLLAND Nippon, Ltd.
 Shibuya Central Bldg
 3-14 Udagawacho
 Shibuya-Ku
 Tokyo 150-0042
 Tel. +81 3 3461 9130
 Fax +81 3 3463 1407
e-mail@nhl-shinko.co.jp

Canada

SAF-HOLLAND Canada, Ltd
 595 Athlone Ave.
 PO Box 698
 Woodstock ON. N4S 7Z5
 Tel. +1 519-537-2367
 Fax +1 519-537-7913
Paul.robb@safholland.com

Malaysia

SAF-HOLLAND (Malaxsia) SDN. BHD.
 Block A, Ascendas Logistics Hub
 16 Jalan TP6
 UEP Subang Jaya Industrial Park
 47620 Petaling Jaya
 Selangor Darul Ehsan
 Tel. +60 603-8024 3433
 Fax.+60 603-8024 3431
general@safholland.com.my

Mexico

SAF-HOLLAND International de Mexico S. de R.L. de C.V.
 Av. Paseo de las Palmas 405-301
 Torre Optima, Nivel 3
 Col. Lomas de Chapultepec
 CP: 11000, México, D.F.
 Tel. +52 (55) 54.56.86.41
 Fax +52 (55) 54 56.86.42
saleslatinamerica@safholland.com

Russia

SAF-HOLLAND Rus OOO
 Prospect Mira 68
 Stroenie 1a
 Office 21
 129110 Moscow
 Tel. +7(495)782-50-82
 Fax +7(495)987-45-24
saf-intcom@yandex.ru

South Africa

SAF-HOLLAND South Africa Ltd
 89 Jurie Street
 Alrode
 ZA-1451 Alberton (Johannesburg)
 Tel.+27 11 908 9201
 Fax+27 11 908 920
george@safhollandsa.co.za

Thailand

SAF-HOLLAND (Thailand) Co., Ltd.
 444 Olympia Thai Tower 15Fl.
 Ratchadaphisek Road Samsennok Huay Kwang
 Bangkok 10320
 Tel. +66 2-513-8758-9
 Fax +66 2 513-8757
general@safholland.co.th

Representatives:

BeNeLux

SAF Benelux

Nijverheidsweg 50
3770 Barneveld
Tel. +31 342 497881
Fax. +31 342 497960
information@safbenelux.nl

Finland

Oy ARNE STARA Ab

Kangastie/Movägen 14
68601 PIETARSAARI/ JAKOBSTAD
Tel. +35 867818750
Fax. +35 867818777
info@stara.com

Iceland

Stilling hf

Kletthals 5
IS – 110 Reykjavik
Tel. +354 520 8000
Fax. +354 520 8010
julius@stilling.is

New Zealand

Transpecs

Cnr Kerrs & Ash Rds., Wiri
AUCKLAND
Tel. +64 99807300
Fax. +64 99807306
mailroom@transpecs.co.nz

Norway

MoRek a.s

Industriv. 25
1481 Hagan
Tel. +47 6706 3500
Fax. +47 6706 3560
firmapost@morek.no

Portugal

Suspartes Lda.

Vila Amelia, Lote 107
2950-805 QUINTA DO ANJO
Tel. +351 212134710
Fax. +351 212103206
h.kemp@suspartes.pt

Sweden

Trailax AB

P.O. Box 2228
55002 JÖNKÖPING
Tel. +46 36 395771
Fax. +46 36 162020
info@trailax.com

Switzerland

Willy Erny AG

Fahrzeugtechnik
Alte Frauenfelderstraße 9
8542 Wiesendangen
Tel. +41 52 337 2121
Fax. +41 52 337 3530
info@erny.ch

Turkey

Intermobil Otomotiv Mümessilik

Ve Tic. A.S.
Akin Plaza
Halide Edip Adivar Mah
Ciftecevizler Deresi Sk. No 2 Kat 2
34382 Sisli – Istanbul
Tel. +90 212 320 8114
Fax. +90 212 314 2001
intermobil@intermobil.com.tr

Hungary

L.V. Technik Kft.

Kullai köz 52.
H-6000 Kecskemét
Tel. +36 76 493507
Fax +36 76 505783
lvtkft@axelero.hu

United Kingdom

IMS Limited

Gelders Hall Road
LE12 9NH Shepshed, Leics
Tel. +44 1509 600 185
Fax. +44 1509 600 235
ims@imslimited.co.uk

We are always there for you

Emergency +49 6095 301-247

Service +49 6095 301-602

Operator +49 6095 301-0

Fax +49 6095 301-259

service@safholland.de

www.safholland.com