

ABOUT FIFTH WHEELS

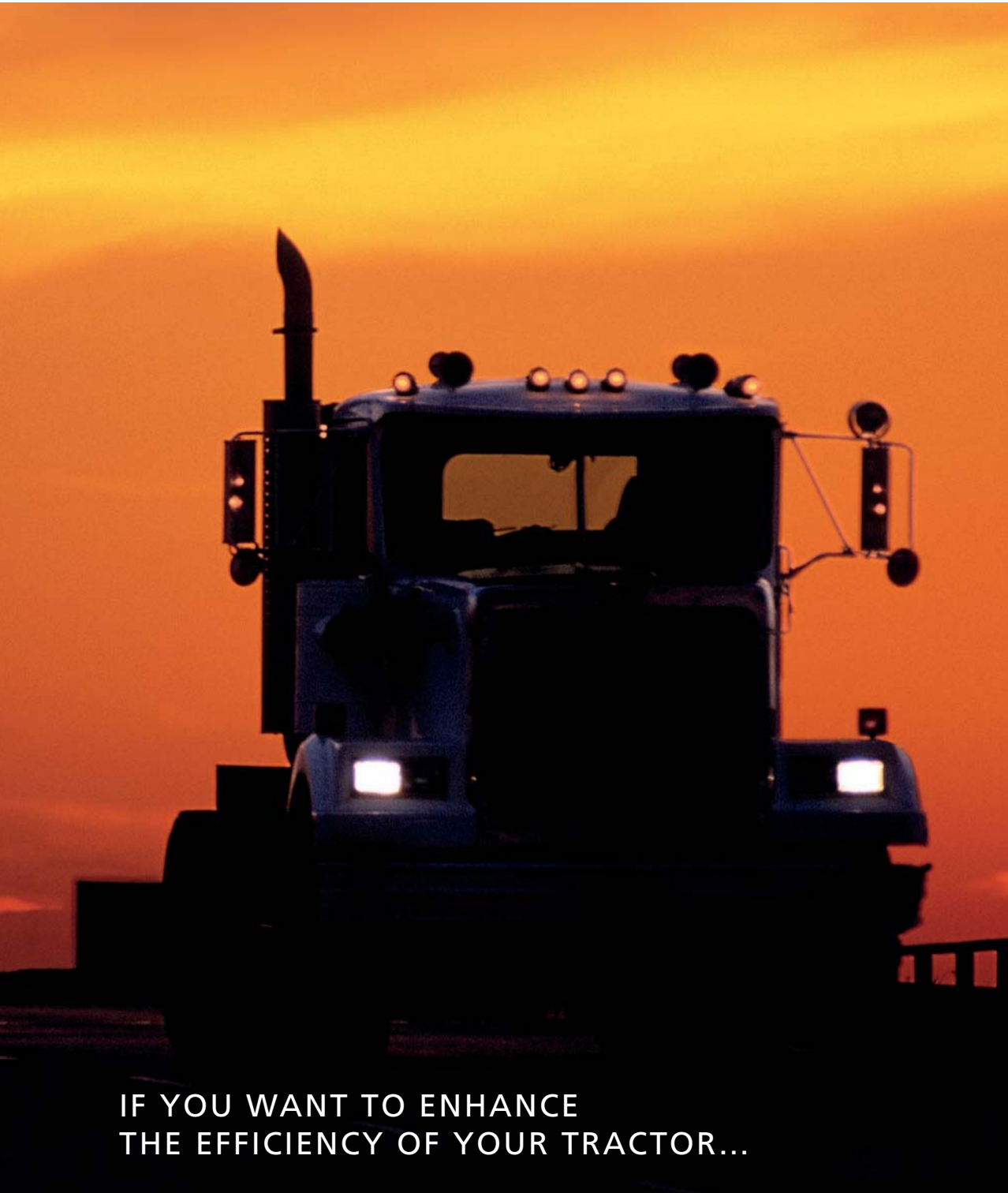

IF YOU WANT TO ENHANCE
THE EFFICIENCY OF YOUR TRACTOR...

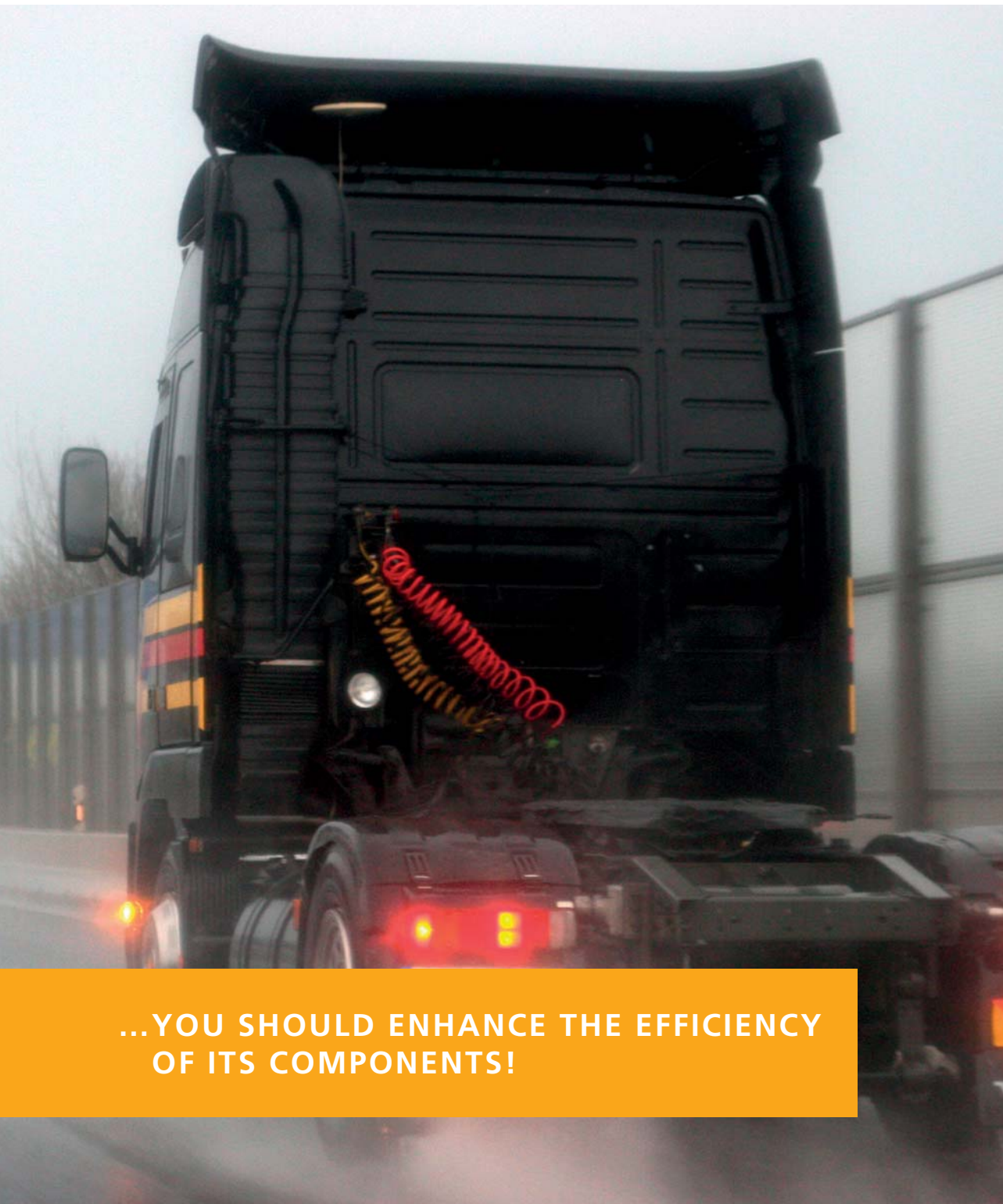

**...YOU SHOULD ENHANCE THE EFFICIENCY
OF ITS COMPONENTS!**

TWO STRONG BRANDS WITH A RICH TRADITION – AND ONE JOINT PROMISE TO YOU!

Dear business partner,

SAF-HOLLAND is the result of a very wise decision: In 2006, the former Otto Sauer Achsenfabrik SAF and the North American original equipment manufacturer for commercial vehicles, Holland Group Inc., merged to form SAF-HOLLAND, combining their strengths to achieve a common objective:



Products made by SAF-HOLLAND should win over both vehicle manufacturers and their customers, fleets and haulage companies all over the world, with outstanding product features – and live up to this claim with quality, efficiency, and service to meet the every day needs of the transport industry. This can only be achieved with the best performance, special know-how, and the dedicated teamwork of qualified partners committed to long-term success.



For this reason, SAF-HOLLAND acquired all capital shares in Georg Fischer Verkehrstechnik GmbH in Singen in 2008, setting the course for the future in another key area:



I hope you will enjoy reading the following pages, and it will please me if they help to provide you with a small glimpse into our core business. – **HOLLAND fifth wheels for practically any transport task.**

Yours sincerely,
SAF-HOLLAND Verkehrstechnik GmbH

The merger of the successful HOLLAND tradition as one of the leading brands for fifth wheels in North America with the outstanding quality of the GF foundry experts widely recognized throughout Europe and beyond.

First and foremost, we want you our customers to benefit from this: by maintaining the outstanding GF quality without compromise, by systematically incorporating future-oriented HOLLAND innovations, and with a considerably more powerful service organization that can ensure the worldwide supply of original parts. That is what we at SAF-HOLLAND Verkehrstechnik want to offer you, and we want to prove this with high-quality components and systems for trucks and trailers.



A handwritten signature in blue ink, appearing to read "Svend Koch".

Svend Koch
CEO

WHAT DOES IT DO?

In conjunction with the king pin fitted to the trailer its main function is to connect the truck (tractor unit) with the semi-trailer

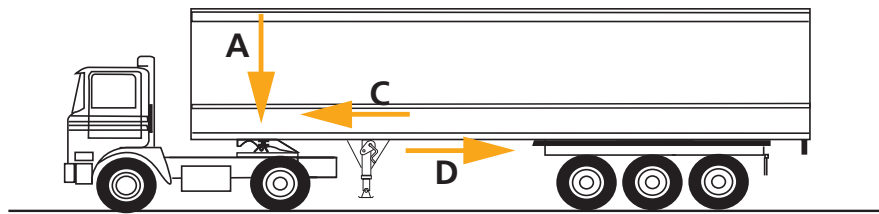

In doing so it must:

Support the weight of the trailer imposed on it **(A)**

Allow the trailer to articulate (trailer pivots relative to tractor on inclines) **(B)**

Resist the forces of:

the trailer pushing forward e.g. under braking **(C)**

the trailer "pulling back" on it e.g. starting off / accelerating **(D)**

the trailer trying to lift off e.g. when cornering due to roll **(E)**

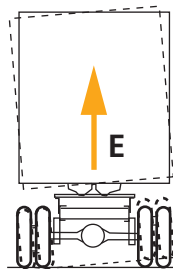
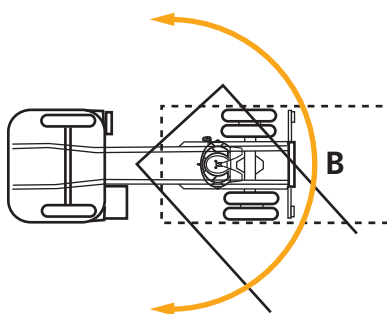

Large flat surface spreads load, supports weight and allows rotation of trailer through contact with trailer skidplate **(A)** and **(B)**

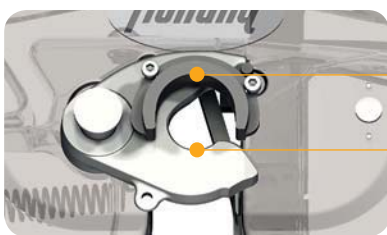

Wear Ring Contact Area Resists "Push" **(C)**

Coupler Jaw Contact Area Resists "Pull" **(D)**



To allow free and easy rotation and reduce wear lubrication is required on the top surface. This is normally grease, note the grease grooves in the top plate to help to retain and distribute the grease

King Pin

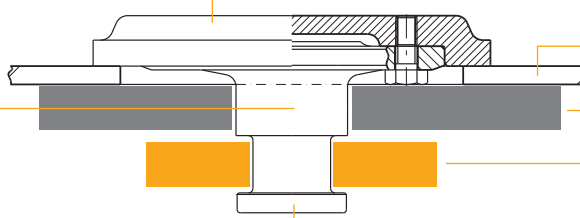

King Pin Mounting Plate

Trailer Skidplate

Fifth Wheel Top Plate

Fifth Wheel Locks Around king Pin

Flange On King Pin Resists "Lift" **(E)**

FIFTH WHEEL RATINGS AND CAPACITIES

All Fifth Wheel couplings will have ratings and capacities which are normally given as:

Vertical (or Imposed) Load acting directly on the fifth wheel through the trailer skidplate. There is no vertical load applied through the king pin.

D-value which is defined as the theoretical reference force for the horizontal force between the towing vehicle and trailer.

Gross Combination Weight (GCW) is the total weight of the tractor unit, trailer and load added together – used only in certain countries as reference.

The longitudinal force exerted between the fifth wheel locks and the king pin. For this reason king pins also have a D-value rating.

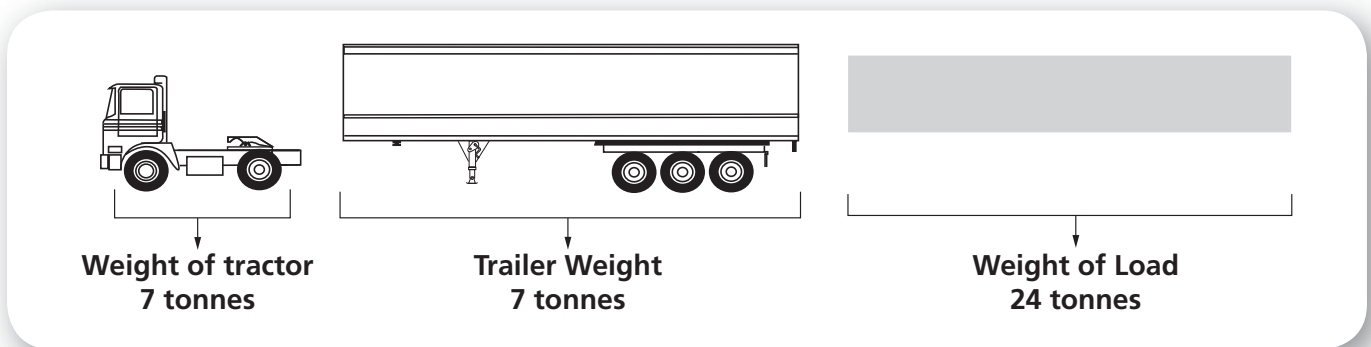

With the trailer loaded and supported on its landing legs the load (weight) is distributed between the axle-bogie and the landing legs.

When the trailer is coupled to the tractor unit the load (weight) is distributed between the axles and the fifth wheel.

The weight distribution is different because of the relative positions of the landing legs and king pin.

*The tractor unit weight now includes the 9 tonnes vertical load.

D-value – a calculation of the forces between the fifth wheel and king pin when pulling the trailer which are higher during acceleration and braking.

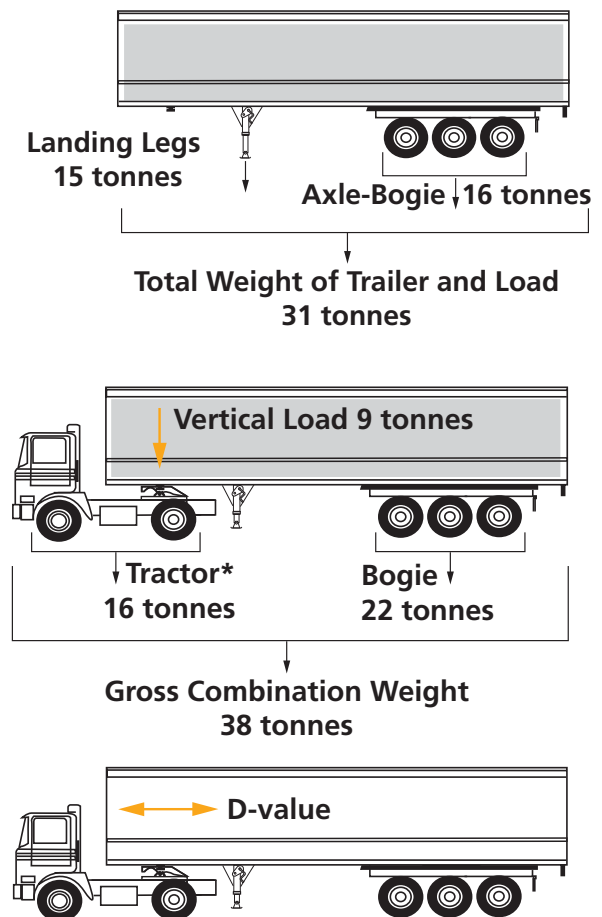

FIFTH WHEEL RATINGS AND CAPACITIES

To be correct for the application a fifth wheel must have the appropriate Vertical Load and D-value.

**Vertical Load imposed by fully loaded trailer must be at or below fifth wheel rating.
D-value of fully laden combination must be at or below fifth wheel rating.**

It is not possible to balance one figure against another.

Weight distribution for a typical heavy duty combination



Weight of tractor
9 tonnes



Total Weight of Trailer and Load
71 tonnes

*The tractor unit weight now includes the 21 tonnes vertical load

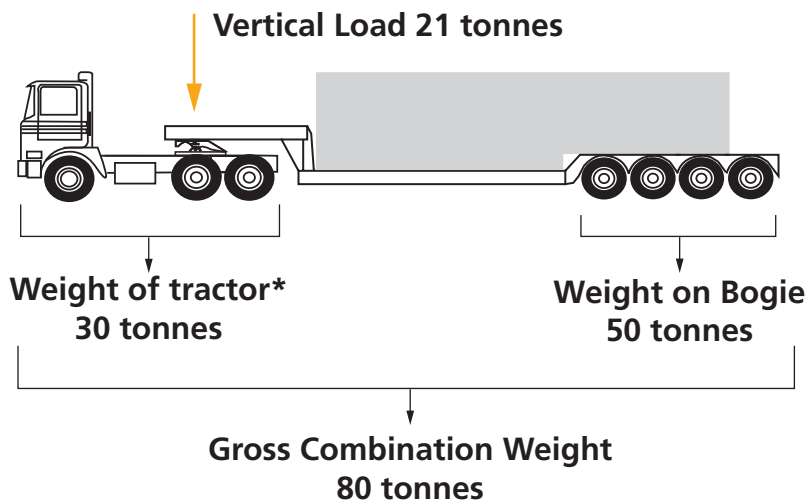

Notes specific to Heavy Duty Fifth Wheels:

80 tonnes GCW is the maximum GCW at which a 2" king pin should be used, generally the D-value limitation will take care of this (see above example), however, we should always work to this limitation – **max. GCW on a 2" king pin is 80 tonnes** – even if the D-value calculation would allow a higher GCW.

D-VALUE CALCULATION

General Notes

All fifth wheels and king pins, tested and approved under EC 94/20 and ECE-R55 regulations are given a D-value rating as an indication of the maximum horizontal force permitted between the towing vehicle and trailer.

In order to confirm the suitability of a particular fifth wheel or king pin for a given tractor/trailer combination it is necessary to carry out a D-value calculation.

Formula

The D-value formula for a tractor and semi-trailer combination is as follows:

$$D = g \times \frac{0.6 \times T \times R}{T + R - U} \text{ (kN)}$$

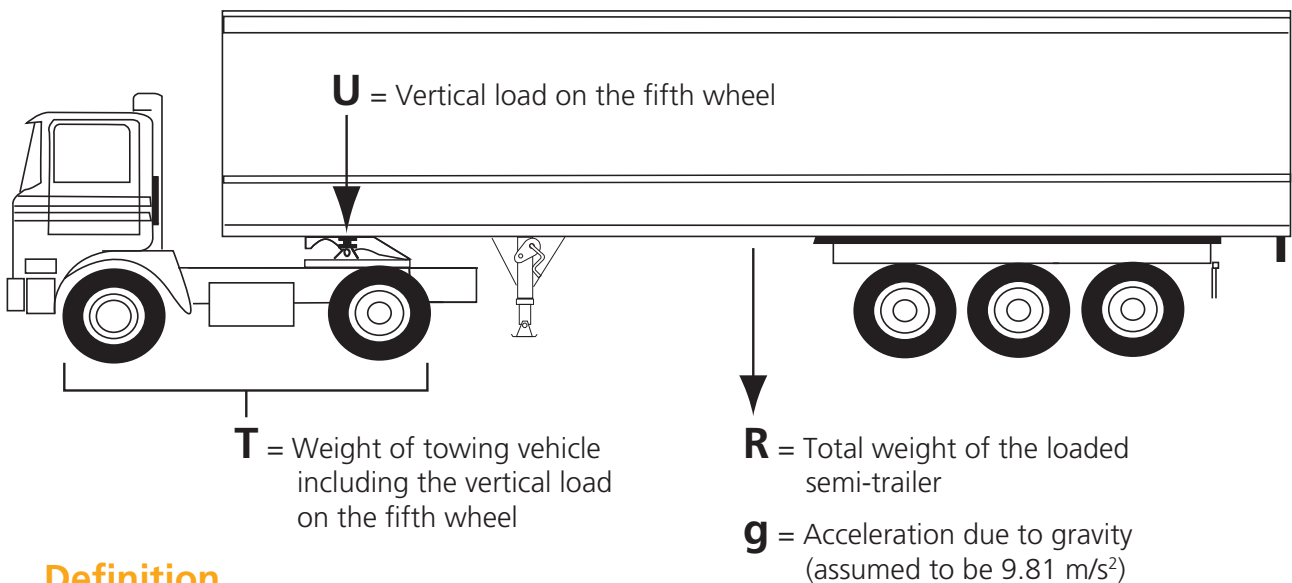

Definition

The „D-value“ is defined as the theoretical reference force for the horizontal force between towing vehicle and trailer.

The D-value is taken as the basis for horizontal loads in the dynamic tests for all automatic coupling devices between a towing vehicle and trailer.

Example Calculation

T = 17 (Tractor weight 7 t plus vertical load 10 t), **g = 9.81**

R = 33 (10 t imposed on fifth wheel and 23 t on rear bogie), **U = 10**

$$D = 9.81 \times \frac{0.6 \times 17 \times 33}{17 + 33 - 10} \text{ (kN)}$$

D-Value = 82.55 kN

THE EFFECT OF GRADIENTS

On a level road

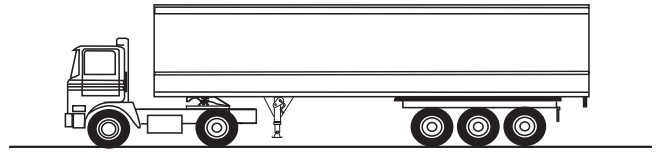

Starting to go uphill

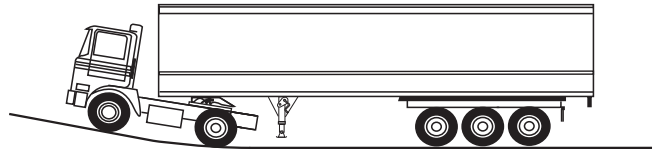

Fifth Wheel articulates (or oscillates) forward

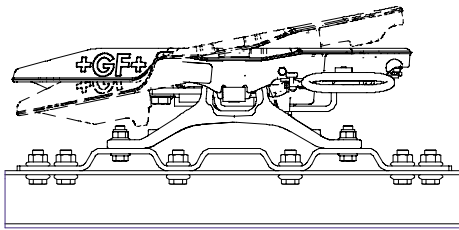

There must be a minimum of 6° free articulation when the tractor and trailer are coupled

Reduced clearance between Tractor Cab and Trailer

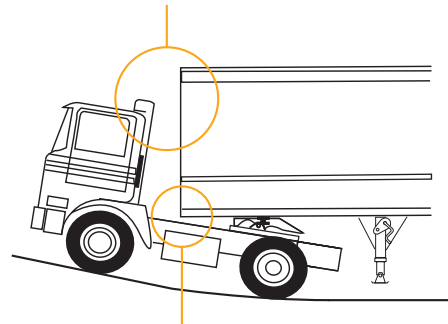

Reduced clearance between top of Chassis and Trailer

Downhill

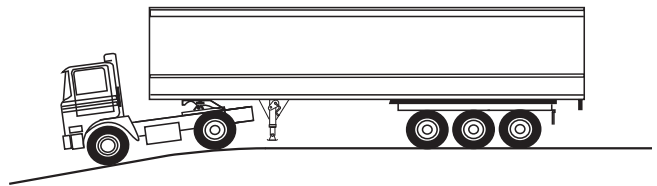

Fifth Wheel articulates (or oscillates) to the rear

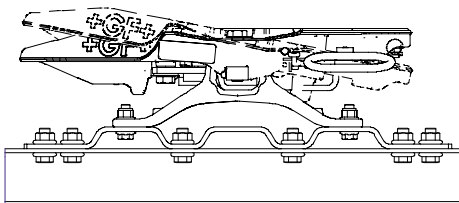

There must be a minimum of 7° free articulation when the tractor and trailer are coupled

Reduced clearance between rear of Chassis and Trailer

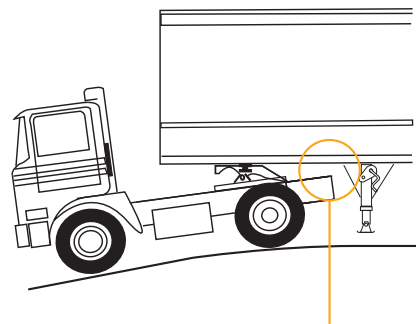

EFFECTS OF TURNING

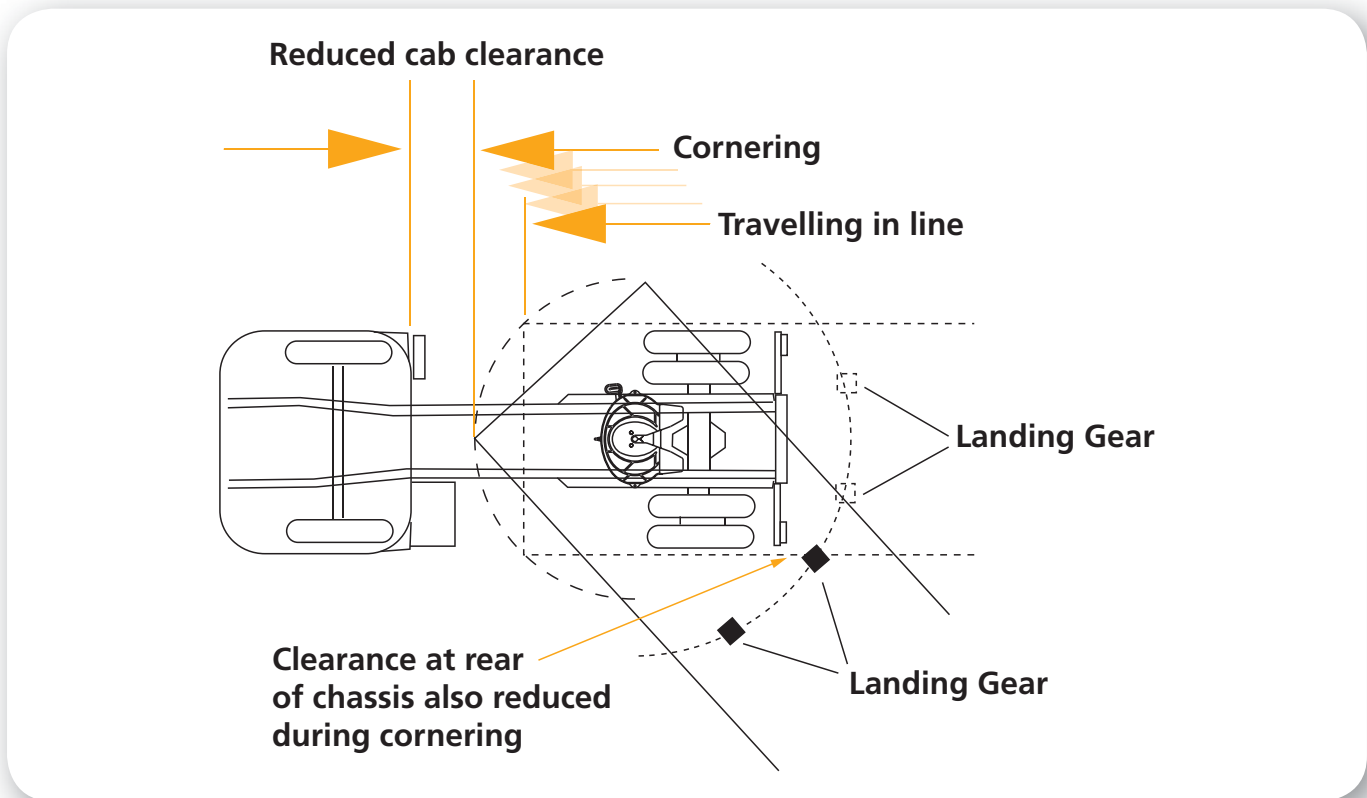

Imagine then the effect of turning and beginning to climb a hill at the same time – the combined effect of turning and climbing will reduce cab clearance even more

Fifth wheel position is therefore critical for several reasons including the overall length of the combination which is limited by legislation

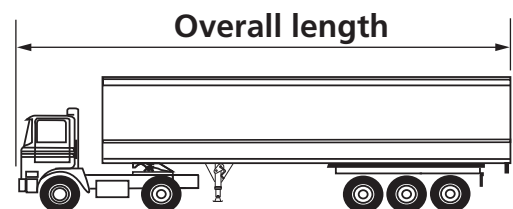

ROLL BETWEEN THE TRACTOR AND TRAILER

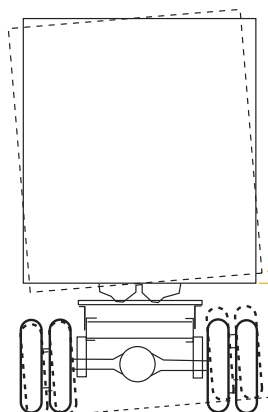

Rotation about the longitudinal axis of up to 3° of movement between the tractor and trailer is permitted.

3°

On a standard fifth wheel this occurs as a result of clearance in the fifth wheel to bracket fit, compression of the rubber bushes and also vertical movement between the king pin and locks may allow some lift of the trailer one side.

FIXED FIFTH WHEELS AND MOUNTING

Top Plate Assembly

SK-S 36.20
SK-HD 38.36
etc.

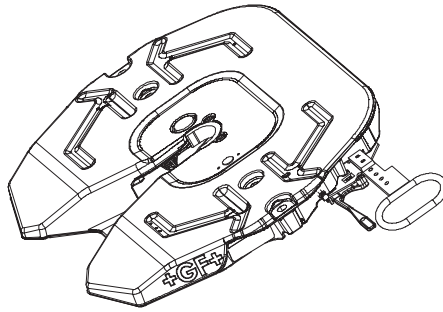

Conventional ISO Mounting (Standard DIN 6 hole feet)

Mounting Brackets (feet)

Feet bolted to mounting plate

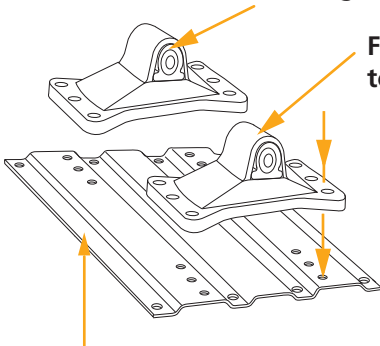

Separate Mounting Plate European style
"ripple" plate shown

Alternative ISO Direct Mounting

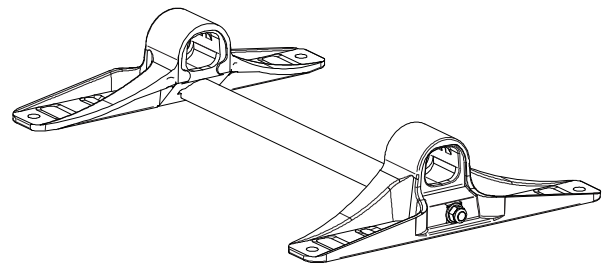

Bracket is bolted directly to L-profile
eliminating mounting plate

Truck Chassis

Mounting plate sits directly onto flitch plates and is bolted to them

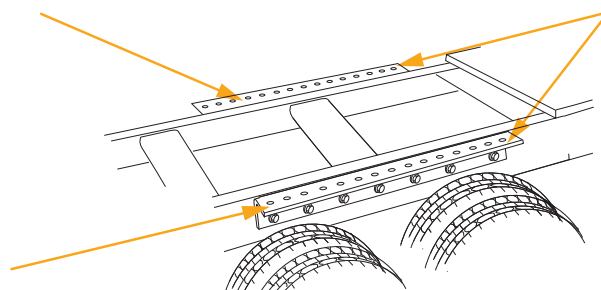

Standard "L" profile mounting angles (flitch plates) normally fitted on the truck by the truck manufacturer

It is common for the holes used for attachment of the baseplate to be pre-drilled in the mounting angles by the truck manufacturer but hole sizes and pitch centres vary with different manufacturers

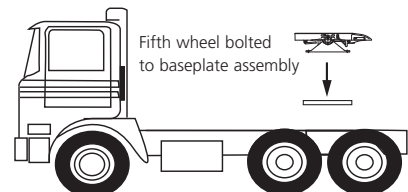

Fifth wheel bolted to baseplate assembly

SLIDING FIFTH WHEELS AND MOUNTING

Fixed Fifth Wheel

The fifth wheel can be moved forwards or backwards to accommodate different trailer lengths and/or alter weight distribution on the tractor unit

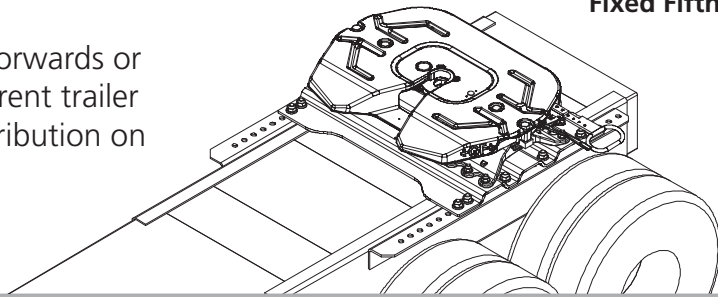

SLIDING FIFTH WHEELS – MOUNTING STYLES

Slider SK-V 20

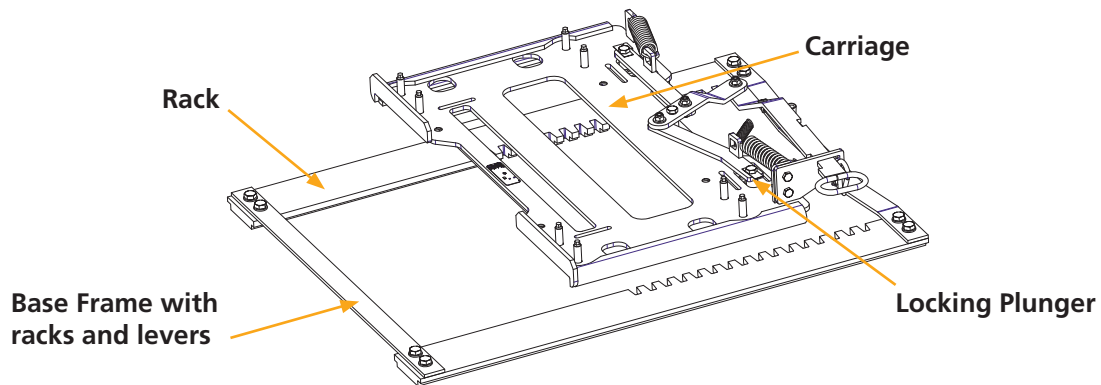

The fifth wheel SK-S 36.20 cpl. is mounted on a carriage which can be moved forward and backward along a base frame. The carriage is locked in position by plungers which lock into of the racks of the base frame.

Slider Mounted to Chassis Angles

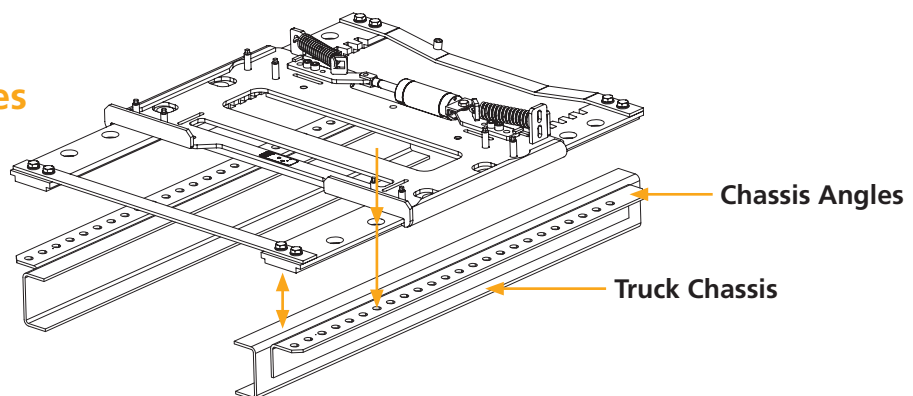

Our standard slider for normal roadgoing operations, rated up to 44 tonnes GCW and 18 tonnes vertical load.

The base frame racks are predrilled with holes so that the slider can be bolted directly to the manufacturers mounting angles without the need for a separate subframe.

FIXED FIFTH WHEELS – HEIGHT

Conventional ISO Mounting

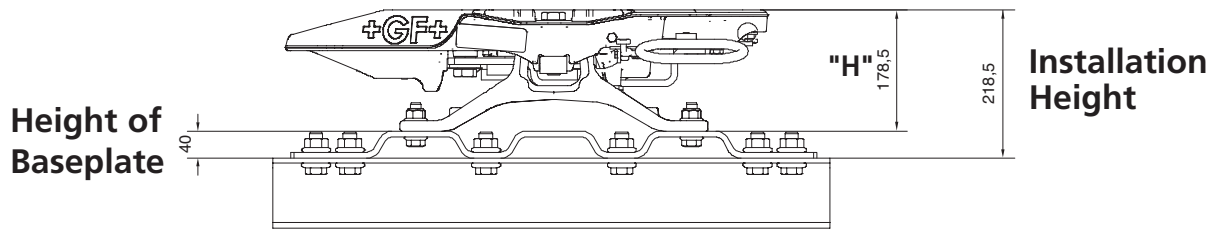

The fifth wheel height is from the bottom of the mounting bracket to the top surface of the fifth wheel. It does not include the height of the baseplate which needs to be added to the fifth wheel height "H" to give the installation height.

The baseplate/mounting plate height will vary according to the type of mounting.

The lowest will be a simple flat plate (usually 12 mm min.) a european style ripple plate is normally 22 mm or 40 mm.

Direct Mounting

As there is no separate baseplate with a direct-mount installation the fifth wheel height "H" is also the installation height.

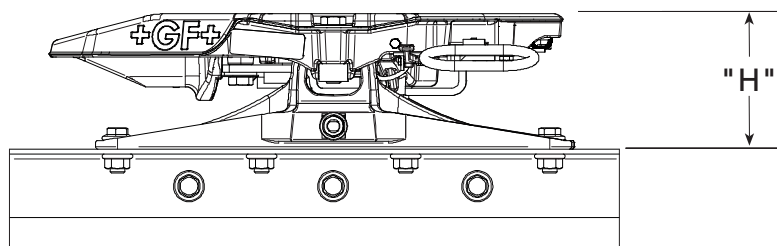

SLIDING FIFTH WHEELS – HEIGHT

For the standard ILS slider the slider height "H" is also the installation height.

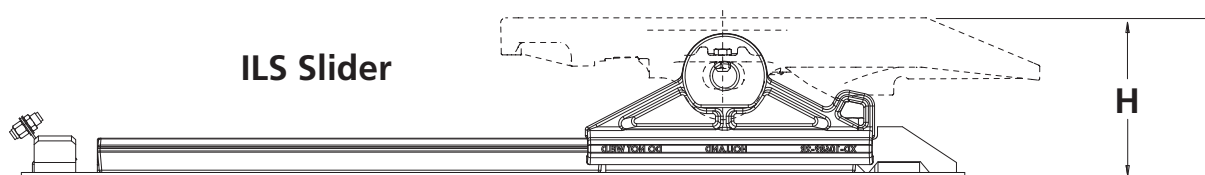

MOUNTING ANGLES/FLITCH PLATES

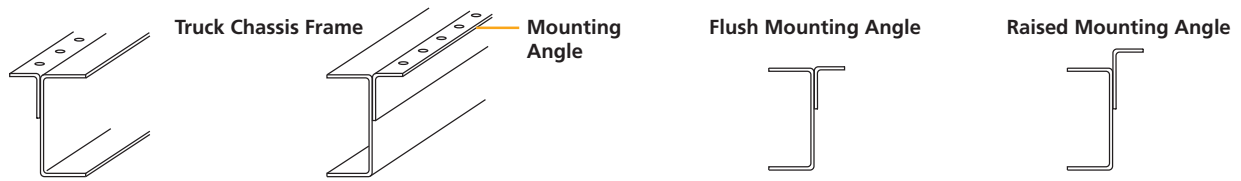

On most vehicles mounting angles are referred to as being "flush" although they are not actually flush with the top of the chassis but actually 3 or 4 mm above the chassis. Some vehicles, usually for heavy duty application, have a mounting angle which is raised by up to 60 mm. Installation height is actually from the top of the mounting angle to the top of the fifth wheel as the baseplate or slider normally sits on top of the mounting angle.

"FIFTH WHEEL HEIGHT" AND LEAD ON RAMPS

Some customers will ask for a fifth wheel to give a "fifth wheel height" of (for example) 1250 mm. They are talking about the height of the fifth wheel from the ground when installed on the truck. The fifth wheel height will be the chassis height "CH" plus the installation height e.g. a SK-S 36.20 D installed on a tractor with a chassis height of 1060 mm will give the 1250 mm fifth wheel height.

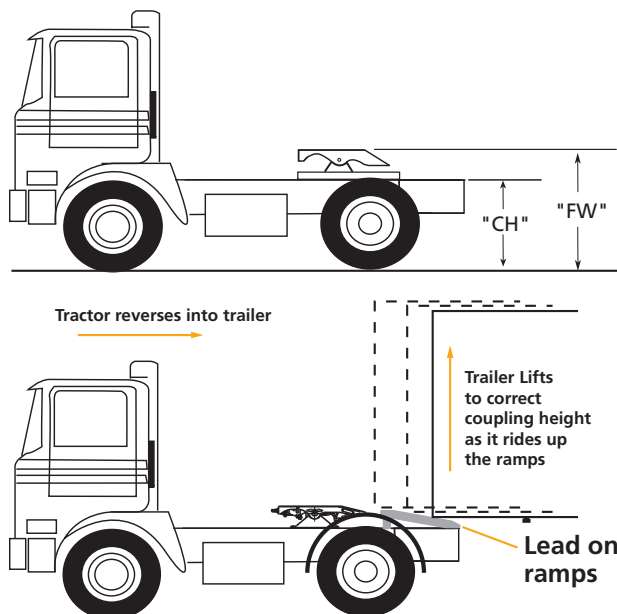

WARNING: Chassis height (and fifth wheel height) can be given as laden or unladen always insist on working to the unladen figures.

Lead on Ramps are required by certain (UK) customers. If the trailer is too low during coupling it may hit the rear wings or other components causing damage to the vehicle. With ramps fitted the trailer will ride up the ramps avoiding damage to the wings etc.

NOTE: The height of the ramps is critical, it must be high enough to protect the wings but low enough to allow the correct angle of articulation without the underside of the trailer skidplate hitting the top of the ramps. Sometimes this can be a compromise and where the fifth wheel installation height is low it may not be possible and/or practical to fit ramps.

DEVELOPMENTS IN FIFTH WHEEL TECHNOLOGY

Low Lube (or Low Maintenance) Fifth Wheels



Fifth Wheels developed to reduce maintenance costs, replaceable lube plates on the top surface eliminate the need for grease so reducing servicing time, costs and vehicle downtime. The lock system and components do still require grease/lubrication.

Innovative Fifth Wheel of Forged Aluminium



A further development of the above where lock components, etc. are manufactured with special coatings/treatments eliminating the need for lubrication during the life of the fifth wheel. These fifth wheels can be used in a fleet where other fifth wheels/trailers are still using a greased system – the grease will not harm the NoLube components.

Terminal Fifth Wheels e.g. FW 3510-TR





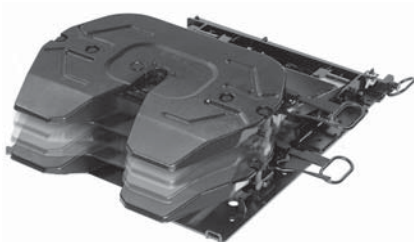

Developed specifically for use on terminal tractors cast in a specially selected extra high grade steel and tailor made for increased loads and durability in this extremely demanding environment. Available with optional manual secondary lock for movement of trailers on the public highway.

Dual Height Fifth Wheel SK-S 36.20 H





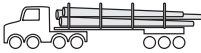

A height adjustable fifth wheel which can be used in lowered or raised position. It is designed for volume transportation with 2-axle low liner trucks and mega trailers. The dual height fifth wheel allows in uncoupling condition to elevate the lifting device by air so that trailers with different coupling heights can be coupled with the same truck. The elevating fifth wheel is available pre-drilled to fit all european vehicles.

FIFTH WHEEL SELECTION GUIDE



					
75 t _					45-75 t
45 t _					
36 t _				36 t	
20 t _			20 t		
15 t _		15 t			
6 t _	6 t				
0 t _					
Application	<ul style="list-style-type: none"> · light distribution traffic · mid-sized carrier class · light trucks up to 7.5 tonnes 	<ul style="list-style-type: none"> · flexible distribution traffic · volume carrier · two-axle tractor 	<ul style="list-style-type: none"> · standard long-distance haulage · silo, tank, and volume transport · two- and three-axle tractors 	<ul style="list-style-type: none"> · HGV traffic · traffic in difficult terrain 	<ul style="list-style-type: none"> · Extremely heavy goods transports and special transports

Fifth wheel

GC 6	SK-S 36.20 H	FWAL-E	SK-HD 38.36	FW0100
				
Imposed load 6.000 kg Overall height 120 mm D-value 49 kN	Imposed load 15.000 kg Overall heights 167, 267, 317, 367 mm D-value 110 kN	Imposed load 20.000 kg Overall height 167, 197, 219 mm D-value 50 kN	Imposed load 36.000 kg Overall heights 150, 190 mm Lock size 2"/3,5" D-value 162/260 kN	Imposed load 45.000 kg Overall heights 230, 270 mm D-value 165/170 kN (2") 240 kN (3,5")

Specifications

The load data specified only applies to operation on paved roads and to transport conditions usual in Central Europe. Please contact us regarding operating conditions which deviate from these. We reserve the right to modify dimensions or design if required. No responsibility is taken for the correctness of the details provided, these are solely intended for technical information.

SK-S 36.20	SK-HD 38.36 G	FW0165
		
Imposed load 20.000 kg Overall heights 128, 150, 185, 225, 250 mm D-value 152 kN	Fifth-wheel for off-road use with gimbal mounting Lock size 2"/3,5" Imposed load 23.000 kg (2") 36.000 kg (3,5") Overall height 290 mm D-value 162/260 kN	Imposed load 74.000 kg Overall heights 230, 270 mm D-value 165/170 kN (2") 240 kN (3,5")

Support on demand

We are pleased if this summary is of help to you in your preliminary planning and decision-making and in choosing the optimal product for your transport tasks. Should you have any further questions with regard to this or require personal assistance, we at SAF-HOLLAND Verkehrstechnik will be available with support that is competent, reliable and committed.

FW3510

Imposed load 20.000 kg Overall heights 150, 180, 200 mm D-value 150 kN

GES 20

Imposed load 20.000 kg Overall heights 150, 185, 225, 250 mm D-value 152 kN



SAF-HOLLAND is the result of a very wise decision: In 2006, the former Otto Sauer Achsenfabrik SAF and the North American original equipment manufacturer for commercial vehicles, Holland Group Inc., merged to form SAF-HOLLAND, one of the leading global suppliers for the commercial vehicle industry.

Alongside axle and suspension systems for trailers and semi-trailers, the product range also includes kingpins and landing gear as well as fifth wheels for tractors, air suspensions, coupling products and numerous other components for buses and trucks.

Today the SAF-HOLLAND group is represented on all continents and distributes its products and services worldwide under the brand names SAF and HOLLAND as well as GF, TRILEX and NEWAY.

SAF-HOLLAND possesses its own distribution network with global service and dealer locations.

HIGH QUALITY COMPONENTS FOR THE COMMERCIAL VEHICLE INDUSTRY

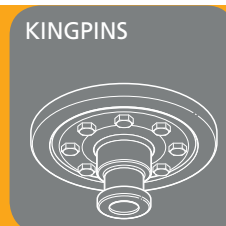

EUROPE · NORTH AMERICA · SOUTH AMERICA · AFRICA · ASIA · AUSTRALIA

SAF-HOLLAND Verkehrstechnik GmbH

Julius-Bührer-Straße 12 · 78224 Singen · Germany

Tel +49 7731 1443-0 · Fax +49 7731 1443-200 · info.vkt@safholland.com

www.safholland.com

