

Labour time allowance chart for warranty repair work

**for Fifth Wheels
Landing Gear
Kingpin
Ball Race
TRILEX**

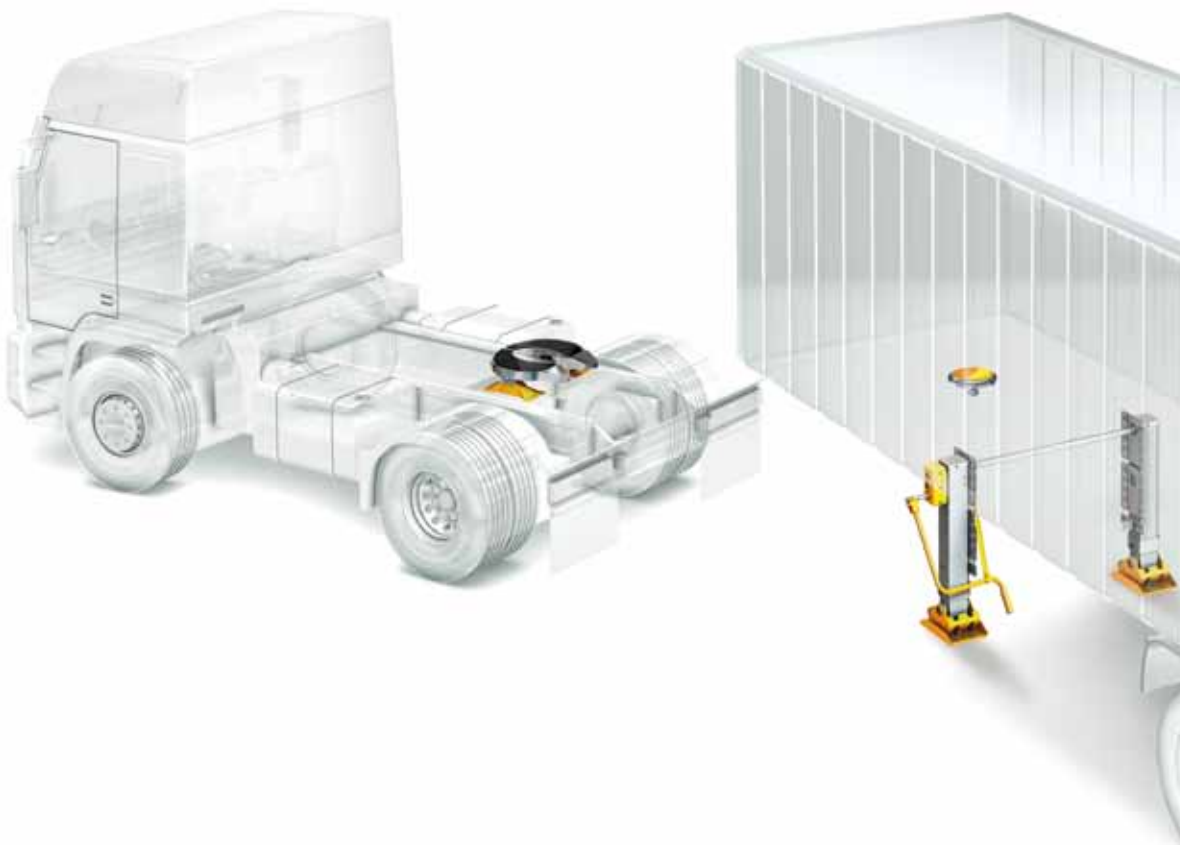

Introduction 3

Service Report..... 3

Warranty Claim Administration time (handling costs)..... 3

 Warranty Labour Schedule for Fifth Wheels 4

 Warranty Labour Schedule for Slider..... 5

 Warranty Labour Schedule for Recoss..... 5

 Warranty Labour Schedule for Landing gear 6

 Warranty Labour Schedule for Kingpin 6

 Warranty Labour Schedule for Ball Race 7

 Warranty Labour Schedule for TRILEX..... 7

Vehicle preparation time, once-only 15 minutes per vehicle including

- Vehicle brought into work place
- Vehicle secured in accordance with standard safety working practices
- Inspection of the components for re-use, clean or replace as necessary
- Tighten bolts and nuts in accordance with the SAF recommended torque setting
- Prepare any defective parts available for inspection by SAF

Procedures, which are not included in this labour time allowance catalogue, must be justified and prior authorisation given by SAF Service department before any repair work is carried out.

Service Report

In the event of damage, always first complete the SAF Service Report: available over the Internet:

www.safholland.com

SAF Service Report must be completed fully and accurately.

All labour time allowances are continuously updated according to technical demands.
The updates are available under:

www.safholland.com

We recommend SAF Original spare parts for all repairs.

Warranty Claim Administration time (handling costs)

No.		Minutes
S10001	Administration time allowance for handling the warranty claim, processing and the claim acceptance for SAF Service-Partner / Competence Partner and Service 24	45
S10002	Administration time allowance for handling the warranty claim, processing and the claim acceptance without inspection of claimed warranty parts for SAF Subsidiary / National agent	15
S10003	Administration time allowance for handling the warranty claim, processing and the claim acceptance with inspection of, and responsibility for, claimed warranty parts for SAF Subsidiary / National agent	30
S10010	Additional (must be separately quoted in the invoice)	
S10011	Labour time for road side assistance	According expenses
S10012	Travelling kilometres for road side assistance	According expenses

Fifth Wheels

No.		Minutes
S11101	Vehicle preparation time, once-only per vehicle including <ul style="list-style-type: none"> • Vehicle brought into work place • Vehicle secured in accordance with standard safety working practices 	15
S81000	Top Plate - Replacement - models F. outside pin retention - Models F17E, FW17EK, FW3510, FW3110, FW0E70	15
S81011	Top Plate - Replacement - models SK.. outside pin retention -Model SK-S 36.20, complete family	25
S81001	Bracket replacement: stationary (ISO) <ul style="list-style-type: none"> • removal of top plate 	75
S81012	Bracket replacement : Model SK-S 36.20, complete family <ul style="list-style-type: none"> • removal of top plate 	85
S81002	Bracket replacement: weightsaver mount <ul style="list-style-type: none"> • removal of top plate 	60
S81003	Top plate rebuilt: Models F17E, FW17EK <ul style="list-style-type: none"> • removal of top plate 	75
S81004	Top plate rebuilt: Models FW3510, FW3110 <ul style="list-style-type: none"> • removal of top plate 	105
S81005	Top plate rebuilt: Models FW0E70 <ul style="list-style-type: none"> • removal of top plate 	150
S81013	Top plate rebuilt: Models SK-HD 38.36 <ul style="list-style-type: none"> • removal of top plate 	60
S81006	Lock replacement: Models F17E, FW17EK <ul style="list-style-type: none"> • removal of top plate 	30
S81007	Lock replacement: Models FW3510, FW3110 <ul style="list-style-type: none"> • removal of top plate 	45
S81014	Lock replacement: Models SK-S 36.20, complete family <ul style="list-style-type: none"> • removal of top plate 	35
S81008	Lock replacement: Model FW0E70 <ul style="list-style-type: none"> • removal of top plate 	75
S81015	Lock replacement: Model SK-HD 38.36 <ul style="list-style-type: none"> • without removal of top plate 	30
S81009	Lube plate replacement Models FW17EK, FW3110, SK-S 36.20 W (complete family)	20
S81010	Air cylinder replacement Models FW3510-TR, FW3510-88	15

Slider

No.		Minutes
S11101	Vehicle preparation time, once-only per vehicle including <ul style="list-style-type: none"> • Vehicle brought into work place • vehicle secured in accordance with standard safety working practices 	15
S84000	replace Model SK-V 36 <ul style="list-style-type: none"> • removal of top plate 	120
S84002	replace Model SK-V 20 <ul style="list-style-type: none"> • removal of top plate 	90
S84001	Bracket replacement: slide (ILS), Model SK-V 20 <ul style="list-style-type: none"> • removal of top plate 	45
S84003	Bracket replacement: slide (ILS), Model SK-V 36 <ul style="list-style-type: none"> • removal of top plate 	60

Recoss

No.		Minutes
S11101	Vehicle preparation time, once-only per vehicle including <ul style="list-style-type: none"> • Vehicle brought into work place • vehicle secured in accordance with standard safety working practices 	15
S87000	Recoss-Control box 662129400 replace	30
S87001	Recoss-Control box 662129410 replace	45
S87002	Sensor system complete replacement	90

Landing gear

No.		Minutes
S11101	Vehicle preparation time, once-only per vehicle including <ul style="list-style-type: none"> • Vehicle brought into work place • vehicle secured in accordance with standard safety working practices 	15
S82000	complete replacement	120
S82001	Replacement of 1 leg	60

Kingpin

No.		Minutes
S11101	Vehicle preparation time, once-only per vehicle including <ul style="list-style-type: none"> • Vehicle brought into work place • vehicle secured in accordance with standard safety working practices 	15
S83000	replace	20

Ball race

No.		Minutes
S11101	Vehicle preparation time, once-only per vehicle including <ul style="list-style-type: none"> • Vehicle brought into work place • vehicle secured in accordance with standard safety working practices 	15
S85000	without fitte centraol lube system replace	90

TRILEX

No.		Minutes
S11101	Vehicle preparation time, once-only per vehicle including <ul style="list-style-type: none"> • Vehicle brought into work place • vehicle secured in accordance with standard safety working practices 	15
S86000	Front wheel spider replace	40
S86001	Back wheel spider with spacer ring replace	90
S84001	Bracket replacement: slide (ILS), Model SK-V 20	60

We are always there for you

Emergency +49 6095 301-247

Service +49 6095 301-602

Operator +49 6095 301-0

Fax +49 6095 301-259

service@safholland.de

www.safholland.com