

SAF BALL RACES

SAF BALL RACES

FOR DRAWBAR TRAILERS



SAF Ball Races for drawbar trailers

SAF-HOLLAND ball races are components for fitting onto trailers and agricultural vehicles operated on-road.



Product information

- The specifications are nominal dimensions and are subject to the tolerances at our works
- Ball races from SAF-HOLLAND are suitable for the installation on the front axle of 2- and 3-axle drawbar trailers with a max. permissible speed of 105 km/h (65mph)
- On 2-axle-trailers the specified axle loads can be exceeded by 10%
- At speeds below 30 km/h (18 mph) by 20%
- If the ball races are used in forced-steering systems, please ask the allowed load data
- All data are for the use on paved roads as usual in Western Europe
- 8 lubrication points with grease nipples
- TÜV approved

Typ S Standard	Order-No.	Typ W Low	Order-No.	Model	Max.axial load t	A mm	B mm	C mm	D mm	E mm	F mm	d mm	h mm	H mm	Weight kg
BR-S 8	662 106 100	BR-W 8	662 106 110	undrilled	8	1000	960	877	846	974	1008	18	10	90	73
BR-S 10	662 106 120	BR-W 10	662 106 130	undrilled	10	1000	960	877	846	974	1008	18	10	90	73
BR-S 10-1	662 106 140	BR-W 10-1	662 106 150	drilled	10	1100	1060	977	946	1074	1108	18	10	90	80
BR-S 12-1	662 106 160	BR-W 12-1	662 106 170	drilled	12	1100	1060	977	946	1074	1108	18	10	90	80
BR-S 13-2	662 106 180	BR-W 13-2	662 106 190	drilled	13	1200	1160	1077	1046	1174	1208	18	10	90	87

Surface coating

- The vehicle manufacturer does not need to coat
- Surface powder coated
- Colour RAL 9005

Please note: If low-maintenance ball races are recoated, the sealing lip can stick or separate partly or completely. A reverse installation is not permitted!

Single Row Ball Races – Standard Maintenance

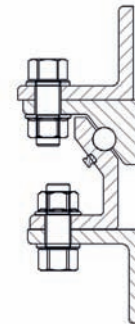
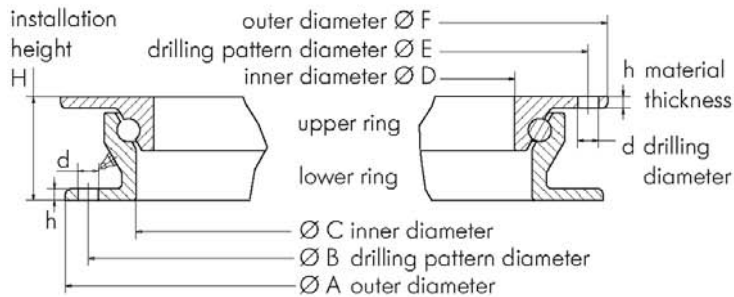

Single Row Ball Races – Low Maintenance

The low maintenance ball race series BR-W enjoy a low maintenance life cycle of up to 3 years or 300.000 km. After that period they are to be serviced in the same way as standard ball races.

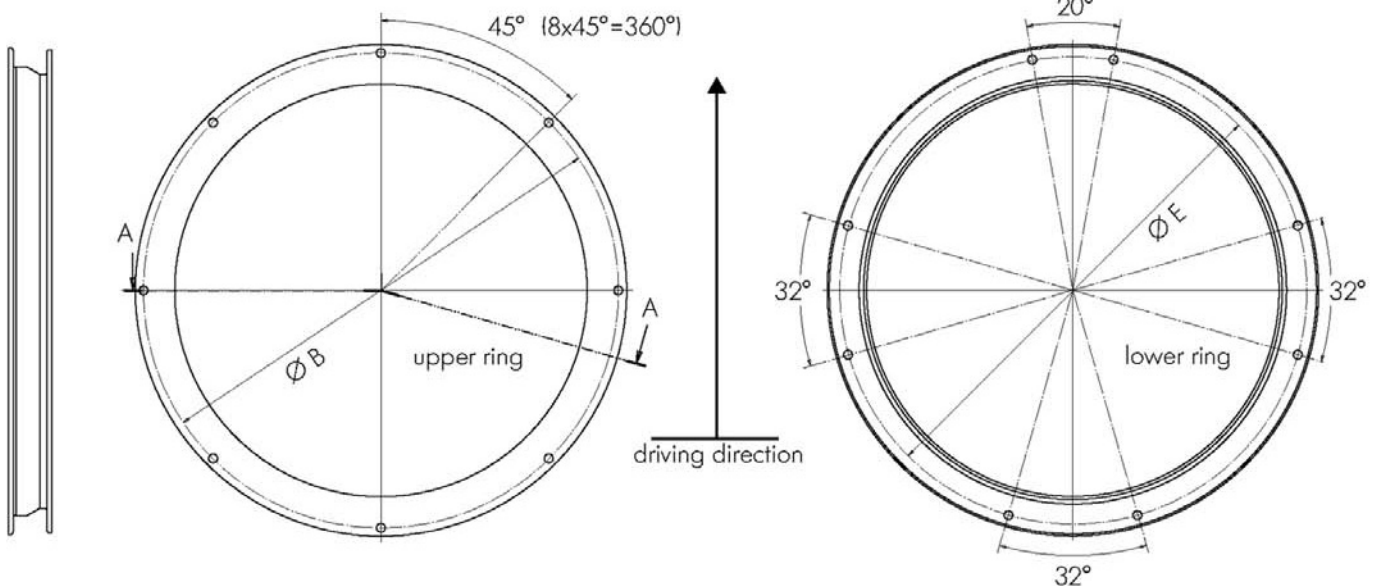
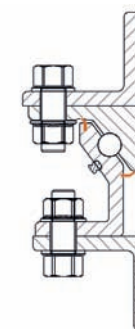
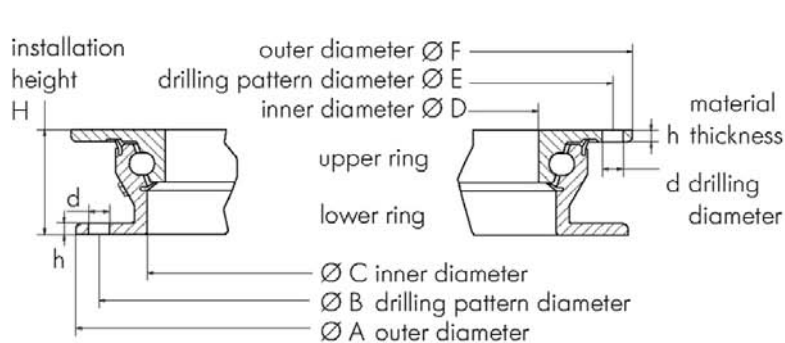

Please follow the specific trailer manufacturer instructions for the operation of the particular vehicle. Compliance with the corresponding national legislation safety standard is required.



SAF's history begins in 1881 in a village forge in Germany with the invention of a new plough. The family business soon starts building steel axles for agricultural vehicles, and under the name Otto Sauer Achsenfabrik (SAF) develops into one of the leading manufacturers of trailer axles and suspension systems in Europe.

A safety coupling between plough and horse team can be found at the beginning of Holland's history. The Safety Release Clevis Company was founded in South Dakota, USA, in 1910. After its move to Holland, Michigan, the company emerges as one of the largest supplier companies to the commercial vehicles industry under the name The Holland Hitch Company.

The merger of the two companies to form SAF-HOLLAND in 2006 creates one of the leading global suppliers of high-quality components and services for the commercial vehicle industry. Alongside axle and suspension systems for trailers and semi-trailers, the product range also includes kingpins and landing gear as well as fifth wheels for tractors, air suspensions, coupling products and numerous other components for buses and trucks.

In 2008, SAF-HOLLAND takes over Georg Fischer Verkehrstechnik, a leading supplier to the commercial vehicle industry, expanding its product range with GF fifth wheels and kingpins as well as the TRILEX wheel system and accessories for tractors, semitrailers and trailers.

Today the SAF-HOLLAND group is represented on all continents and distributes its products and services worldwide under the brand names SAF and HOLLAND as well as GF, TRILEX and NEWAY. It possesses its own distribution network with global service and dealer locations.

HIGH QUALITY COMPONENTS AND SYSTEMS FOR THE COMMERCIAL VEHICLE INDUSTRY



EUROPE · NORTH AMERICA · SOUTH AMERICA · AFRICA · ASIA · AUSTRALIA

SAF-HOLLAND GmbH

Hauptstraße 26 · 63856 Bessenbach · Germany · Tel +49 6095 301-0

www.safholland.com

