

SAF TRAILER AXLES

SAF
CHASSIS AXLE



WELCOME

SAF-HOLLAND counts among the leading global OEM suppliers of complete solutions to the commercial vehicle industry.

QUALITY COMPONENTS FOR TRACTORS

- GF and HOLLAND Fifth-Wheels
- Mounting Plates
- Mounting Kits
- Sliders
- Accessories
- NEWAY Rear Axle Suspension Systems
- TRILEX Wheel Systems

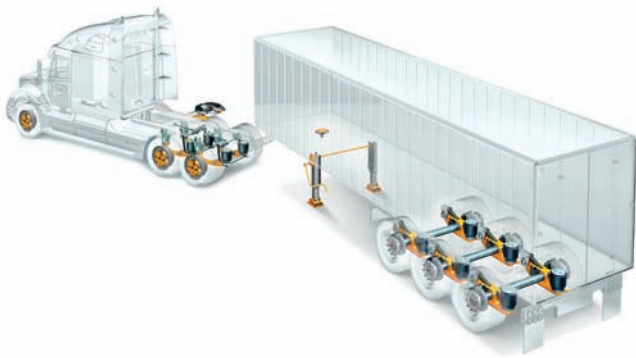

QUALITY COMPONENTS FOR SEMITRAILERS AND TRAILERS

- Integrated Suspension Systems
Product Line SAF INTRA
Product Line SAF MODUL
- SAF Individual Solutions
- SAF Landing Gear System
- SAF Kingpins

FOR ALL TRANSPORT TASKS



FOR ANY TRAILER



FOR YOUR FLEET



SAF Chassis Axle

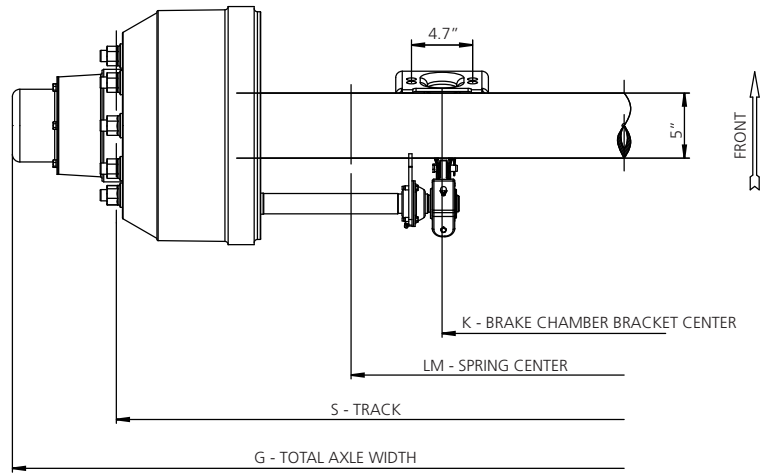

SAF Benefit

Selective longterm corrosion protection also on hub caps, fixtures and nuts

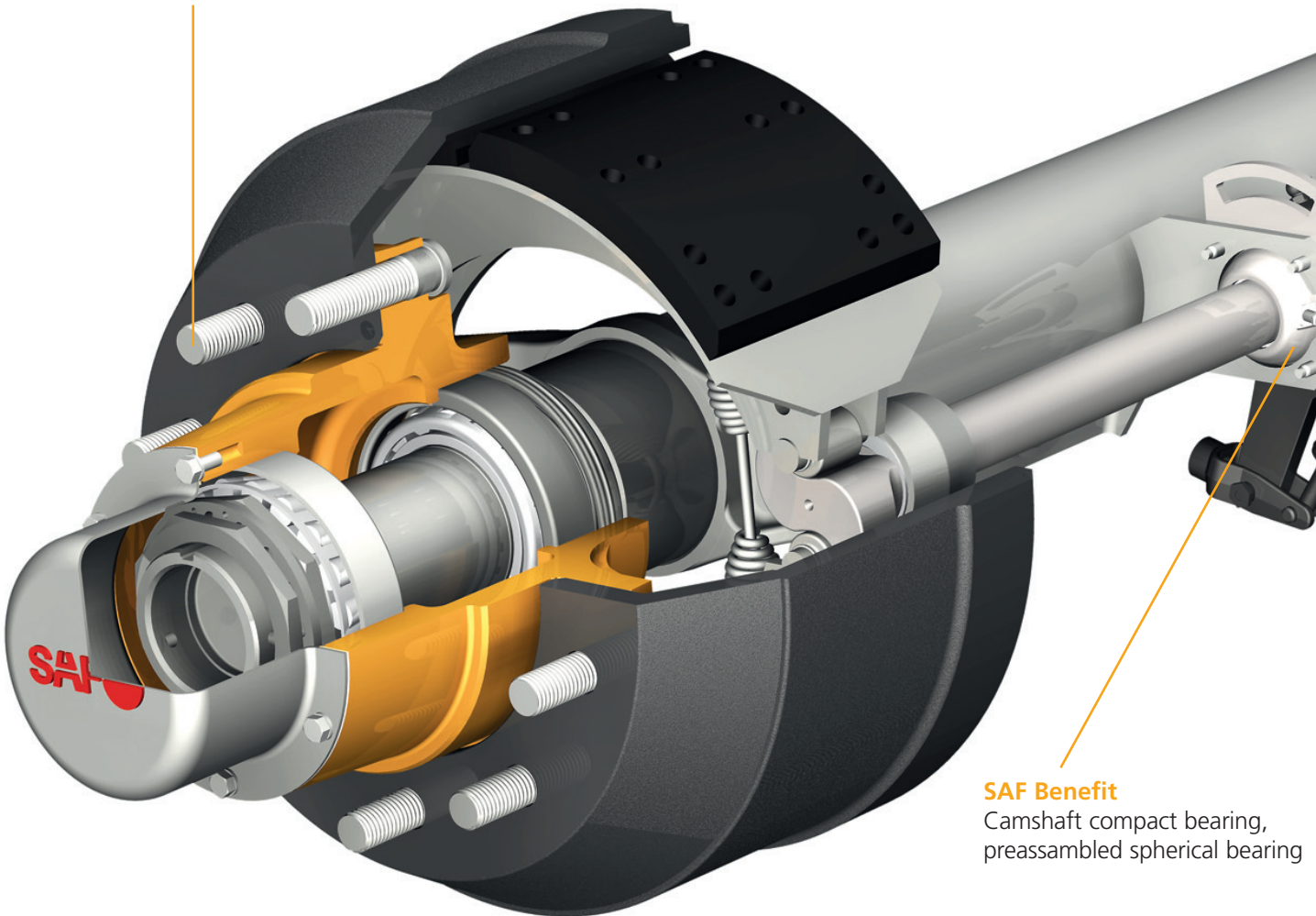

Capacity max 22,500 lbs

Axle beam: Ø 5"

Wheel fixing: 10 studs M22x1.5
bolt circle 11.25"
hub pilot 8.78"
5 spoke wheel 20"

Suitable for: Air suspension and Mechanical suspension

SAF Benefit

ABS preparation as standard

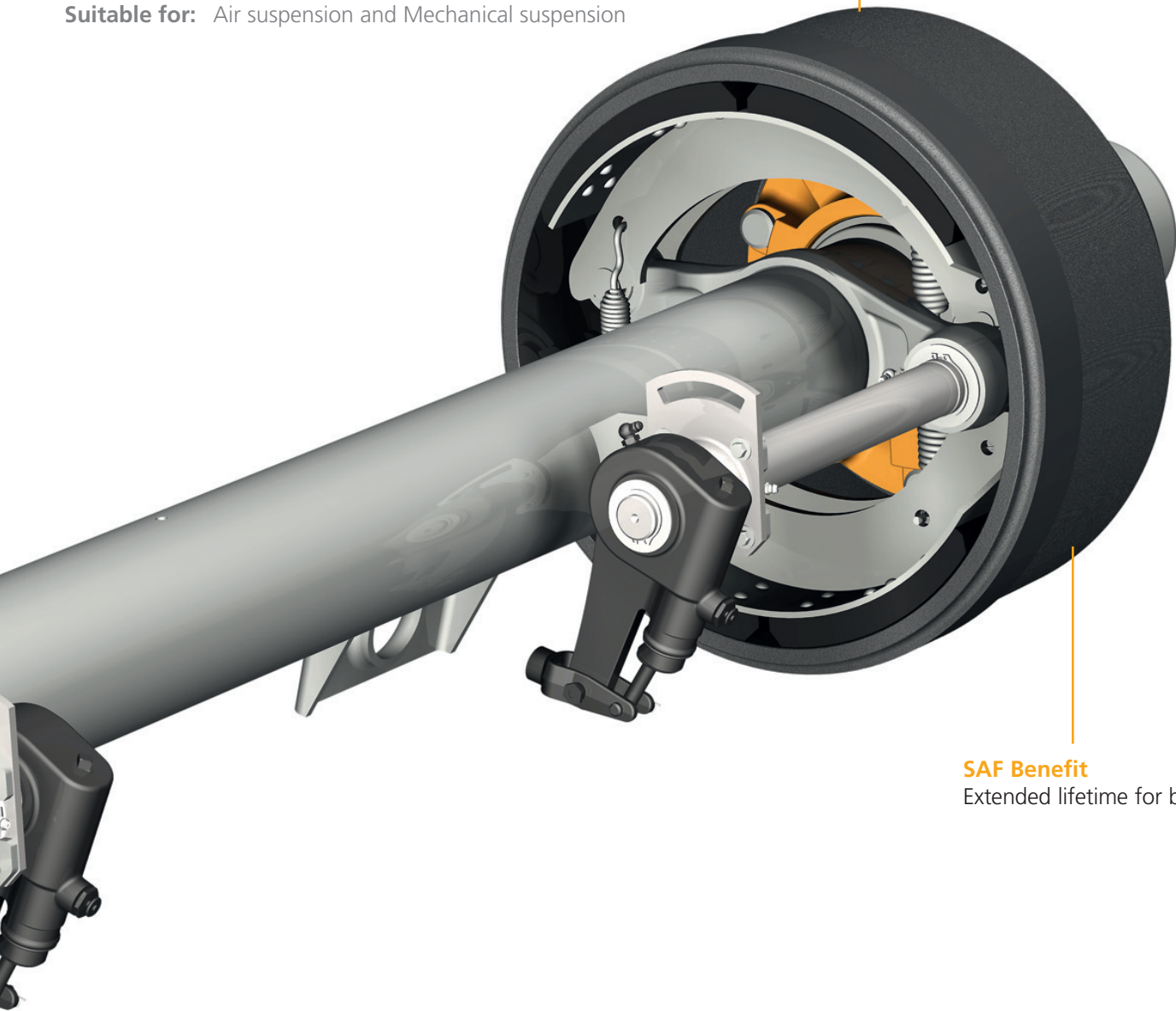

SAF Benefit

Extended lifetime for brake linings

Axle Type	Axle Load lbs	Track		Spring Center		Brake Chamber Center		Total Length		Total Weight lbs	Wheel Fixing			Brake Type inch	Bearing Type
		S	LM	K	G	Wheel Bolts	PCD inch	Rim Center inch							
Z10-16570-01 ⁷⁾	Up to 22,500 pounds depending on Track and Spring Center	71.5	36	22	88	660	10/M22x1.5 ISO	11.25	8.78	16.5x7.0	HM212049 HM212011 HM218210				
		77.5	42	28	94	670									
Z10-16570-02 ⁸⁾		71.5	36	22	88	675									
		77.5	42	28	94	686									

1) Other tracks upon request
2) Automatic slack adjusters as standard
3) ABS ready
4) Other PCD upon request

5) Five-spoke wheel end optional
6) Braked beam assembly optional
7) Taper spindle
8) Parallel spindle



SAF's history begins in 1881 in a village forge in Germany with the invention of a new plough. The family business soon starts building steel axles for agricultural vehicles, and under the name Otto Sauer Achsenfabrik (SAF) develops into one of the leading manufacturers of trailer axles and suspension systems in Europe.

A safety coupling between plough and horse team can be found at the beginning of Holland's history. The Safety Release Clevis Company was founded in South Dakota, USA, in 1910. After its move to Holland, Michigan, the company emerges as one of the largest supplier companies to the commercial vehicles industry under the name The Holland Hitch Company.

The merger of the two companies to form SAF-HOLLAND in 2006 creates one of the leading global suppliers of high-quality components and services for the commercial vehicle industry. Alongside axle and suspension systems for trailers and semi-trailers, the product range also includes kingpins and landing gear as well as fifth wheels for tractors, air suspensions, coupling products and numerous other components for buses and trucks.

In 2008, SAF-HOLLAND takes over Georg Fischer Verkehrstechnik, a leading supplier to the commercial vehicle industry, expanding its product range with GF fifth wheels and kingpins as well as the TRILEX wheel system and accessories for tractors, semitrailers and trailers.

Today the SAF-HOLLAND group is represented on all continents and distributes its products and services worldwide under the brand names SAF and HOLLAND as well as GF, TRILEX and NEWAY. It possesses its own distribution network with global service and dealer locations.

HIGH QUALITY COMPONENTS FOR THE COMMERCIAL VEHICLE INDUSTRY

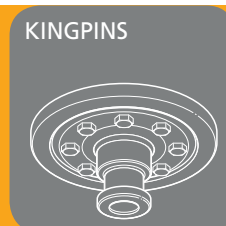

EUROPE · NORTH AMERICA · SOUTH AMERICA · AFRICA · ASIA · AUSTRALIA

SAF-HOLLAND (Xiamen) Co. Ltd.

Shanghai Branch · Room 1006A · Harbour Ring Plaza #18
Xi Zang Middle Road · Shanghai 200001 · China
Phone +86 21 5385 2275 · Fax +86 21 5385 2251
info@safholland.cn

SAF-HOLLAND (Xiamen) Co. Ltd.

DongFu Road #1599 · DongFu Industrial Zone
Haicang District · Xiamen 361027 · China
Phone +86 592 6288 891 · Fax +86 592 6288 892
info@safholland.cn

www.safholland.cn

