

# SAF PENDULUM ZMP09-3015: MORE TRACTION. MORE FLEET FLEXIBILITY. MORE EFFICIENCY – ON DEMAND

The SAF PENDULUM ZMP09-3015 is a drive module for a 9-tonne axle load specially designed for transporting heavy loads under particularly difficult operating conditions. A hydrostatic auxiliary drive which can be switched at any time as required, for example in off-road operation or in extreme winter weather conditions, is completely integrated into the axle. The additional traction available on call already give you more reliability when planning the transport – and thus you specifically increase your fleet flexibility and transport efficiency.

## THE TECHNOLOGY AT A GLANCE

- Installation space is identical to non-driven SAF swivel axle Type SKRZP 12030/15: thus completely compatible
- Maintenance-free, preset grease-lubricated compact bearing: completely separate from the working area and hydraulic circuit of the motor because of a multiple sealing system with overboost protective valve
- Field-tested SNK 300 x 150 SAF brake, compatible with existing vehicle modules with non-driven axles
- Interchangeability of the brake pads and slack adjuster with non-driven SAF pendulum axles is guaranteed
- Outboard drum: brake maintenance (brake pad and drum change) is carried out without disassembling the motors and the wheel-hub unit
- New composite casting technology of the drum
- Use of standard brake cylinders is possible
- Suitable for specially developed 17.5" wheels
- Newly developed M18 x 1.5 wheel bolts with pressure plate
- Use of larger drum brakes (for 19.5" and 22.5" tyres) possible as required
- Switchable hydraulic motor from POCLAIN HYDRAULICS with max. additional 41 kW capacity
- Motor can be switched on or off during the trip (depending on the system configuration of the vehicle)
- During normal driving operation the motor can be completely "disconnected" (depending on the system configuration of the vehicle)
- Motor is independent of driving direction

# THE NEW SWIVEL AXLE WITH SWITCHABLE AUXILIARY DRIVE

To get you along safely and get you there on time.  
Especially when transport job and roadway  
place specific demands – on you and on your fleet.

Weight	approx. 440 kg	Axle Load	max. 9 t at 105 km/h
Rim Unit	710 mm	Wheel Tread	734 mm
Wheels	17.5" x 6.00"	Hydraulic Motor	2 x type MF-MFE 08
Tyres	215-245/75 R 17.5"	Availability	on request

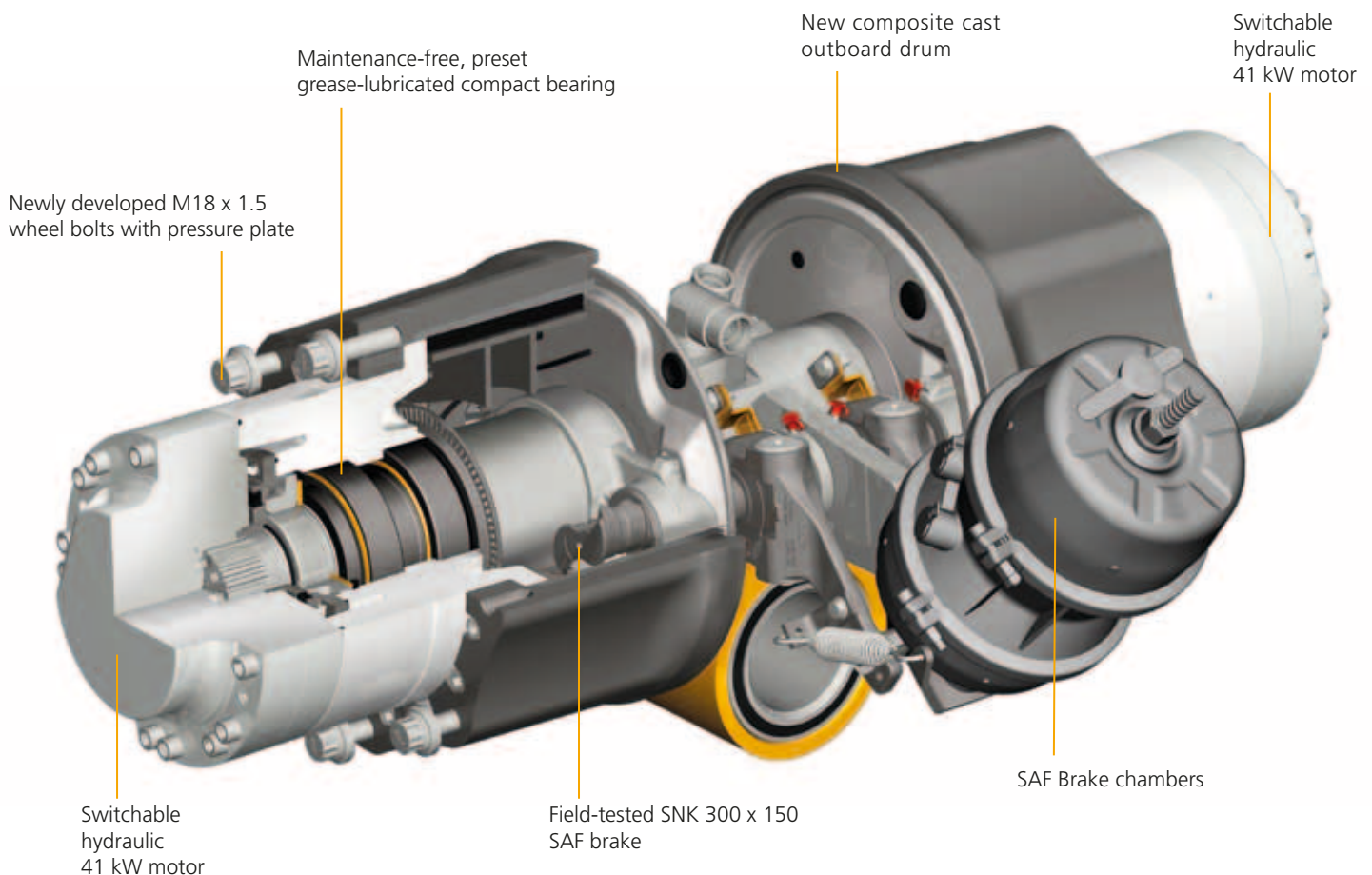

The new SAF PENDULUM ZMP09-3015 can be used either as a trailer or as a self-propelled unit and in many cases can save an additional tractor.