

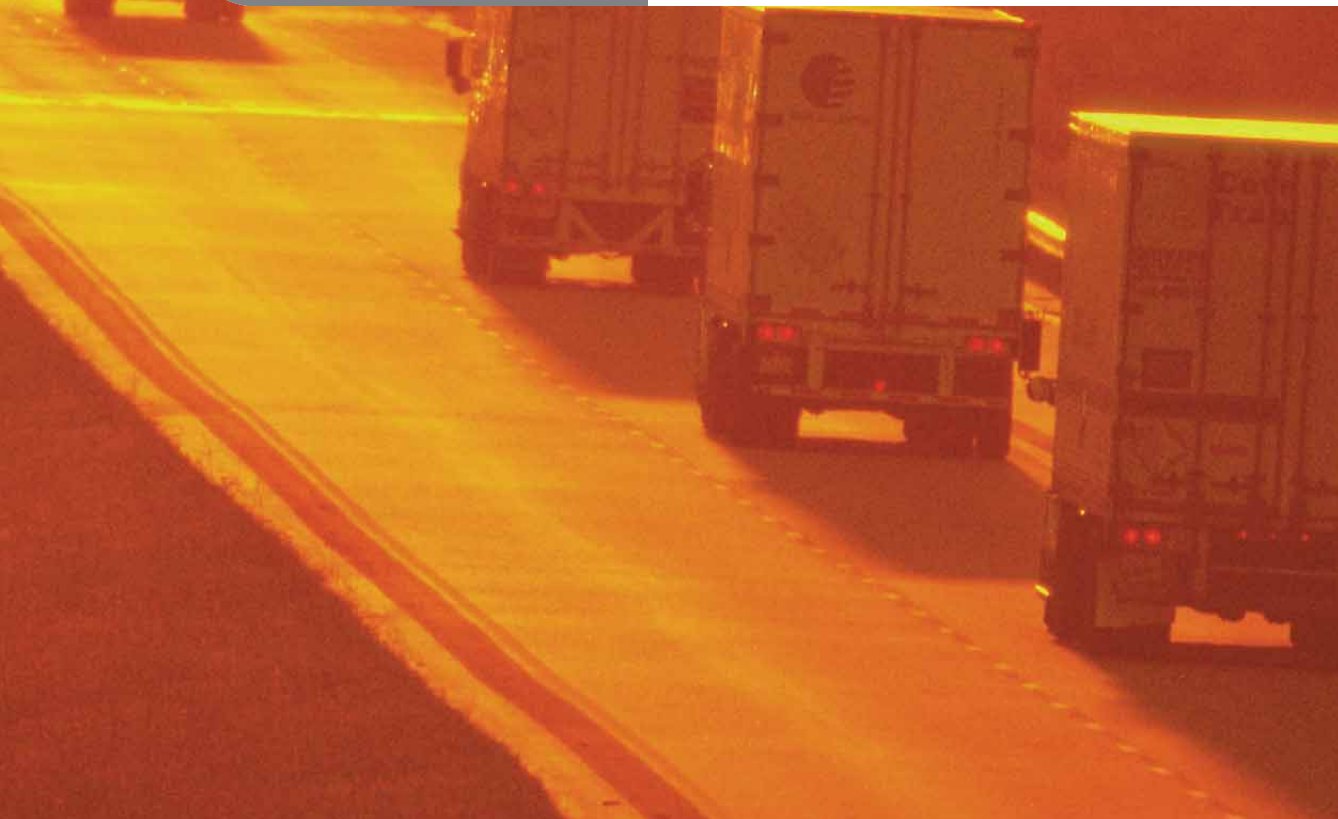

SAF-HOLLAND Group

# HOLLAND LANDING GEAR

REBUILD KIT  
INFORMATION  
FOR HOLLAND  
LANDING GEAR

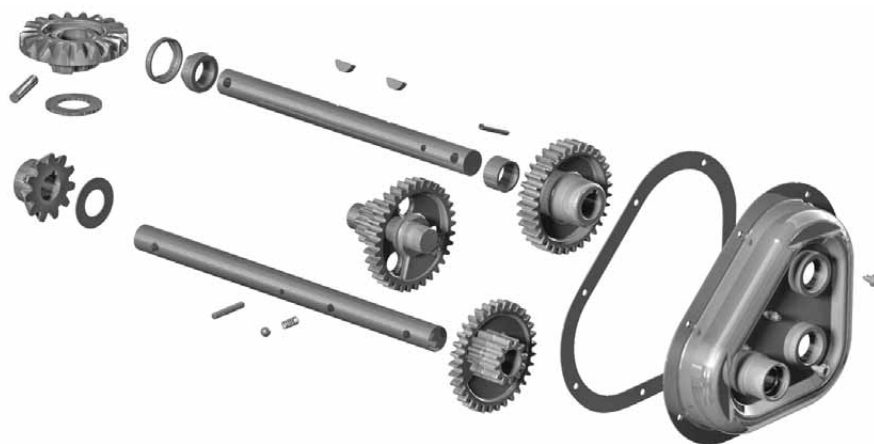



# LANDING GEAR REBUILD KITS

**HOLLAND LANDING GEAR REBUILD KITS BY SAF-HOLLAND ORIGINAL PARTS HELP YOU SAVE TIME AND MONEY BY KEEPING YOUR TRAILER ON THE ROAD.**

Gear Box and Bevel Gear Rebuild Kits by SAF-HOLLAND Original Parts are the best solution for repairing your Holland Landing Gear. No more wasted time looking up part numbers or waiting for individual parts to ship or stock. Rebuild Kits are easy to order through

SAF-HOLLAND Original Parts and contain everything you need for your gear box or bevel gear.

Why struggle to weld brace ears or get shafts to line up with previous mounting holes? Gear Box and Bevel Gear Rebuild Kits by SAF-HOLLAND Original Parts allow you to use your existing landing gear body, and are designed to work perfectly with your Holland landing gear with no welding, cutting, or drilling. There is no need to throw away the entire leg for only a worn bushing or gear; replace the parts quickly and easily with Gear Box and Bevel Gear Rebuild Kits by SAF-HOLLAND Original Parts.

## 51000 SERIES

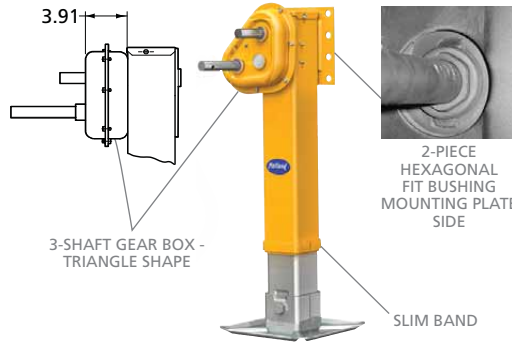
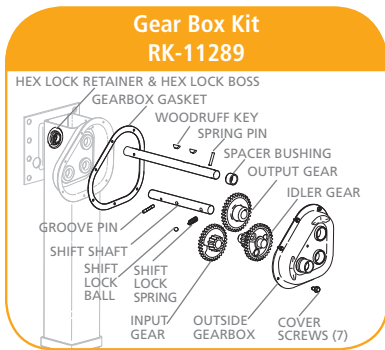

## 50000 SERIES

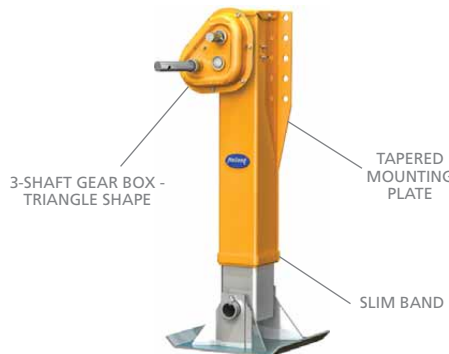

## CMS3

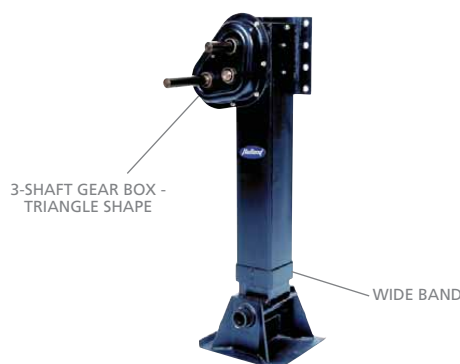
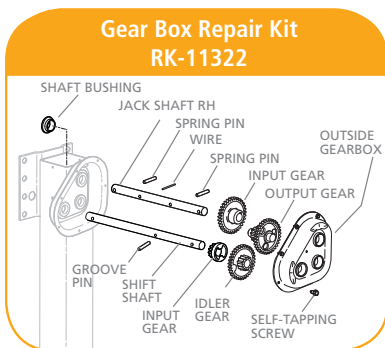

# ATLAS 55

## Bevel & Pinion Gear Kit RK-11442

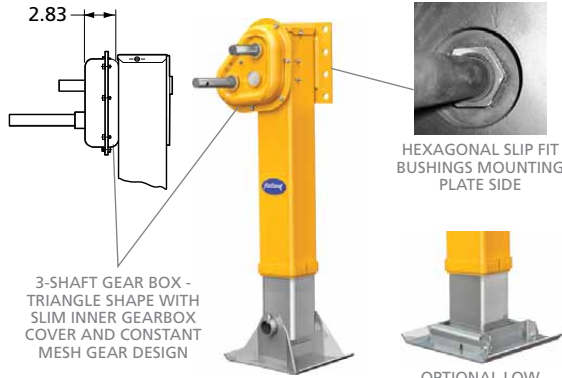
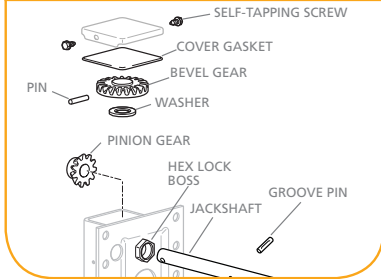

## Gear Box Kit RK-11443

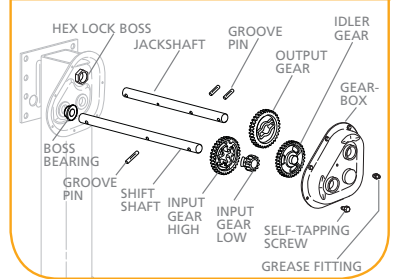

# CMS2 SERIES

## Gear Box Repair Kit RK-11291

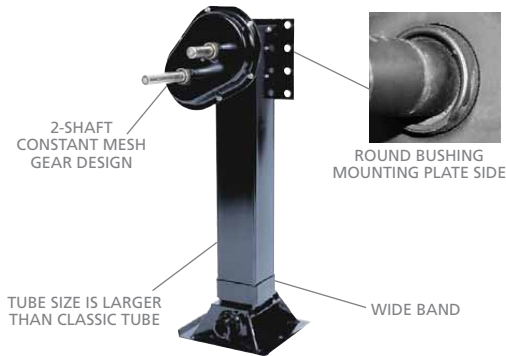
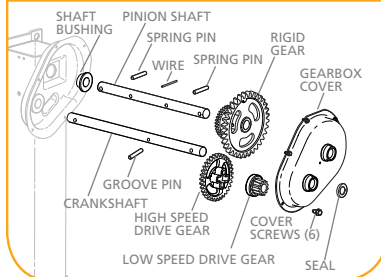

## Bevel & Pinion Gear Kit RK-11290

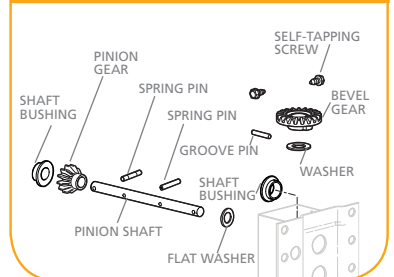

# CLASSIC

## Gear Box Repair Kit RK-11489

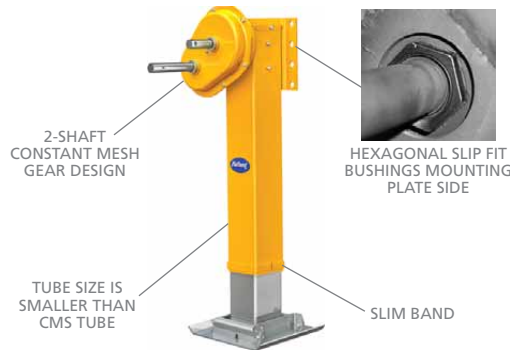
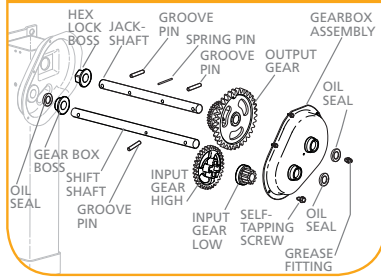

## Bevel & Pinion Gear Kit RK-11488

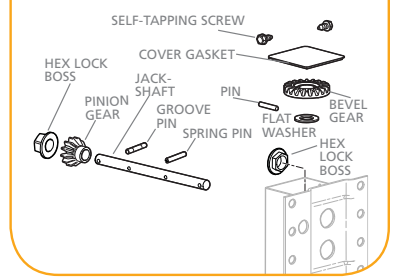

# MARK V & MARK V HD

## Gear Box Repair Kit RK-11287

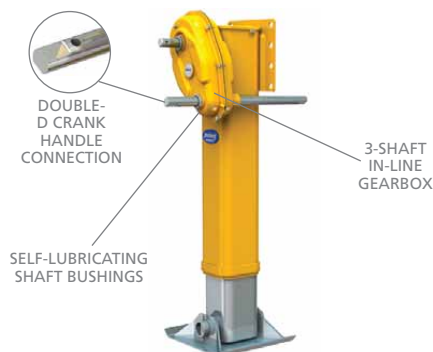
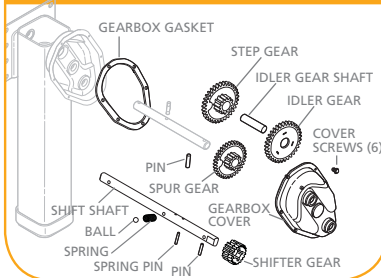

## Bevel & Pinion Gear 1-Speed Leg Repair Kit - RK-11286 2-Speed Leg Repair Kit - RK-11362

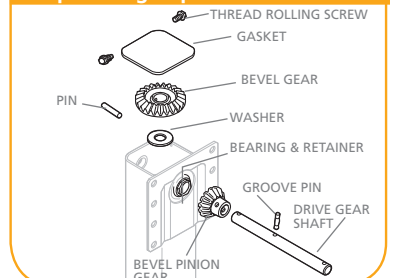



From fifth wheel rebuild kits to suspension bushing repair kits, SAF-HOLLAND Original Parts are the same quality components used in the original component assembly.

SAF-HOLLAND Original Parts are tested and designed to provide maximum performance and durability. Will-fits, look-alikes or, worse yet, counterfeit parts will only limit the performance potential and could possibly void SAF-HOLLAND's warranty. Always be sure to spec SAF-HOLLAND Original Parts when servicing your SAF-HOLLAND product.

**SAF-HOLLAND USA • 800.876.3929 • Fax 800.356.3929**  
[www.safholland.us](http://www.safholland.us)

**SAF-HOLLAND CANADA • 519.537.3494 • Fax 800.565.7753**  
**WESTERN CANADA • 604.574.7491 • Fax 604.574.0244**  
[www.safholland.ca](http://www.safholland.ca)

**SAF-HOLLAND MEXICO • 52.55.53628743 • Fax 52.55.53628743**  
[www.safholland.com.mx](http://www.safholland.com.mx)  
[info@safholland.com](mailto:info@safholland.com)