

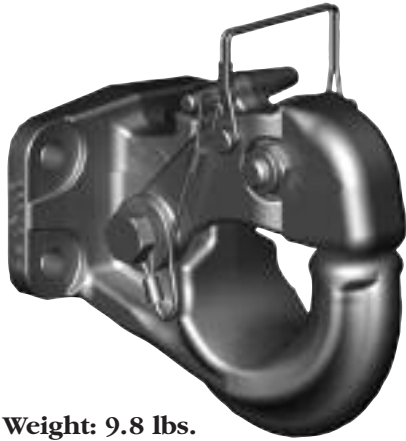

PH-T-60-S10646

PH-T-60-S10646 SPECIFICATIONS



Weight: 9.8 lbs.

IMPORTANT SAFETY INFORMATION:

Maintain adequate vertical (tongue) load to properly control the trailer (generally 10%) but do not exceed the above rated capacities.

DO NOT damage the latch. Be particularly careful with the drawbar when coupling and uncoupling.

Other steps and inspections are also required. Consult OSHA and D.O.T. regulations and American Trucking Association for complete coupling and uncoupling procedures. These cover items such as cargo securement, brakes, lights, safety chains, and other important requirements.

This equipment must not be used or maintained in a careless manner.

GENERAL INFORMATION:

1. Do not modify or add to the product.
2. Wear safety goggles during installation, removal and servicing.
3. Never strike any part of the item with a steel hammer.
4. Do not weld on this product.

This product is covered by SAF-HOLLAND's Commercial Products Warranty. SAF-HOLLAND reserves the right, without giving prior notice, to change specifications and dimensions as designs are altered or improved.

TOWING APPLICATIONS:

Trailers and equipment designed for over-the-road towing within the stated capacities. For off-road applications, reduce the capacities above by 25% and use in conjunction with a swivel type drawbar.

DRAWBAR EYE DIMENSIONS:

2" to 3" I.D. with 1.25" to 1.63" diameter section.

Rigid type pintle hook.

6,000 lbs. Maximum Vertical Load

30,000 lbs. Maximum Gross Trailer Weight

SAE J847 Information:

Type I - not applicable. Type II - 32,000 lbs.

MOUNTING:

1. Use a mounting structure of sufficient strength to support the rated capacity of the pintle hook in accordance with SAE J849 and SAE J847 respectively.
2. Use the hole pattern described on the reverse.
3. Use (4) .5" grade 8 fasteners, properly tightened. The recommended minimum torque is 60 ft-lbs., per SAE J429.

OPERATING INSTRUCTIONS:

1. Before operating, inspect for proper operation, worn, damaged or missing parts and secure mounting. Correct as required before use.
2. Open latch (XA-T-62-O-1L-8) by removing D-ring pin (A) and lifting lock (B).
3. Position drawbar eye over the horn of the pintle and lower into place.
4. Close the latch and insert the D-ring pin. Lock the D-ring pin to retain position.

MAINTENANCE:

For proper performance, the following maintenance steps should be performed every 30,000 miles or 3 months, whichever comes first.

1. Clean and check for proper operation. Inspect for worn, damaged or missing parts. Replace as required using only Holland parts.
2. Inspect, in particular, the coupling contact area and periodically disassemble to inspect for wear on the shank mounting flanges. Replace any component when wear exceeds 1/8" (0.125") from the original surface profile.
3. Regularly lubricate latch pivot with a light oil lubricant.
4. Check mounting fasteners for proper torque.

PH-T-60-S10646

ALL DIMENSIONS SHOWN ARE NOMINAL

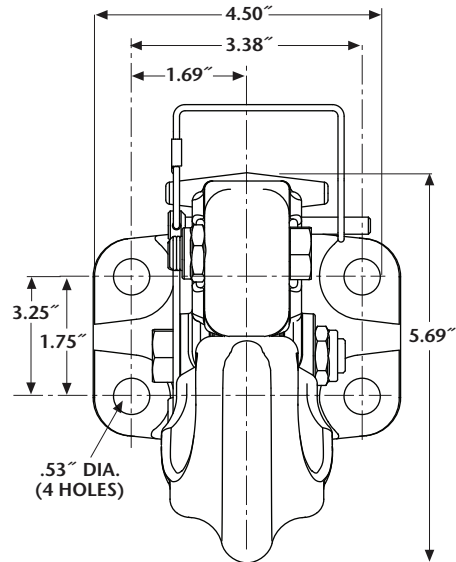
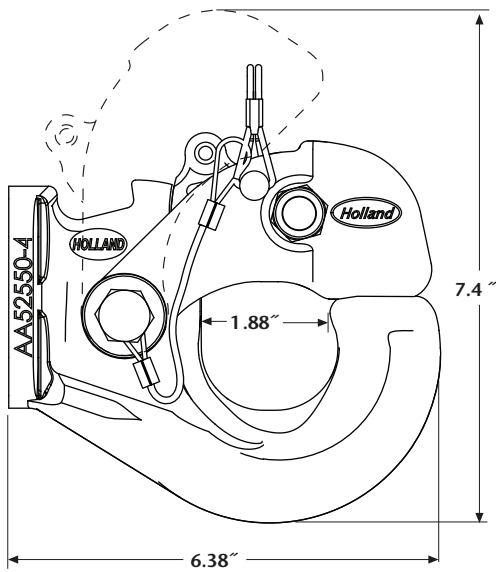
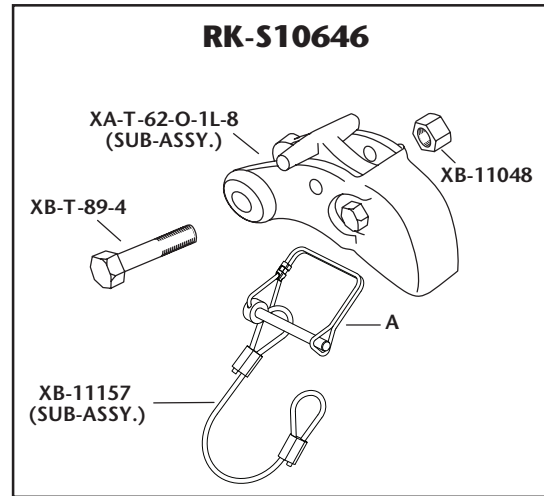
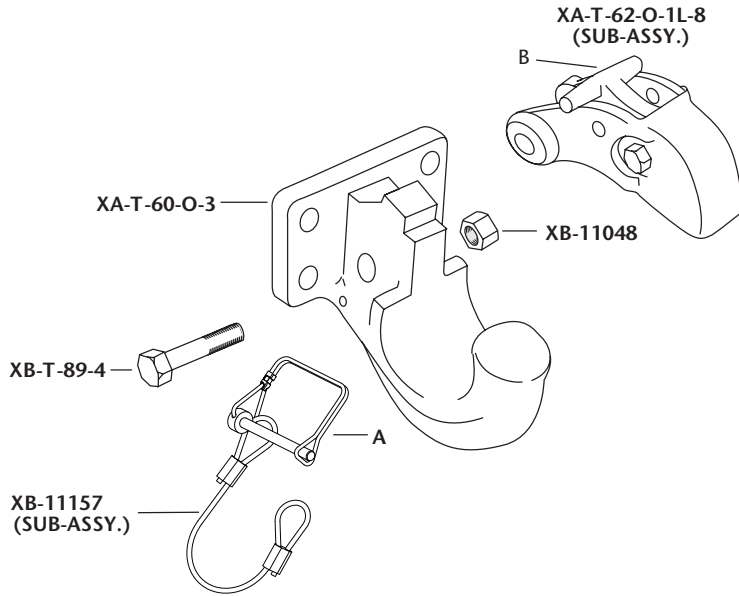

SAF-HOLLAND USA, Inc.
888.396.6501 Fax 800.356.3929

SAF-HOLLAND Canada Limited
519.537.3494 Fax 800.565.7753
Western Canada
604.574.7491 Fax 604.574.0244

SAF-HOLLAND International, Inc.
616.396.6501 Fax 616.356.1511