



SAF-HOLLAND Group

HOLLAND TIRE CARRIER

HEAVY-DUTY
U-FRAME
TIRE CARRIER



HOLLAND TIRE CARRIER

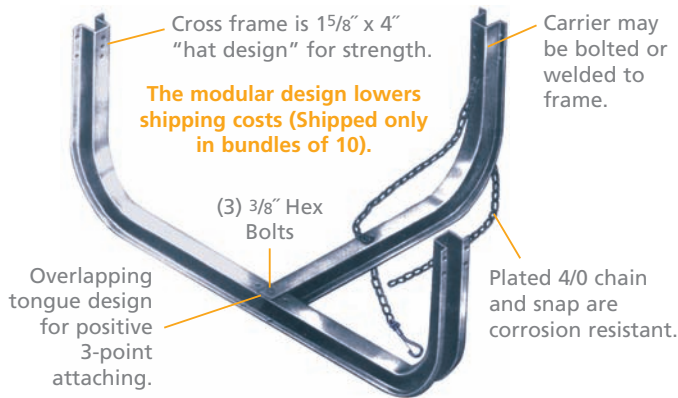

The Holland TS0002 U-Frame heavy-duty tire carrier accommodates up to 11" x 22" tire sizes. Its universal mounting configuration assures easy attachments to virtually any truck or trailer frame.

The tire carrier assembly consists of a cross frame and a rear frame connected by three (3/8") hex bolts and a safety chain with a snap. Both the cross and rear frame members are formed from heavy 13-gauge steel for rugged, durable performance. The one-piece cross frame design provides extra rigidity, and the overlapping tongue feature of the rear frame promotes positive locking between frame members. Hex bolts securely lock these frame members together. The heavy-duty safety chain and snap are plated to maintain strength and resist corrosion.

The TS0002 is finished prime painted and unassembled. It is also available assembled (TS0002-10). The modular construction allows palletized shipping for on-the-spot assembly.

DIMENSIONS AND MOUNTING DATA

Weight: 25 lbs.

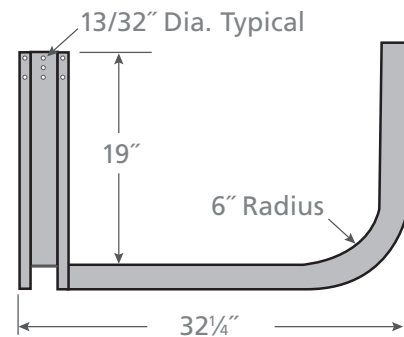
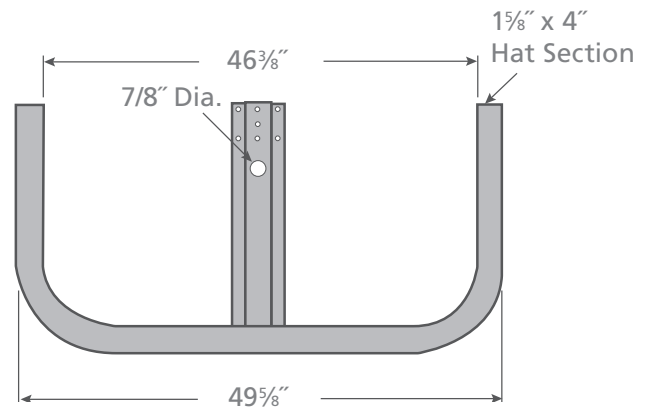

THE TS0002 U-FRAME MODEL MAY BE WELDED OR BOLTED TO THE FRAME.

WARNING

If the spare tire is not properly secured in the carrier, it can dislodge during transit, become a projectile, and cause death or serious injury to people in its path.

- Limit one tire per carrier.
- Tire must have a diameter between 38" and 46".
- Tightly wrap the safety chain around the tire with the end clasp fastened back into the chain.
- Do not use the carrier if the chain or carrier is broken, damaged, or missing parts.

NOTE: The tire carrier will accommodate super single tires, although extra clearance for tire access may be needed on some types of trailers. Varying the method or mounting or the mounting brackets can accommodate this. A longer chain for super single tires is available; specify TS0002-04 (unassembled) or TS0002-12 (assembled).

SAF-HOLLAND, Inc. assumes no responsibility for attachment of the tire carrier to a trailer.

The method of attachment is the sole responsibility of the installer.

SAF-HOLLAND USA, Inc.
888.396.6501 Fax 800.356.3929

SAF-HOLLAND Canada Limited
519.537.3494 Fax 800.565.7753
Western Canada 604.574.7491 Fax 604.574.0244

www.safholland.com

