

SAF AIR SUSPENSION SYSTEM

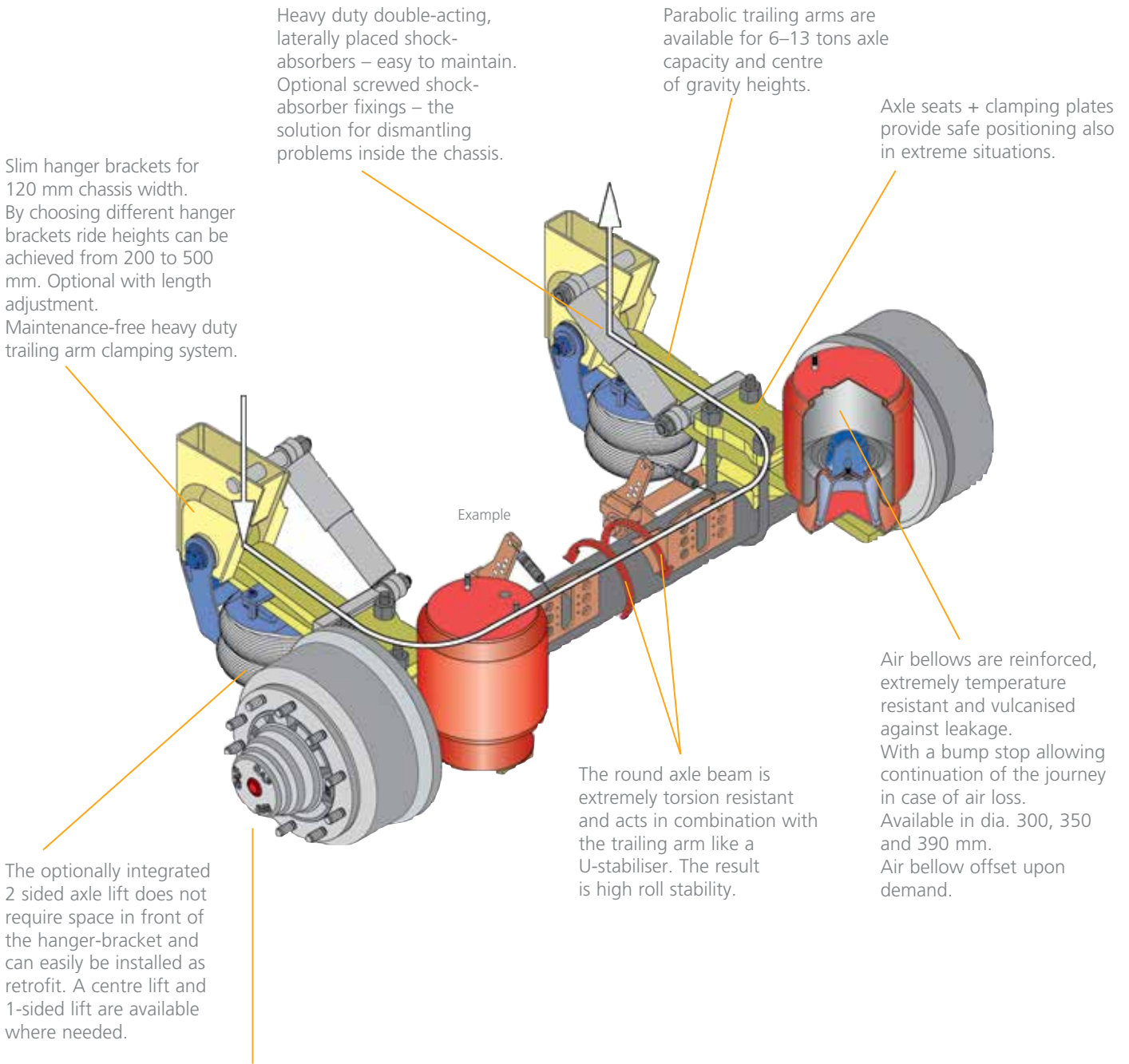

HIGH QUALITY COMPONENTS FOR
TRAILERS AND SEMI-TRAILERS

THE SAF AIR SUSPENSION –



Extremely maintenance friendly and economically during the whole lifetime. Available from 8 to 13 tons axle-capacity.

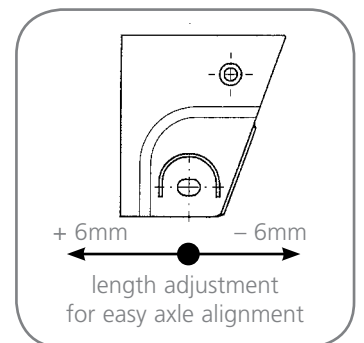
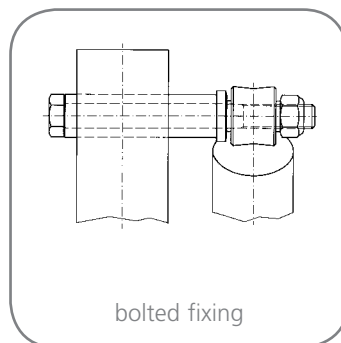

THE ADVANTAGES OF IT'S FUNCTION

AIR-SUSPENSION WORKS ON THE PRINCIPLE OF COMPRESSED AIR

The basic principle is the use of air bellows positioned between the vehicle's axles and chassis so as to use the elastic properties of the air as a suspension medium.

Heavy duty shock absorbers minimize potential shocks to the trailer. The air supply is generated by the brake system and passes via the levelling valve into the air bellows.

THE LEVELLING-VALVE

maintains a constant ride height in all loading situations by adding or releasing air to/from the system

Each air suspension module can be combined to form a single/tandem or triaxle configuration. All suspension modules are mechanically independent.

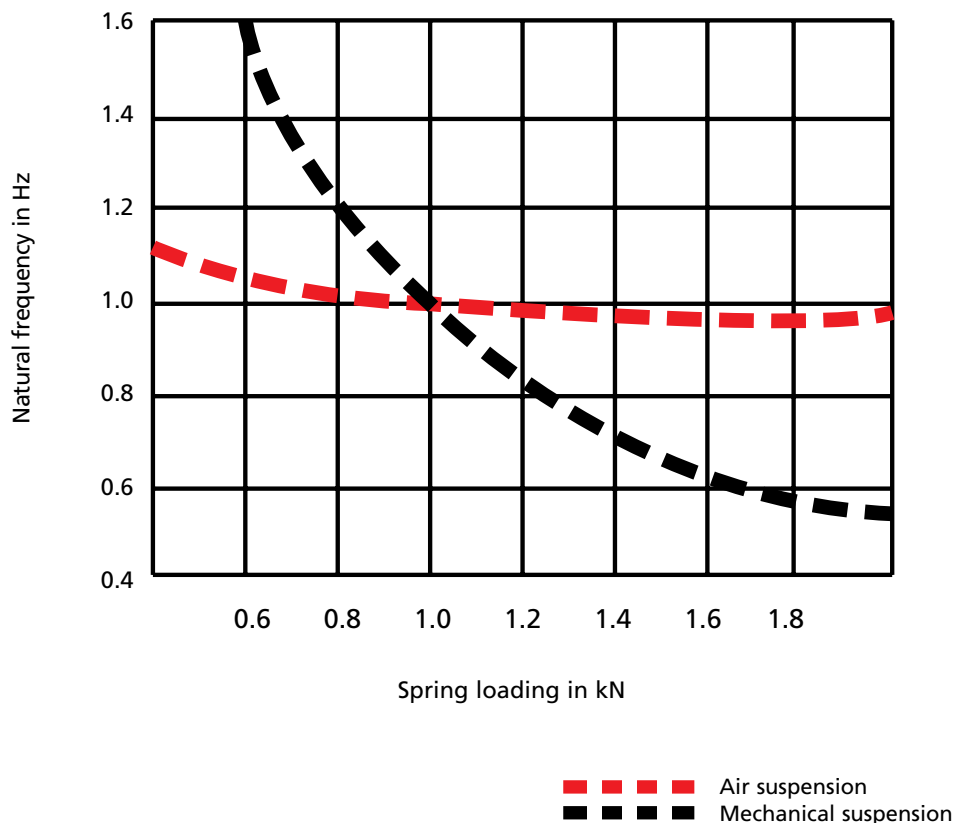

A SPRING RATE ACCOMODATED FOR CHANGING LOAD CONDITION

- no wheel bounce – reduced tyre wear
- comfort for driver
- extended lifetime of chassis and
- optimum protection of load, chassis and road under all driving conditions

THE BENEFITS FOR YOUR BUSINESS

PERFECT LOAD-DISTRIBUTION

- axle travel per module up to 420 mm
- identical load on all axles
- road friendly
- load friendly

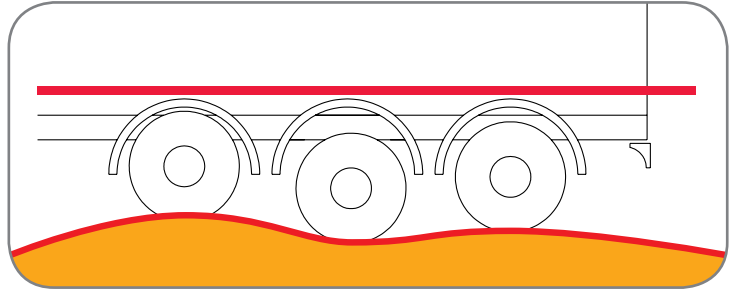

BRAKE SAFETY

- load-dependent brake pressure via the load sensing valve or EBS (electronic braking system)
- balanced braking
- reduced wear of friction materials and tyres

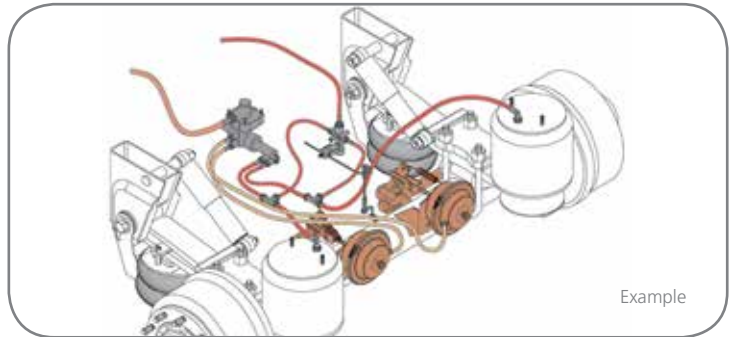

OPTIONAL AXLE LIFT(S)

- reduced tyre wear
- less fuel consumption

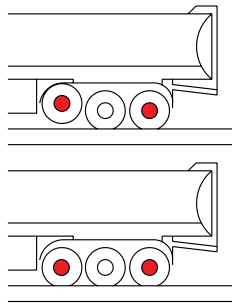

OPTIONAL CHASSIS RAISE AND LOWER FACILITY

- time saving loading on different ramp heights
- swap body operation

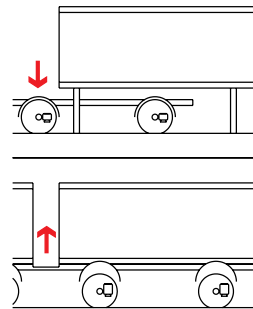

As early as 1964, SAF was the first European manufacturer to develop and introduce workable air suspension systems. The main features of today's modul suspension:

- robust construction, although light in weight
- high lateral stability
- low maintenance
- full product range including, useful options.



SAF-HOLLAND is a leading supplier of highly efficient components, systems and service programmes in the global commercial vehicle industry. Our three core product brands are recognised for delivering innovative solutions that optimise fleet operations in every corner of the world.



TRAILER AXLES AND
SUSPENSION SYSTEMS



COUPLING AND LIFTING
TECHNOLOGY



SUSPENSIONS FOR
TRUCKS AND BUSES

With our team of over 3,000 employees and a worldwide network of over 9,000 service partners, we serve our fleet customers with know-how and passion, and always focus on one target: **Engineering Your Road to Success**. Anywhere in the world. Under any conditions. 365 days a year.

HIGHLY EFFICIENT COMPONENTS AND SYSTEMS FOR TRUCKS AND TRAILERS



EUROPE | NORTH AMERICA | SOUTH AMERICA | AFRICA | ASIA | AUSTRALIA

safholland.com

SAF-HOLLAND GmbH
Hauptstraße 26 · 63856 Bessenbach · Germany
Tel +49 6095 301-0 · info@safholland.de