

Hercules landing gear

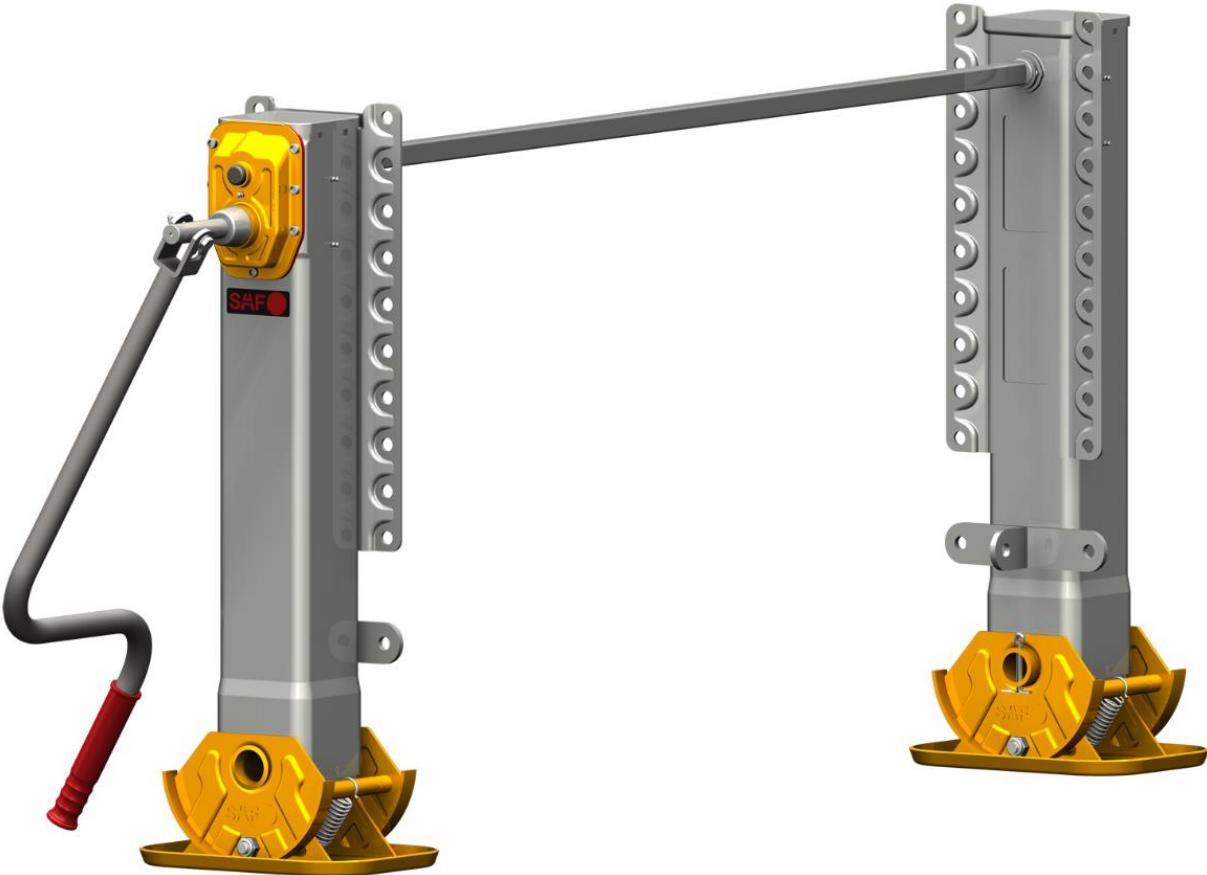

Contents

General information	3
Type plate	3
Type key.....	4
Glossary.....	4
Technical data	5
Hercules variants	6
Hercules mounting plates.....	9
Hercules foot variants.....	10
Hercules geometric specifications.....	11
Hercules installation drawing.....	14
Hercules "Compact" variants	15
Hercules "Compact" mounting plate	15
Hercules "Compact" geometric specifications	16
Hercules "Compact" installation drawing	16
Accessories	17
Connecting shaft	17
Crank.....	18
Crank holder	19
Bracket for braces.....	19
Hercules "drawbar support / swivel support" variants.....	20
Special technical feature	20
Hercules "drawbar support / swivel support" mounting plate.....	20
Hercules "drawbar support / swivel support" geometric specifications.....	21
Hercules "drawbar support / swivel support" installation drawing	21
Drop leg variant	22
Special technical feature	22
Drop leg mounting plate	23
Drop leg geometric specifications	23
Selection	24
Support mounting instructions	24
Crank mounting instructions.....	24
Mounting instructions.....	25
Mounting tolerances	26
Bracing.....	27
Installation instructions	28
Surface coating information	29
Operation	29
At a glance	29

General information

The landing gear is used as a lifting device during unhitching and hitching and as a support device during the parking of semi-trailers.

The support device is only intended for attachment to a trailer which is used in geographical Europe. The country-specific road traffic regulations must be observed.

Type plate



Type key

Example: LGH G 85-51 T S
 LGH G 85 - 51 T S
 XXX0 X 00-00 X X

Letters marked with „X“
 Numbers marked with „0“

Foot type:

S = Compensating shoe (standard)
 T = Sandshoe high
 TC = Sandshoe low
 R = Wheel shoe
 A = Rocker shoe
 C = Round plate shoe
 D = Fixed plate shoe

Mounting plate:

T = top S = swiveling
 B = bottom F = full length C = adaptable

Mounting height:

(first two digits is the mounting height in cm)
 (last two digits is the travel in cm)

Hercules

85 – 51
 80 – 46
 75 – 41
 70 – 40 (only with foot type S)
 70 – 36
 65 – 35 (only with foot type S)
 65 – 31

Gear unit:

O = Landing leg without gear unit
 G = Landing leg with gear unit
 S = Set (all parts together)

Series:

LGH = Landing gear „Hercules“ LGHD = Landing gear „Hercules Drawbar“
 LGHC = Landing gear „Hercules Compact“
 LGDL = Landing gear „Drop-Leg“

The mounting height changes with the different foot variants, while the stroke remains the same.

Glossary

- A Distance between connecting shaft and brace bracket
- B Crank length
- C Distance between landing gear contact surface and inside of crank (low gear)
- D Distance between landing gear contact surface and inside of crank (fast gear)
- E Length of connecting shaft (= F - 30mm)
- F Distance between landing gear
- G Foot height
- H1 Ground clearance
- H2 Stroke reserve
- L Crank holder length
- T Travel
- M Mounting height

- ON Order number
- SN Serial number

Technical data

Table 1

Technical data of the SAF support devices				
Landing gear	Hercules	Hercules Compact	Hercules Drawbar support / swivel support	Drop leg
Lifting load	24.000kg	24.000kg	4.000kg	-
Static load	50.000kg	50.000kg	8.000kg	-
Static support load	-	-	-	15.000kg per Unit
Stroke per crank revolution				
Low gear	1 mm per revolution	1 mm per revolution	7,12 mm per revolution	-
Fast gear	12 mm per revolution	12 mm per revolution		-

The lifting load and the static load for **Hercules** and **Hercules Compact** apply to a landing gear set. The lifting load per landing gear applies with the **Hercules drawbar support**

The **Hercules** and **Hercules Compact** landing gears have a 2-speed gear unit (low gear and fast gear).

Shifting the fast gear or the low gear on the **Hercules** and **Hercules Compact** landing gears are easy to do by pulling and pressing the crank. The fast gear is used to retract and extend the foot of the landing gear until it touches the ground. The low gear is used to raise and lower the empty and loaded vehicle to the appropriate coupling height.

The **Hercules drawbar** landing gear has a 1-speed gear unit.

Hercules variants

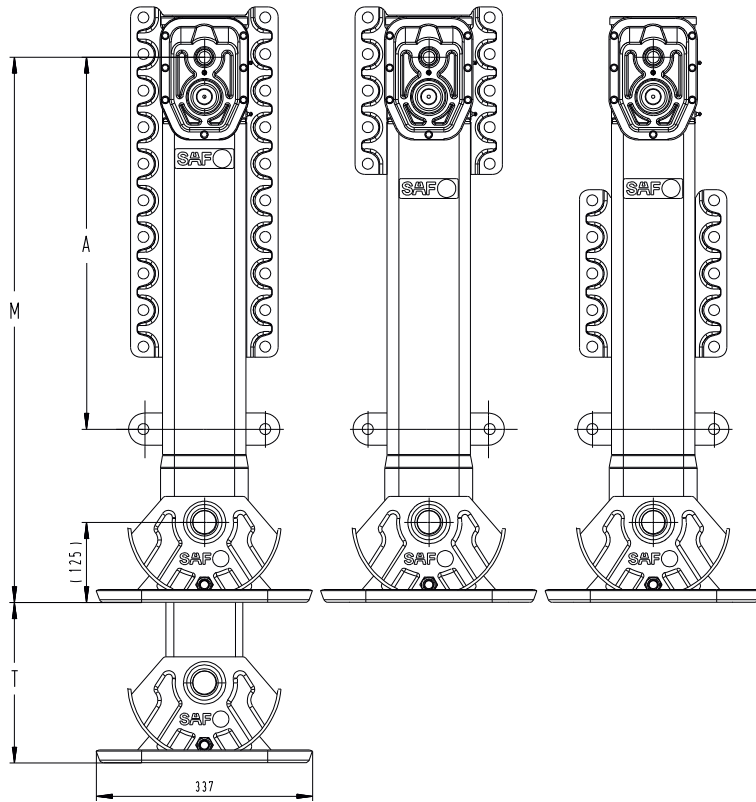

Figure 1

With compensating shoe Type S		
M [mm]	T [mm]	A [mm]
850	510	580
800	460	530
750	410	- / *480
705	400	- / *430
655	350	- / *380

See table 2

* With mounting plate "Top"

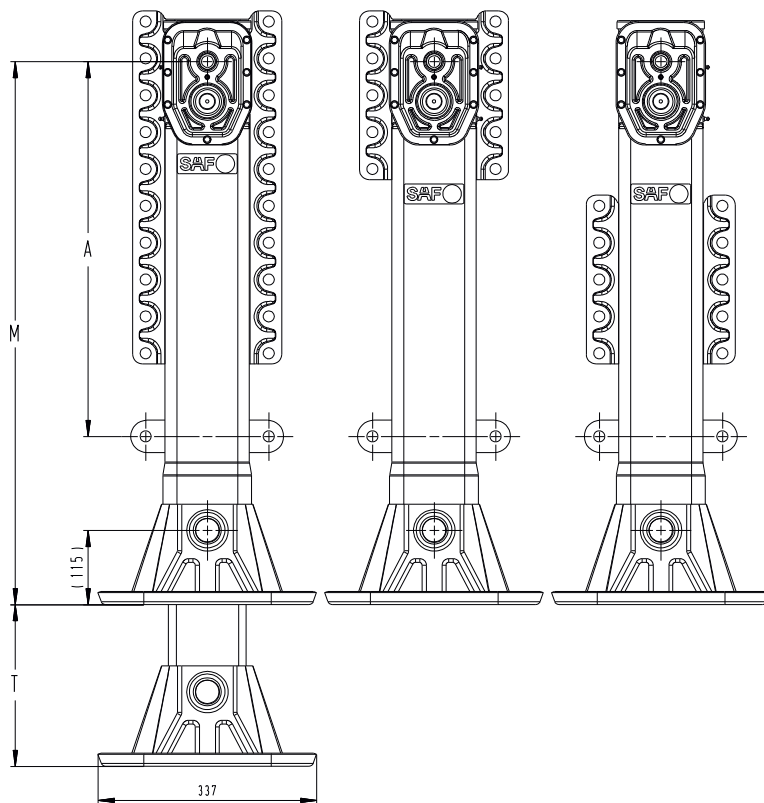

Figure 2

With sandshoe high Type T		
M [mm]	T [mm]	A [mm]
840	510	580
790	460	530
740	410	- / *480
690	360	- / *430
640	310	- / *380

See table 3

* With mounting plate "Top"

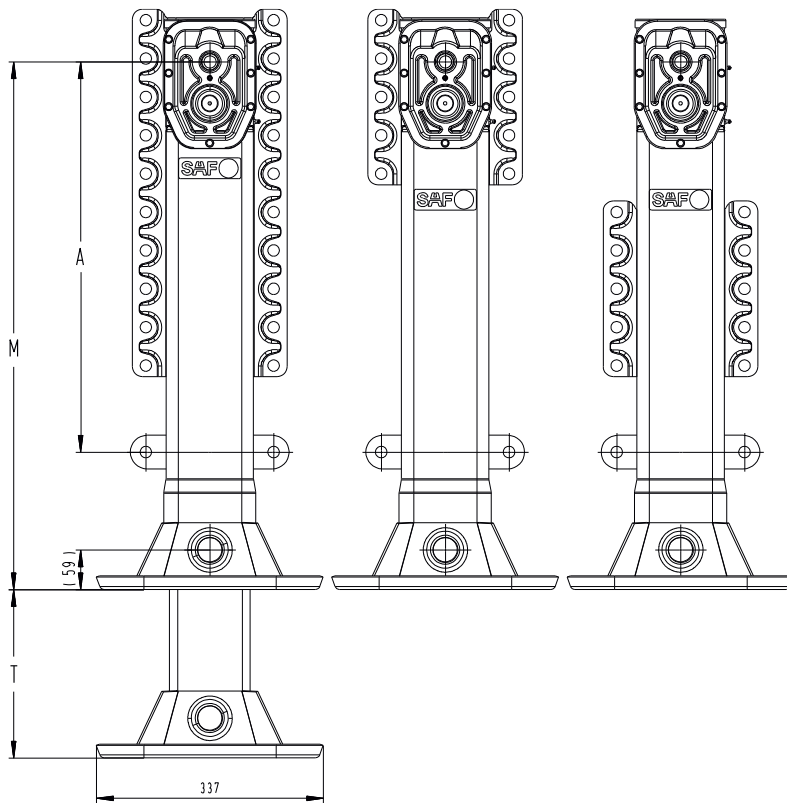

Figure 3

With sandshoe low Type TC		
M [mm]	T [mm]	A [mm]
785	510	580
735	460	530
685	410	-/ *480
635	360	-/ *430
685	310	-/ *380

See table 4

* With mounting plate "Top"

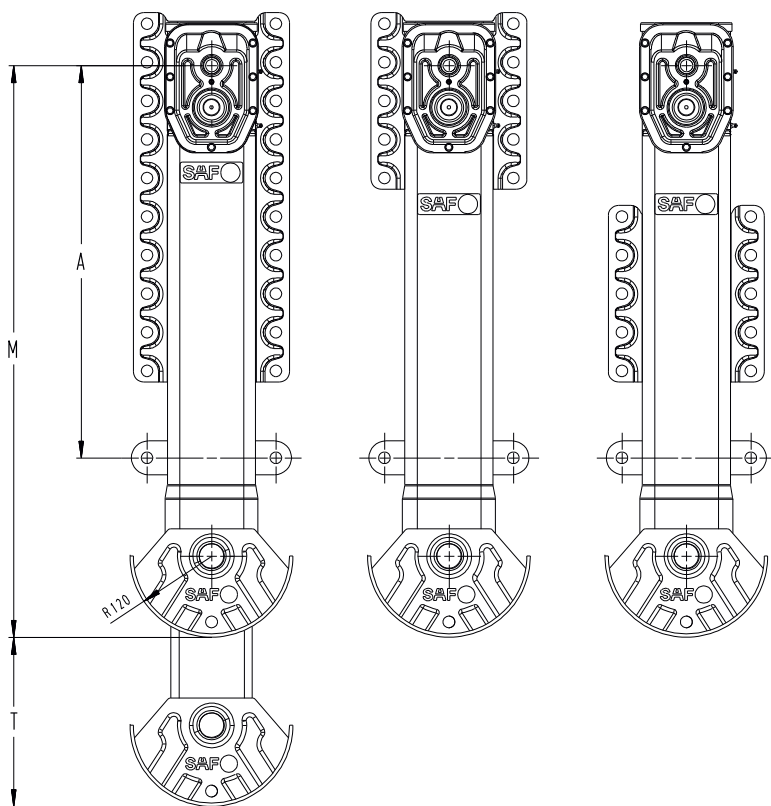

Figure 4

With rocker shoe Type A		
M [mm]	T [mm]	A [mm]
845	510	580
795	460	530
745	410	-/ *480
695	360	-/ *430
645	310	-/ *380

See table 5

* With mounting plate "Top"

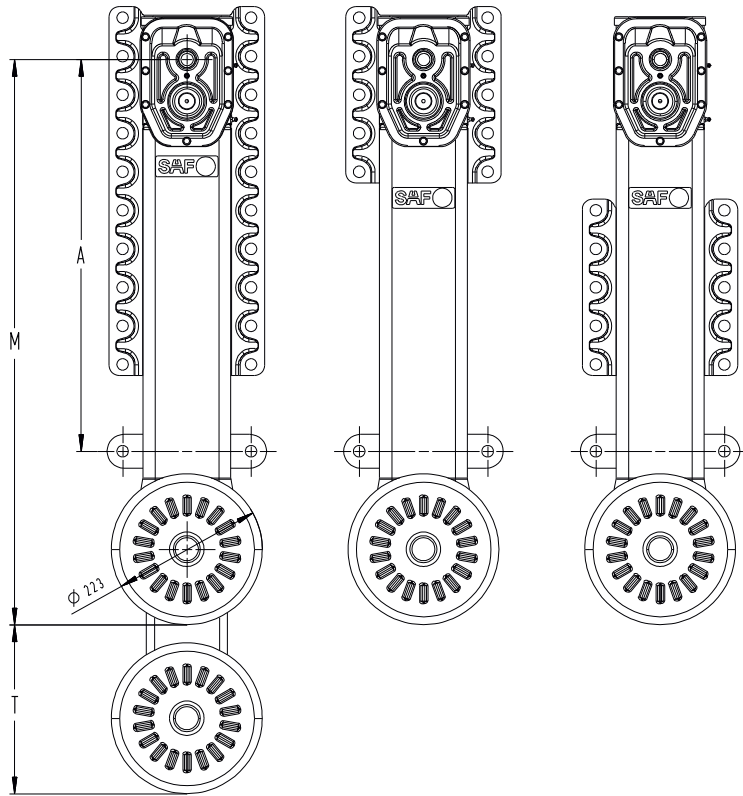

Figure 5

With wheel shoe Type R		
M [mm]	T [mm]	A [mm]
835	510	580
785	460	530
735	410	-/ *480
*685	*360	-/ *430
*635	*310	-/ *380

See table 6

* With mounting plate "Top"

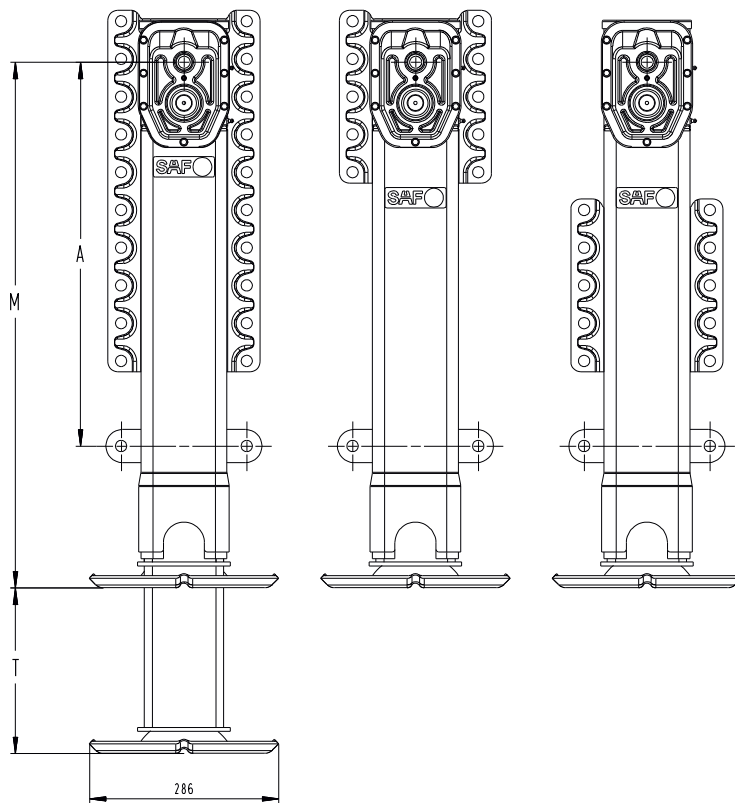

Figure 6

With round plate shoe Type C		
M [mm]	T [mm]	A [mm]
795	510	580
645	460	530
695	410	-/ *480
645	360	-/ *430
595	310	-/ *380

See table 7

* With mounting plate "Top"

Hercules mounting plates

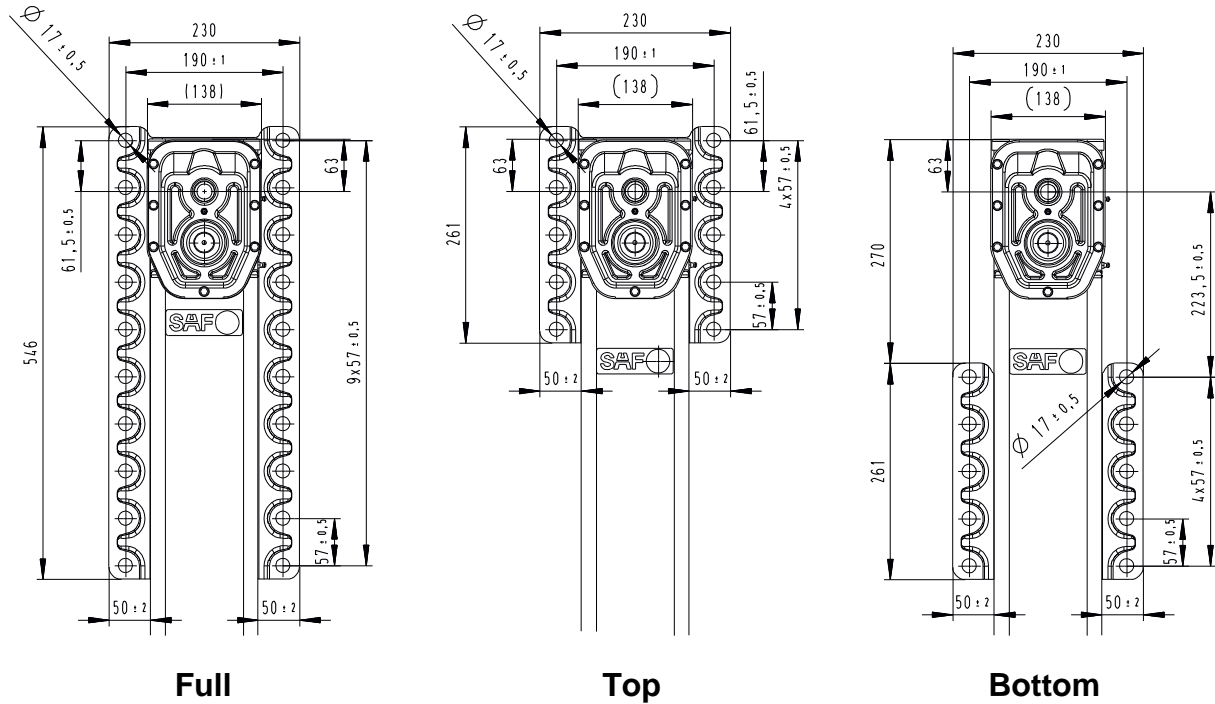

Figure 7

We recommend using M16 (min. strength class 8.8) with washers to screw the mounting plates to the frame of the vehicle. Follow the mounting instructions [Page 27](#).

See [Figure 27-28](#).

These mounting plates allow a large variety of mounting variations.

The clearance towards other components must be assured.

Hercules foot variants

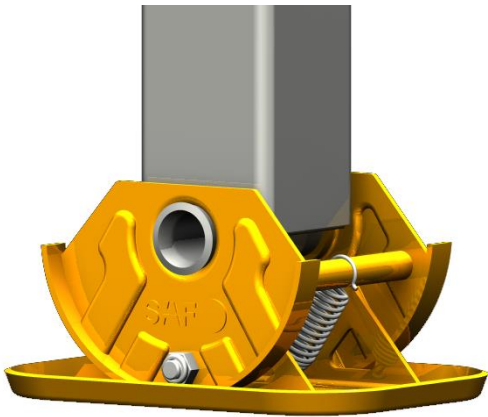

Figure 8 a
Compensating shoe 02 370 1000/1006 00

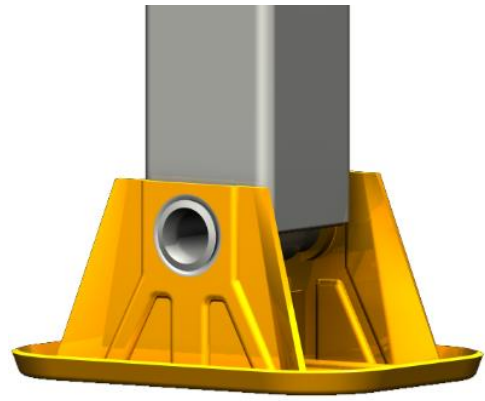

Figure 8 b
Sandshoe high 02 370 1001 00

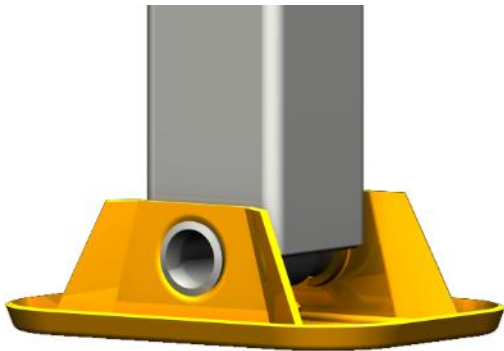

Figure 8 c
Sandshoe low 02 370 1004 00

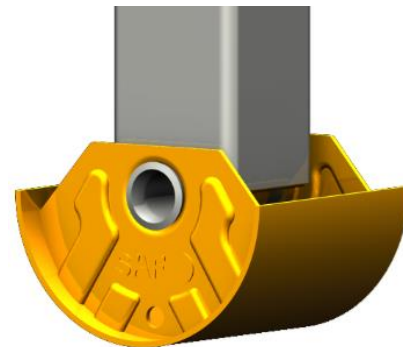

Figure 8 d
Rocker shoe 02 370 1002 00

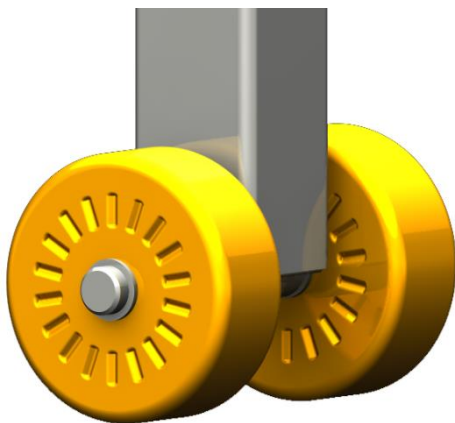

Figure 8 e
Wheel shoe 02 370 1003 00

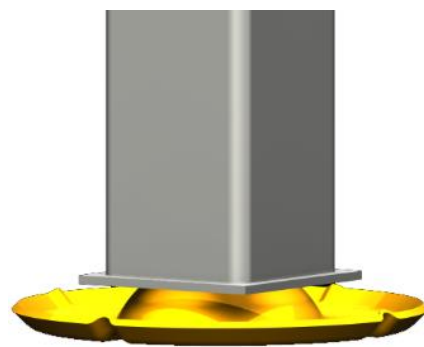

Figure 8 f
Round plate shoe 02 370 1005 00

Hercules geometric specifications

Landing leg with foot Type S

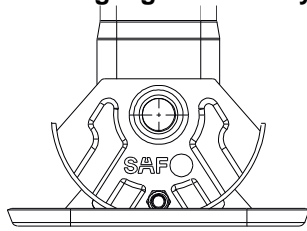

Figure 9 a

Table 2

Landing leg with compensating shoe Type S / Part number				Mounting height	Travel	Bracket for brace	
with gear (with foot)	Weight [kg]	without gear (with foot)	Weight [kg]	M [mm]	T [mm]	A [mm]	
Mounting plate "FULL"							
03 389 0010 00	42,3	03 389 0009 00	38,7	655	350	-	
03 389 0008 00	44	03 389 0007 00	40,4	705	400	-	
03 389 0006 00	45,3	03 389 0005 00	41,7	750	410	-	
03 389 0004 00	46,9	03 389 0003 00	43,3	800	460	530	
03 389 0002 00	48,5	03 389 0001 00	45	850	510	580	
Mounting plate "TOP"							
03 389 0210 00	40,8	03 389 0209 00	37,2	655	350	380	
03 389 0208 00	42,5	03 389 0207 00	39	705	400	430	
03 389 0206 00	43,6	03 389 0205 00	40	750	410	480	
03 389 0204 00	44,4	03 389 0203 00	40,8	800	460	530	
03 389 0202 00	46	03 389 0201 00	42,5	850	510	580	
Mounting plate "BOTTOM"							
03 389 0110 00	40,8	03 389 0109 00	37,2	655	350	-	
03 389 0108 00	42,5	03 389 0107 00	39	705	400	-	
03 389 0106 00	43,6	03 389 0105 00	40	750	410	-	
03 389 0104 00	44,4	03 389 0103 00	40,8	800	460	530	
03 389 0102 00	46	03 389 0101 00	42,5	850	510	580	

Landing leg with foot Type T

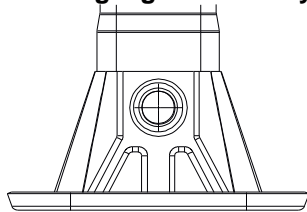

Figure 9 b

Table 3

Landing leg with sandshoe high Type T / Part number				Mounting height	Travel	Bracket for brace	
with gear (with foot)	Weight [kg]	without gear (with foot)	Weight [kg]	M [mm]	T [mm]	A [mm]	
Mounting plate "FULL"							
03 389 0020 00	40,3	03 389 0019 00	36,8	640	310	-	
03 389 0018 00	42	03 389 0017 00	38,5	690	360	-	
03 389 0016 00	43,7	03 389 0015 00	40,2	740	410	-	
03 389 0014 00	45,3	03 389 0013 00	41,8	790	460	530	
03 389 0012 00	47	03 389 0011 00	43,5	840	510	580	
Mounting plate "TOP"							
03 389 0220 00	38	03 389 0219 00	34,5	640	310	380	
03 389 0218 00	39,5	03 389 0217 00	36	690	360	430	
03 389 0216 00	41,2	03 389 0215 00	38,5	740	410	480	
03 389 0214 00	42,8	03 389 0213 00	39,3	790	460	530	
03 389 0212 00	44,5	03 389 0211 00	41	840	510	580	
Mounting plate "BOTTOM"							
03 389 0120 00	38	03 389 0119 00	34,5	640	310	-	
03 389 0118 00	39,5	03 389 0117 00	36	690	360	-	
03 389 0116 00	41,2	03 389 0115 00	38,5	740	410	-	
03 389 0114 00	42,8	03 389 0113 00	39,3	790	460	530	
03 389 0112 00	44,5	03 389 0111 00	41	840	510	580	

Landing leg with foot Type TC

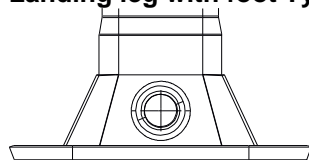

Figure 9 c

Table 4

Landing leg with sandshoe low Type TC / Part number				Mounting height	Travel	Bracket for brace
with gear (with foot)	Weight [kg]	without gear (with foot)	Weight [kg]	M [mm]	T [mm]	A [mm]
Mounting plate "FULL"						
03 389 0030 00	38,8	03 389 0029 00	35,3	585	310	-
03 389 0028 00	40,5	03 389 0027 00	37	635	360	-
03 389 0026 00	42,2	03 389 0025 00	38,7	685	410	-
03 389 0024 00	43,8	03 389 0023 00	40,3	735	460	530
03 389 0022 00	45,5	03 389 0021 00	42	785	510	580
Mounting plate "TOP"						
03 389 0230 00	36,5	03 389 0229 00	33	585	310	380
03 389 0228 00	38	03 389 0227 00	34,5	635	360	430
03 389 0226 00	40,5	03 389 0225 00	37	685	410	480
03 389 0224 00	41,3	03 389 0223 00	37,8	735	460	530
03 389 0222 00	43	03 389 0221 00	39,5	785	510	580
Mounting plate "BOTTOM"						
03 389 0130 00	36,5	03 389 0129 00	33	585	310	-
03 389 0128 00	38	03 389 0127 00	34,5	635	360	-
03 389 0126 00	40,5	03 389 0125 00	37	685	410	-
03 389 0124 00	41,3	03 389 0123 00	37,8	735	460	530
03 389 0122 00	43	03 389 0121 00	39,5	785	510	580

Landing leg with foot Type A

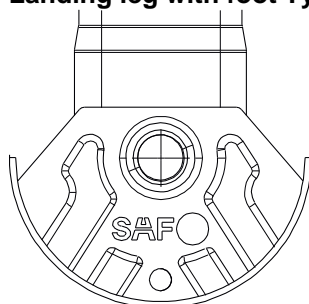

Figure 9 d

Table 5

Landing leg with rocker shoe Type A / Part number				Mounting height	Travel	Bracket for brace
with gear (with foot)	Weight [kg]	without gear (with foot)	Weight [kg]	M [mm]	T [mm]	A [mm]
Mounting plate "FULL"						
03 389 0040 00	41,6	03 389 0039 00	38,2	645	310	-
03 389 0038 00	43,3	03 389 0037 00	39,8	695	360	-
03 389 0036 00	44,9	03 389 0035 00	41,5	745	410	-
03 389 0034 00	46,6	03 389 0033 00	43,1	795	460	530
03 389 0032 00	48,3	03 389 0031 00	44,8	845	510	580
Mounting plate "TOP"						
03 389 0240 00	39,3	03 389 0239 00	36	645	310	380
03 389 0238 00	40,8	03 389 0237 00	37,5	695	360	430
03 389 0236 00	43,2	03 389 0235 00	39,8	745	410	480
03 389 0234 00	44,1	03 389 0233 00	40,6	795	460	530
03 389 0232 00	45,8	03 389 0231 00	42,3	845	510	580
Mounting plate "BOTTOM"						
03 389 0140 00	39,3	03 389 0139 00	36	645	310	-
03 389 0138 00	40,8	03 389 0137 00	37,5	695	360	-
03 389 0136 00	43,2	03 389 0135 00	39,8	745	410	-
03 389 0134 00	44,1	03 389 0133 00	40,6	795	460	530
03 389 0132 00	45,8	03 389 0131 00	42,3	845	510	580

Landing leg with foot Type R

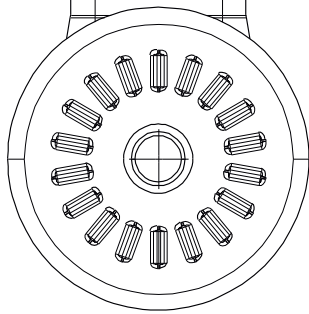

Figure 9 e

Table 6

Landing leg with wheel shoe Type R / Part number				Mounting height	Travel	Bracket for brace
with gear (with foot)	Weight [kg]	without gear (with foot)	Weight [kg]	M [mm]	T [mm]	A [mm]
Mounting plate "FULL"						
03 389 0046 00	50,3	03 389 0045 00	46,8	735	410	-
03 389 0044 00	51,9	03 389 0043 00	48,4	785	460	530
03 389 0042 00	53,6	03 389 0041 00	50,1	835	510	580
Mounting plate "TOP"						
03 389 0250 00	44,5	03 389 0249 00	42,2	635	310	380
03 389 0248 00	46	03 389 0247 00	43,7	685	360	430
03 389 0246 00	48,5	03 389 0245 00	45,9	735	410	480
03 389 0244 00	49,3	03 389 0243 00	46,8	785	460	530
03 389 0242 00	51	03 389 0241 00	48,5	835	510	580
Mounting plate "BOTTOM"						
03 389 0146 00	48,5	03 389 0145 00	45,9	735	410	-
03 389 0144 00	49,3	03 389 0143 00	46,8	785	460	530
03 389 0142 00	51	03 389 0141 00	48,5	835	510	580

Landing leg with foot Type C

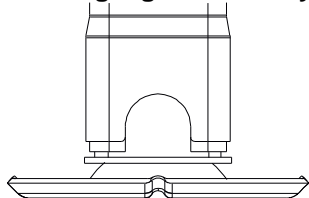

Figure 9 f

Table 7

Landing leg with round plate shoe Type C / Part number				Mounting height	Travel	Bracket for brace
with gear (with foot)	Weight [kg]	without gear (with foot)	Weight [kg]	M [mm]	T [mm]	A [mm]
Mounting plate "FULL"						
03 389 0060 00	40,6	03 389 0059 00	37	595	310	-
03 389 0058 00	42,2	03 389 0057 00	38,6	645	360	-
03 389 0056 00	43,6	03 389 0055 00	40,3	695	410	-
03 389 0054 00	45,5	03 389 0053 00	42	745	460	530
03 389 0052 00	47,2	03 389 0051 00	43,6	795	510	580
Mounting plate "TOP"						
03 389 0260 00	39,3	03 389 0259 00	34,8	595	310	380
03 389 0258 00	39,7	03 389 0257 00	36,1	645	360	430
03 389 0256 00	42,2	03 389 0255 00	38,6	695	410	480
03 389 0254 00	43	03 389 0253 00	39,5	745	460	530
03 389 0252 00	44,7	03 389 0251 00	41,1	795	510	580
Mounting plate "BOTTOM"						
03 389 0160 00	39,3	03 389 0159 00	34,8	595	310	-
03 389 0158 00	39,7	03 389 0157 00	36,1	645	360	-
03 389 0156 00	42,2	03 389 0155 00	38,6	695	410	-
03 389 0154 00	43	03 389 0153 00	39,5	745	460	530
03 389 0152 00	44,7	03 389 0151 00	41,1	795	510	580

Hercules installation/complete set drawing

With full mounting plate

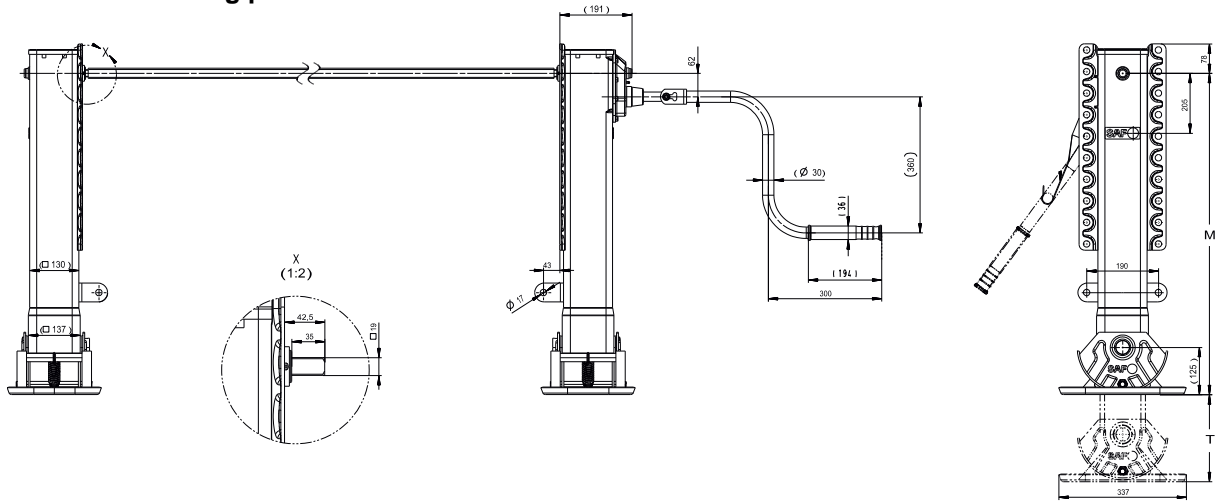

With top mounting plate

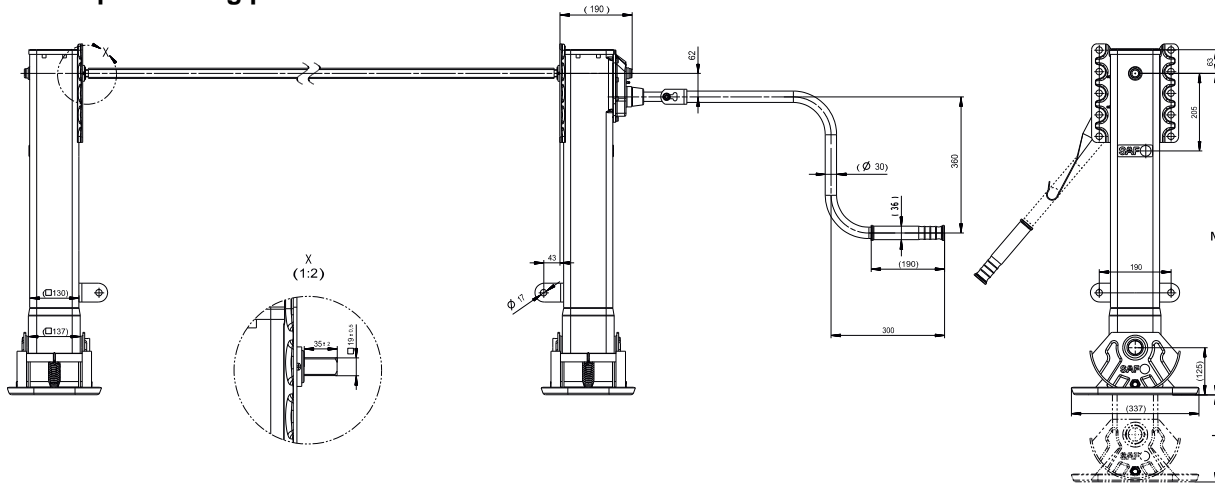

With bottom mounting plate

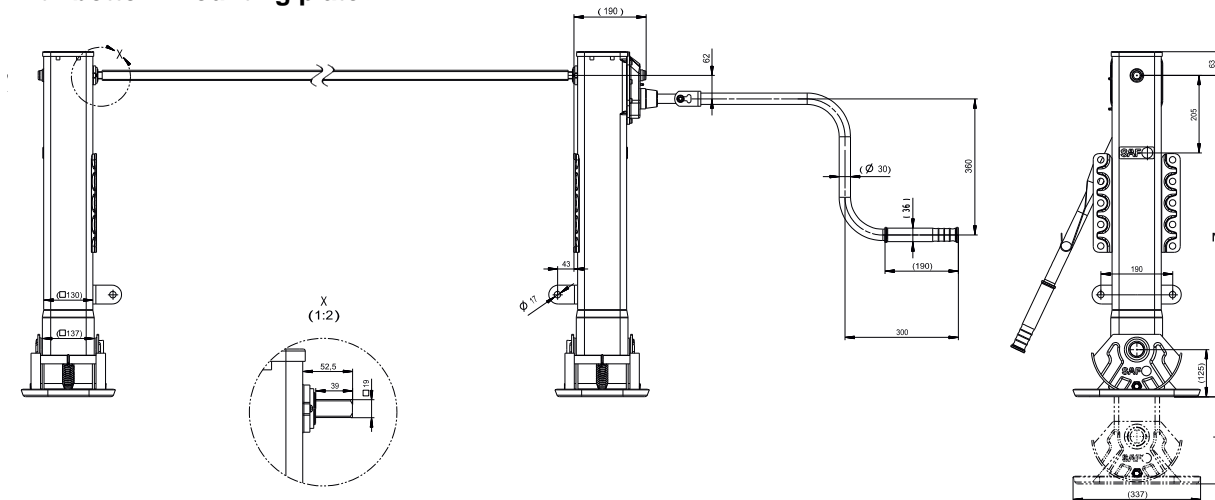

Figure 10

Illustrations with compensating shoe Type S

Hercules "Compact" variants

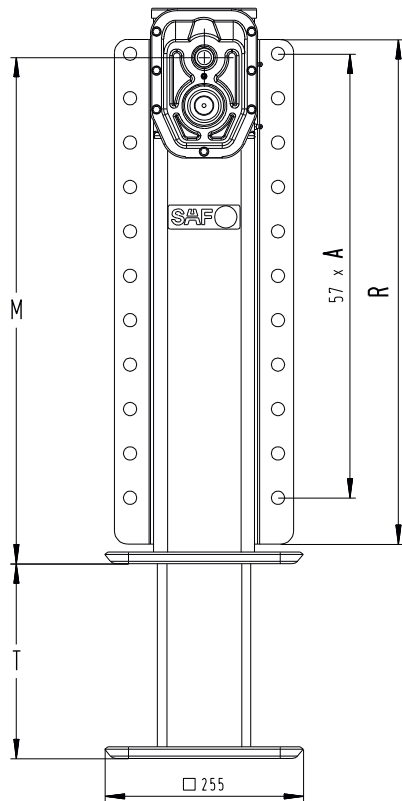

Figure 11

With fixed plate shoe Type D			
M [mm]	T [mm]	A [mm]	R [mm]
650	430	580	648
600	380	530	598
550	330	530	548
500	280	430	498
450	230	380	448

See table 8

Hercules "Compact" mounting plate

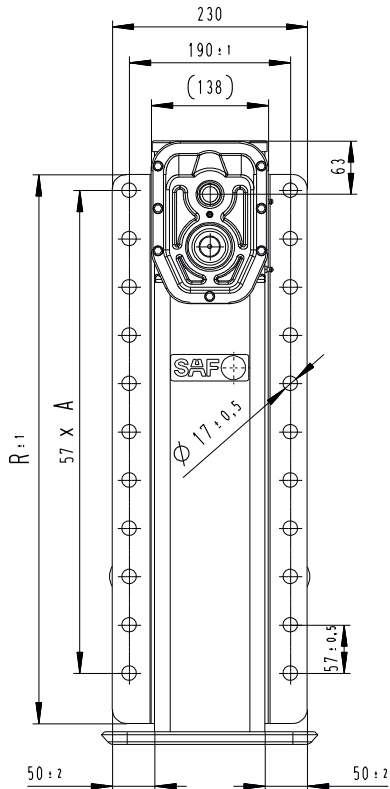

Figure 12

We recommend using M16 (min. strength class 8.8) with washers to screw the mounting plates to the frame of the vehicle. Follow the mounting instructions [Page 27](#).

See [Figure 27-28](#).

This plate allows a large variety of mounting variations.

The clearance towards other components must be assured.

Hercules "Compact" geometric specifications

Landing leg with foot Type D

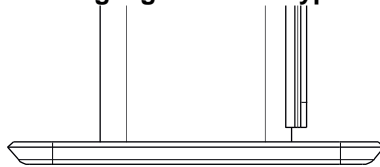

Figure 13

Table 8

Landing leg with the fixed plate shoe Type D / Part number				Mounting height	Travel	Length Mounting plate	Number of holes
with gear (with foot)	Weight [kg]	without gear (with foot)	Weight [kg]	M [mm]	T [mm]	R [mm]	A [mm]
03 389 0180 00	27,3	03 389 0179 00	23,8	450	230	448	8
03 389 0178 00	29,3	03 389 0177 00	25,8	500	280	498	8
03 389 0176 00	31,3	03 389 0175 00	27,8	550	330	548	9
03 389 0174 00	33,7	03 389 0173 00	30,4	600	380	598	9
03 389 0172 00	35,7	03 389 0171 00	32,2	650	430	648	10

Hercules "Compact" installation drawing

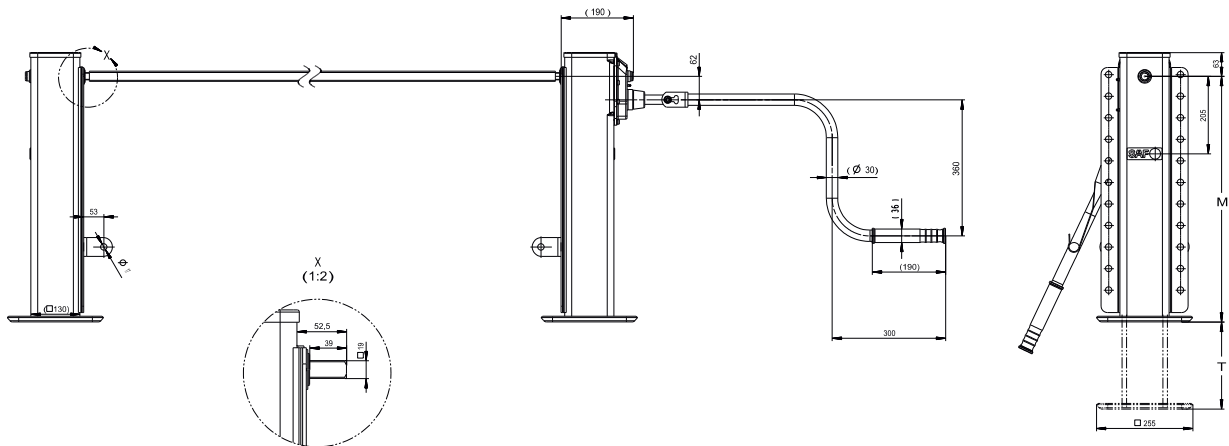

Figure 14

Illustrations with fixed plate shoe Type D

Accessories

Connecting shaft

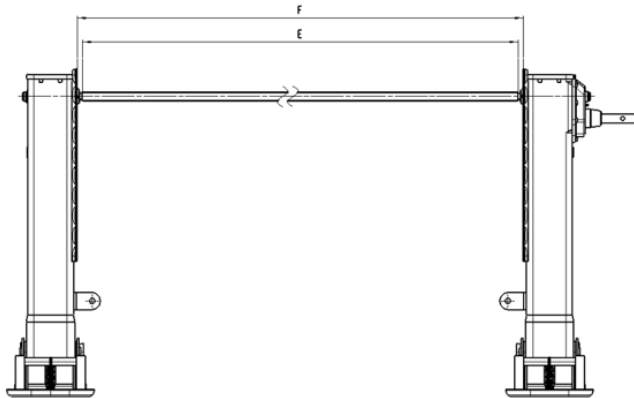

Figure 15



Table 9

Part No.	E [mm]	F [mm]	Weight [kg]
01 435 0022 00	1164	1194	3,3
01 435 0023 00	1340	1370	3,8
01 435 0024 00	1440	1470	4,1
01 435 0025 00	1450	1480	4,1
01 435 0026 00	1470	1500	4,2
01 435 0027 00	1500	1530	4,2
01 435 0028 00	1505	1535	4,4
01 435 0029 00	1575	1605	4,5
01 435 0030 00	1600	1630	4,5
01 435 0031 00	1605	1635	4,6
01 435 0032 00	1635	1665	4,7
01 435 0033 00	1700	1730	4,7
01 435 0034 00	1790	1820	5,0
01 435 0035 00	1800	1830	5
01 435 0036 00	1950	1980	5,3
01 435 0037 00	1425	1455	4
01 435 0038 00	1110	1140	3,2
01 435 0039 00	1535	1565	4,4
01 435 0040 00	1395	1425	4
01 435 0041 00	1570	1600	4,5
	E = F-30		approx. 2,8 kg / m

Crank

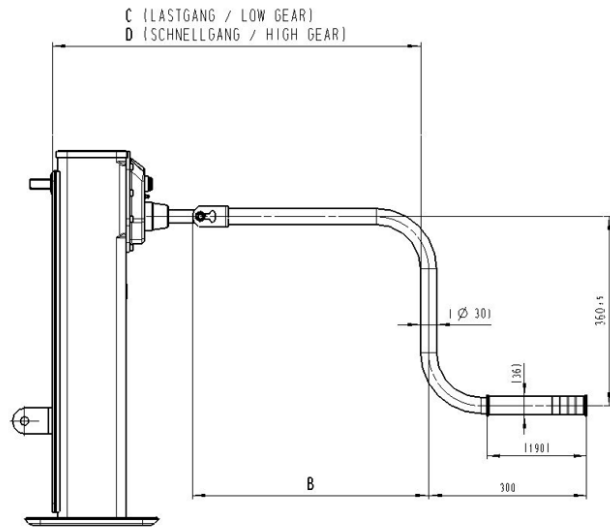

Figure 16

Table 10

Crank			
Part No.	Crank length B [mm]	Low gear C [mm]	Fast gear D [mm]
01 209 0001 00	285	498	514
01 209 0002 00	350	563	579
01 209 0003 00	450	663	679
01 209 0004 00	535	748	764
01 209 0005 00	605	818	834

With the smallest mounting height, low stroke 310 / 350mm and longest crank, please use a suitable crank holder so that the crank is not installed lower than the landing leg. See below **Figure 17**

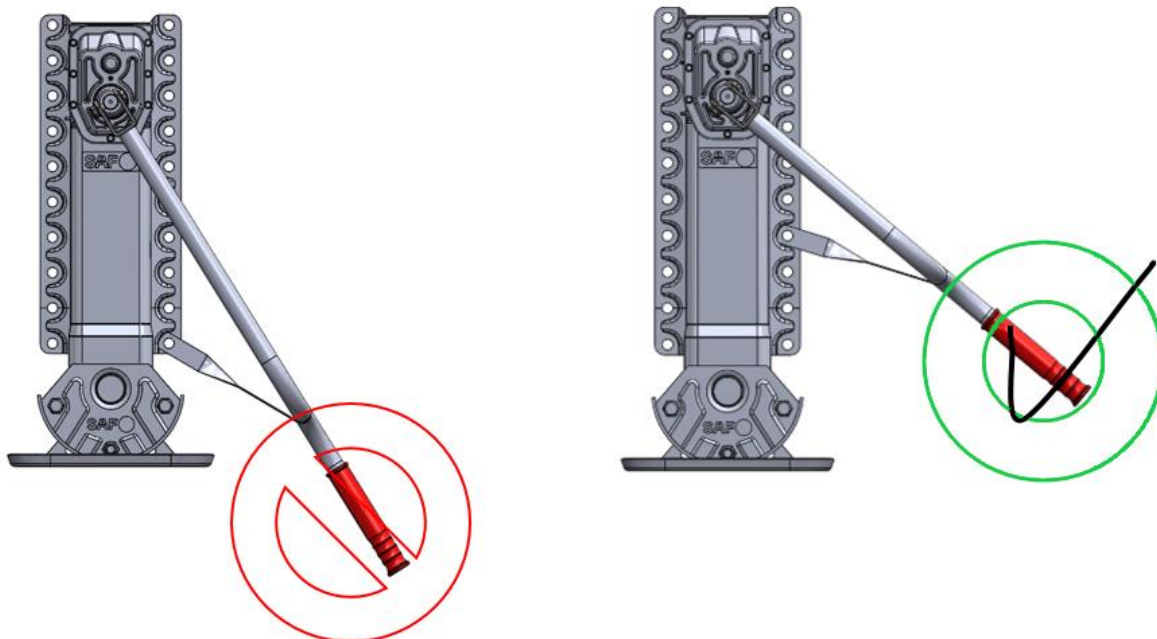

Figure 17

Pay attention to the length of the crank and the position of the crank holder so that the crank is not installed lower than the landing leg. The ground clearance is therefore less.

Crank holder

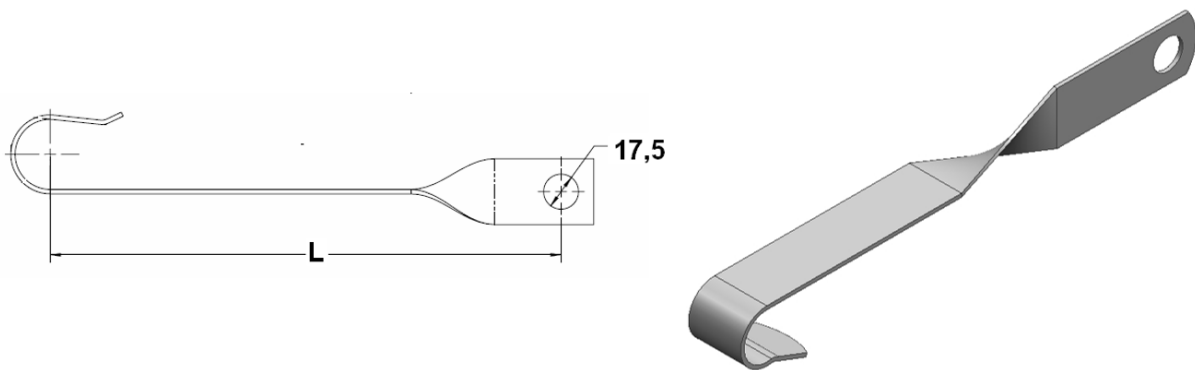

Figure 18

Table 11

Crank holder	
Part No.	L [mm]
01 189 0135 00	260
01 189 0136 00	360

The crank holder is used to hang the crank. This is screwed onto the mounting plate. Depending on the design of the trailer frame, the position of the holder can be determined by the trailer manufacturer. See [Figure 17](#)

Bracket for braces

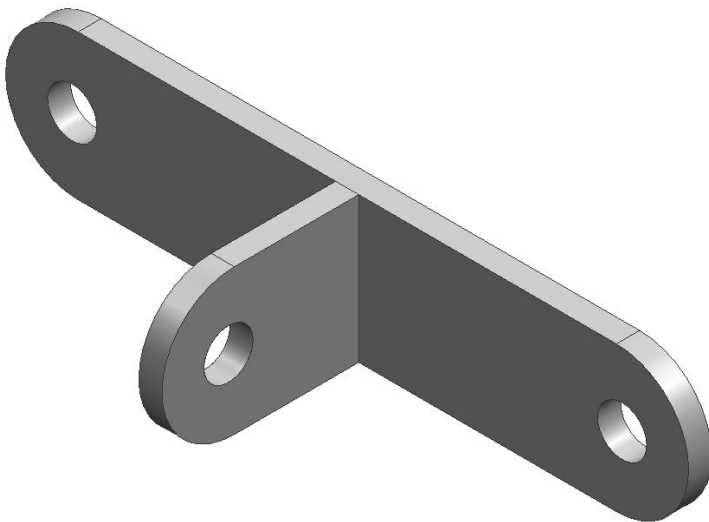

Figure 19

Part number 02 045 0057 00

The bracket serves to brace the support laterally, transversely and diagonally. See [Page 17-18](#).

Hercules "drawbar support / swivel support" variants

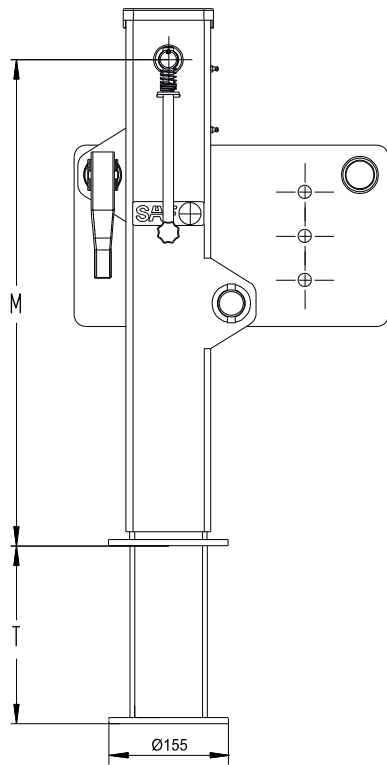

Figure 20

With fixed plate shoe Type D	
M [mm]	T [mm]
630	400
580	350
530	300
480	250
430	200

See table 12

Special technical feature

- For attachment to the drawbar of a tandem trailer.
- Compact design and a large stroke together with a low installation height.
- Generous ground clearance by swiveling the support.

Hercules "drawbar support / swivel support" mounting plate

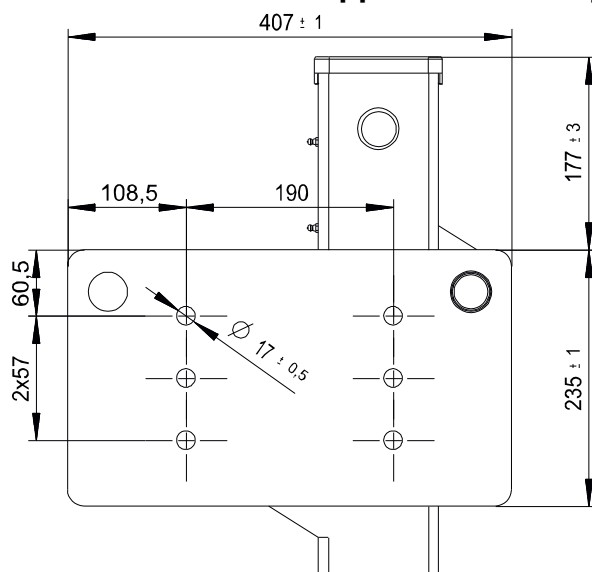

Figure 21

We recommend using M16 (min. strength class 8.8) with washers to screw the mounting plates to the frame of the vehicle.

The clearance towards other components must be assured.

Hercules "drawbar support / swivel support" geometric specifications

Landing legs with foot Type D

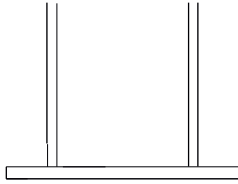

Figure 22

Table 12

Landing leg with fixed plate shoe Type D / Part number		Mounting height	Travel	TYPE
with gear unit (with foot)	Weight [kg]	M [mm]	T [mm]	LGHD .. S D [mm]
03 389 0180 00	29	430	200	43 - 20
03 389 0178 00	30,5	480	250	48 - 25
03 389 0176 00	32	530	300	53 - 30
03 389 0182 00	33,5	580	350	58 - 35
03 389 0181 00	35	630	400	63 - 40

Hercules "drawbar support / swivel support" installation drawing

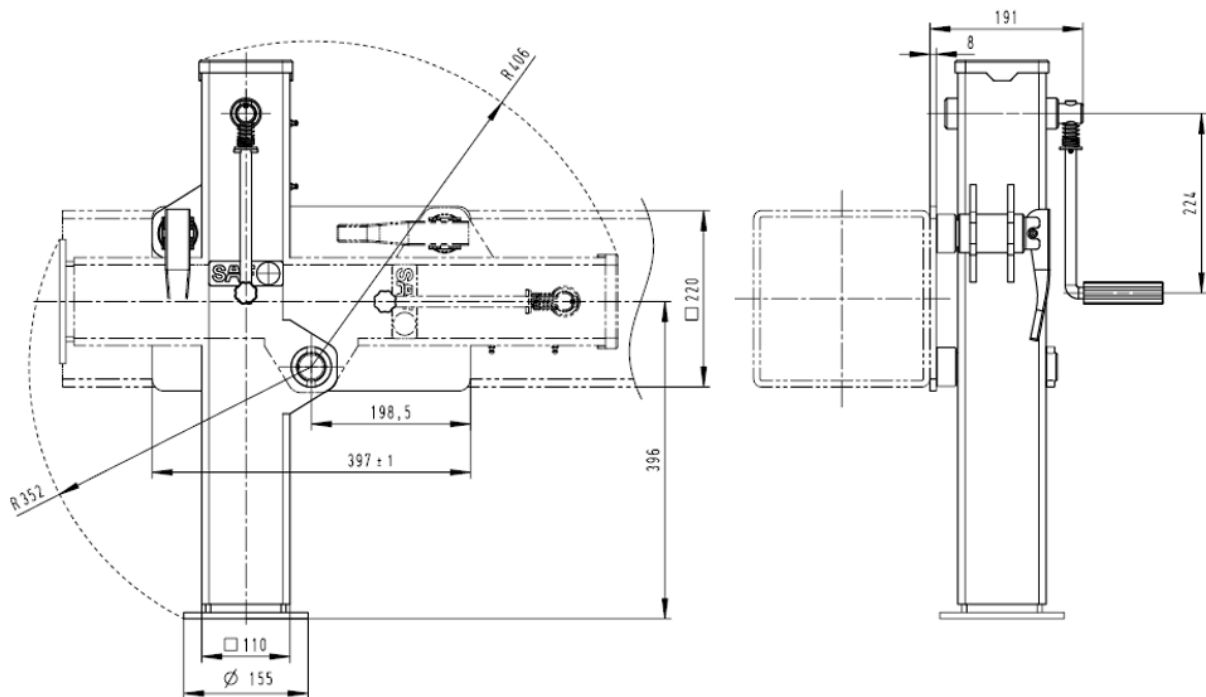

Figure 23

Illustrations with fixed plate shoe Type D

Drop leg variant

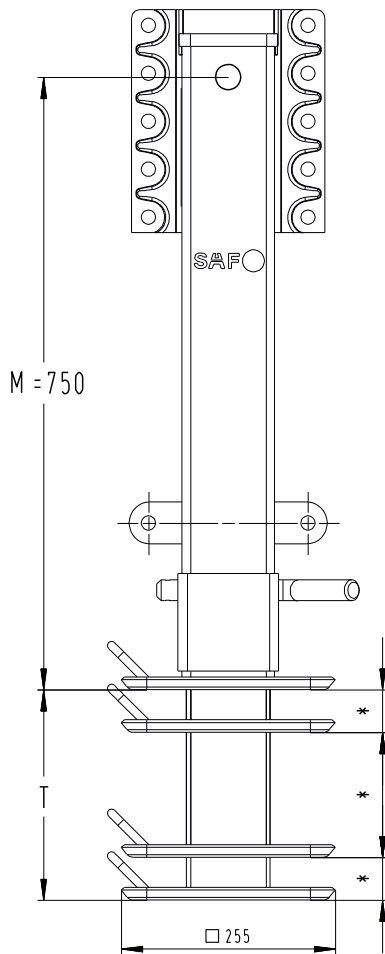

Figure 24

With fixed plate shoe Type D	
M [mm]	T [mm]
750	*first travel step 50.8 **second travel step 21x25.4 ***third travel step 50.8 Total travel 635

See table 13

Special technical feature

- The drop is variable over several steps and can be adjusted precisely.
- Simple height adjustment of the foot.
- Suitable for all trailers (not suitable for ferrying).
- Two drop legs must be installed per vehicle.
- Side securing position
- Fixed plate shoe type D

Drop leg mounting plate

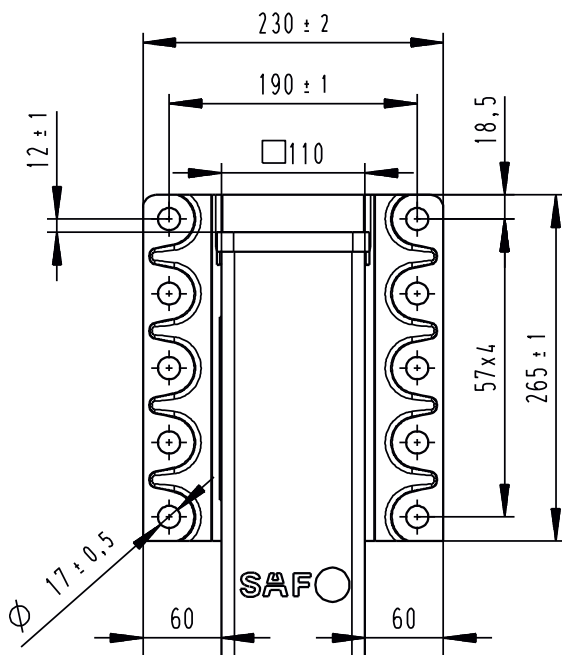

Figure 25

We recommend using M16 (min. strength class 8.8) with washers to screw the mounting plates to the frame of the vehicle. Follow the mounting instructions [Page 27](#).

See [Figure 27-28](#).

This mounting plate allows a large variety of mounting variations.

The clearance towards other components must be assured.

Drop leg geometric specifications

Support leg with foot Type D

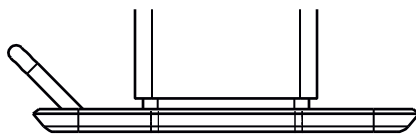

Figure 26

Table 13

Landing leg with fixed plate shoe Type D / Part number		Mounting height	Travel	TYPE
with gear unit (with foot)	Weight [kg]	M [mm]	T [mm]	LGDL ..- .. T D [mm]
03 389 0165 00	25	750	630	75 - 63

Selection

Important:

The following characteristics must be taken into account when selecting the landing gear.

- Installation space
- Ground clearance
- Stroke and load

Consider the support foot [Page 10](#) for the corresponding task
Consider the possible semi-trailer loads

Only use supports of the same series in one set, right hand and left hand.

Support mounting instructions

- Fully retract the supports as far as they will go.
- Align the supports vertically to the frame of the trailer.
- Align the supports parallel to each other.
- Check the length of the connecting shaft (E) and adapt if necessary. See [Table 9 Page 17](#).
- Insert the connecting shaft (E). Maintain a play of 5 ± 3 mm.
- Secure the bracing of the support device at an angle of 45° as shown in [Figure 28-29](#).
- Tightening torque of 190 Nm for the M16 screws.

Crank mounting instructions

- The crank is mounted with a M10 8.8 screw only with a tightening torque of 25 Nm.
- The crank must rotate freely on the outer contour of the vehicle without creating a crush hazard.
- Note the shifting travel between fast gear and low gear. * (dimension C is decisive here)
- The crank must be secured in a crank holder while driving.
- Choose the correct length of the crank holder.

After mounting, carry out the following test for operational safety.

Unhook and attach the crank.

Push in or pull out to switch to the low gear and back to fast gear.

Extend the two supports in fast gear until they touch the ground, checking that they touch the ground at the same time.

Push the crank into the low gear and raise the vehicle.

Relieve the crank slowly, avoiding possible crank kickback.

Hang the crank securely in the crank holder.

After a successful function check, move the landing gear back to the starting position.

Mounting instructions

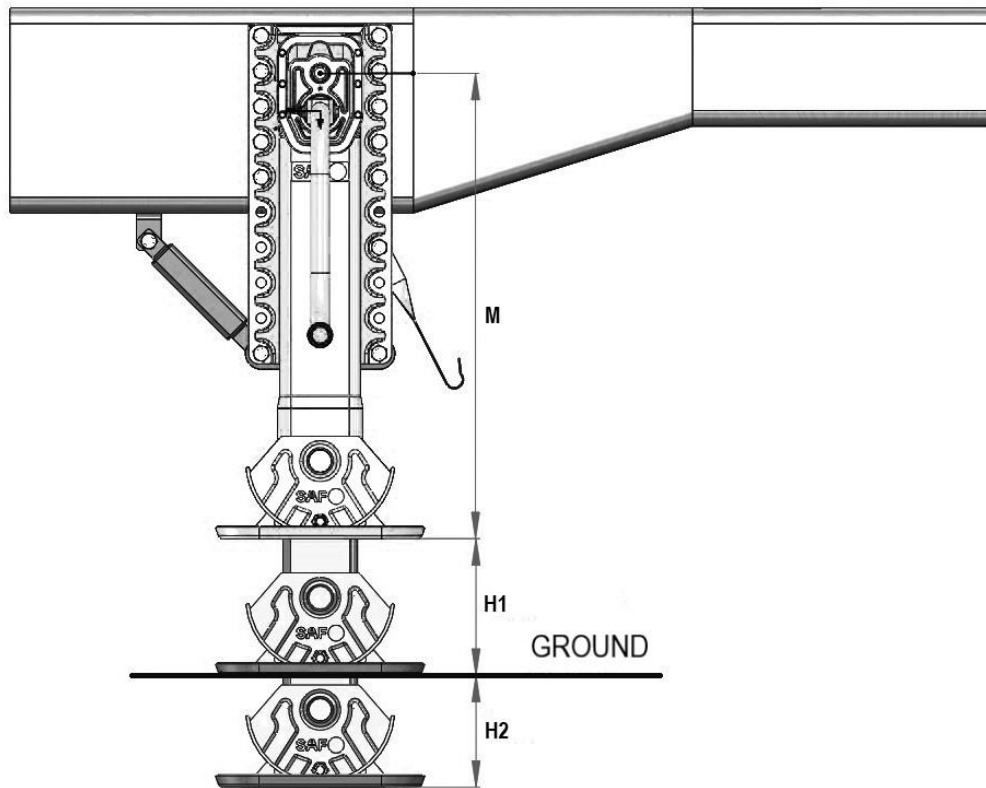

Figure 27

M = Mounting height

H1 = Ground clearance min. 250 mm

H2 = Stroke reserve min approx. 120 mm

At installation, make sure that both support legs touch the ground at the same time when the landing gear is extended. A different load on the supports will damage them and possibly cause them to fail.

Note the clearances for the ISO 1726 tractor unit.

Mounting tolerances

Pay attention to the flatness of the mounting surface and the position of the output shaft.

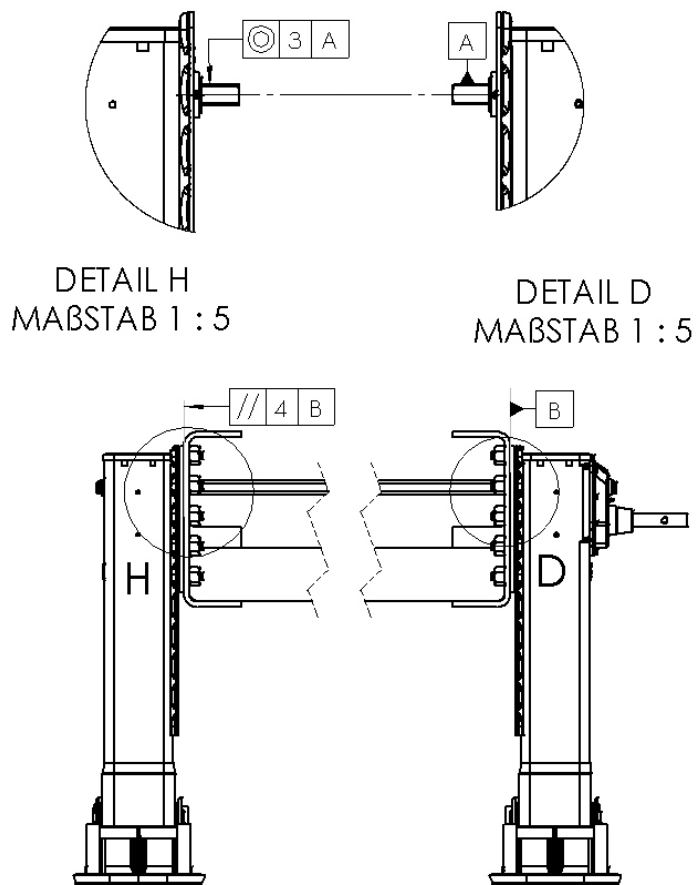
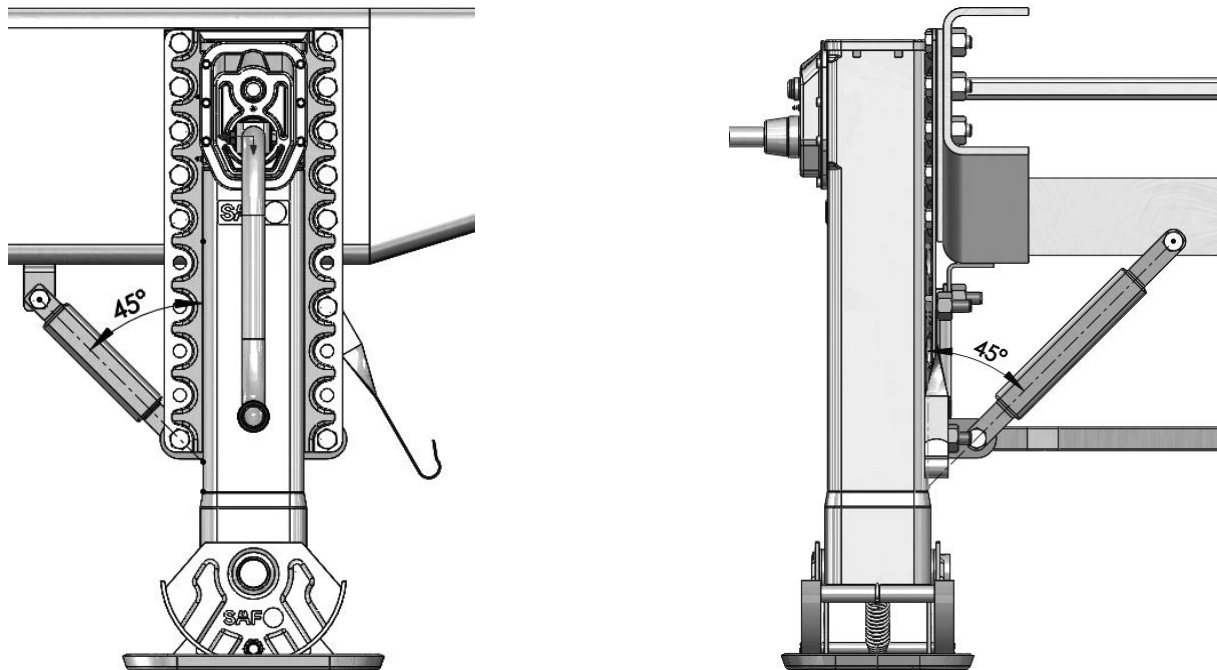

Figure 28

Pay attention to the tolerance of parallelism and concentricity, otherwise the function of the connecting shaft will be restricted. The connecting shaft cannot be tilted. Difficulty in turning the connecting shaft are a sign of incorrect assembly, or incorrect selection of the tolerances.

Bracing**Figure 29**

The landing gear must be braced in such a way that the forces are optimally introduced into the chassis.

Material required for bolting (per support):

- At least 10 M16 hexagon bolts 8.8, length according to the vehicle frame
- At least 10 hexagon nuts M16
- At least 10 washers

If the landing gear cannot be fastened with 10 bolts, it must always be bolted with the max. bolt spacing.

A bracing angle of 45 ° is recommended in order to optimally transfer the forces into the chassis. See Figure 29.

Installation instructions

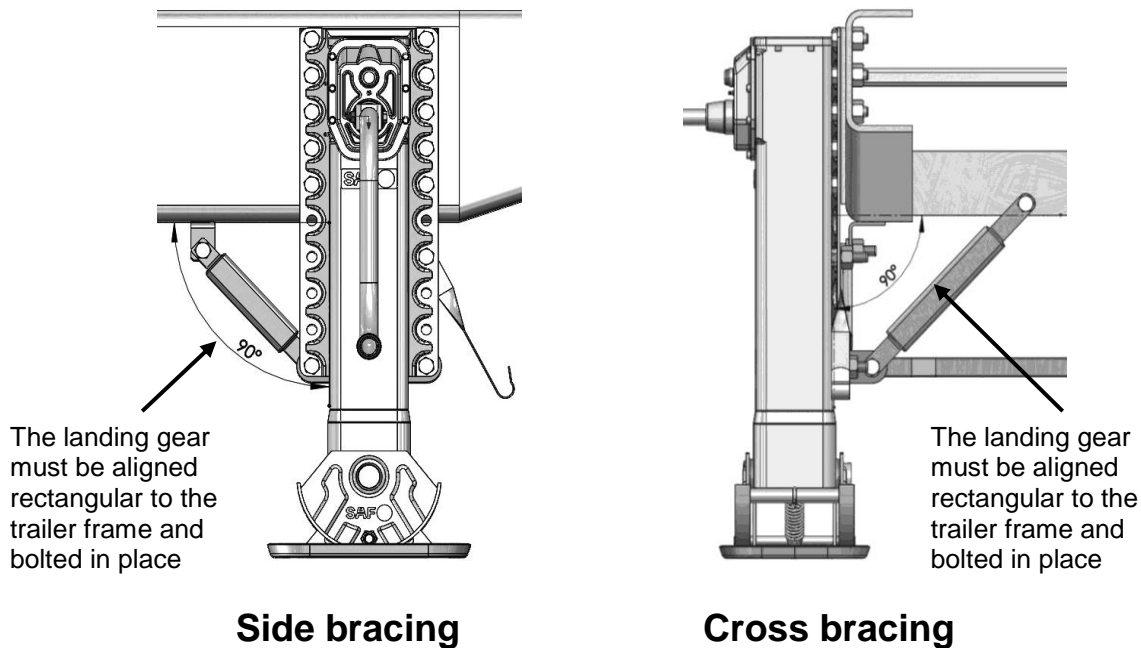

Figure 30

- Select the required landing gear according to the installation and coupling height of the trailer.
- The min. ground clearance is 250mm. Pay attention to the stroke reserve of the fifth wheel. See [Figure 27](#).
- Select the corresponding connecting shaft. See [Table 9](#), the play may be 5+/-3 mm here.
- Select the corresponding crank, see [Table 10](#), and pay attention to the crank length. See [Figure 17](#).
- The landing gear and the bracing are secured to the frame using hexagon bolts with a M16 thread. The tightening torque is approx. 190 Nm. Adjust the length of the bolts according to the trailer frame.
- Align the support rectangular in length and cross direction to the trailer frame.
- Observe the required clearance when installing the connecting shaft.
- Check the extension and retraction of the landing gear and the changeover in fast gear and low gear.
- The support feet must reach the ground at the same time to provide straight support.

Surface coating information

Corrosion protection

- Landing gear with powder coating, black color RAL 9005

Powder coating

- Can be painted over with all standard 1K and 2K top coats
- Corrosion protection min. 504 hours salt spray test according to DIN 50021

Operation

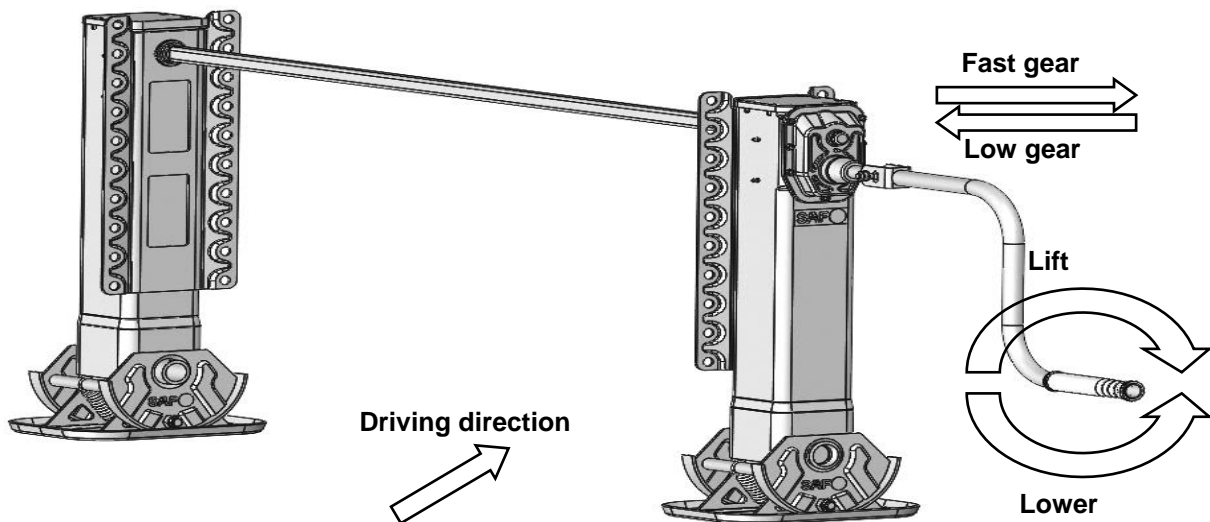

Figure 31

- Push the crank inwards to change over to low gear
- Pull the crank outwards to change over to fast gear
- Rotate the crank clockwise to extend the support.
- Rotate the crank counter-clockwise to retract the support.

At a glance

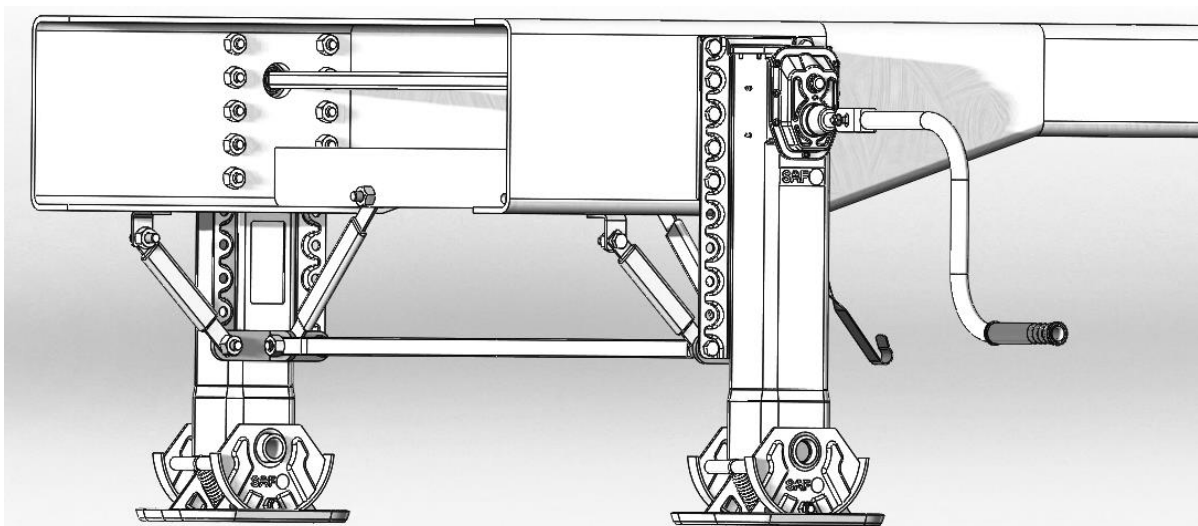

Figure 32