

# HOLLAND FIFTH WHEEL SLIDER

FOR OPERATIONS  
WHICH MAY  
REQUIRE FREQUENT  
ADJUSTMENT.

*Integrated Light Weight  
Slider System (ILS)*



*Heavy Duty Slider*



# FIFTH WHEEL SLIDER

## THE INDUSTRY STANDARD FIFTH WHEEL SLIDER ASSEMBLY IS NOW EVEN BETTER

with the option of our lightweight or the new addition of a heavy duty slider. The air release slide mechanism provides convenience if frequent adjustments are required.

The selection of a sliding fifth wheel provides the capability to transfer weight between truck axles, accommodate trailers with different kingpin settings and vary vehicle combination lengths.

Driver comfort is increased as the fifth wheel is located closer to the centreline of the bogie or rear axle. When the axles are not overloaded, the driver has the ability to extend the unit for maximum comfort. A sliding fifth wheel positioned forward provides the additional manoeuvrability in tight locations and sliding the fifth wheel rearward accommodates trailers with short landing gear clearance.

### HEAVY DUTY SLIDER

#### CAPACITY

- 700 mm Travel
- 270 kN D-Value
- 2400 mm Long
- 1100 mm Wide
- Weight = 315 kg

#### WARRANTY:

- 12 Months Materials and Workmanship Warranty

Designed for operating conditions, applications and loads which may require greater capacities than standard fifth wheels.

Predrilled to suit standard and narrow chassis.

Suitable for Holland's Heavy Duty FW70 or FW72 LowLube™ Fifth Wheels.

Available for mounting of fixed or ballrace assemblies.

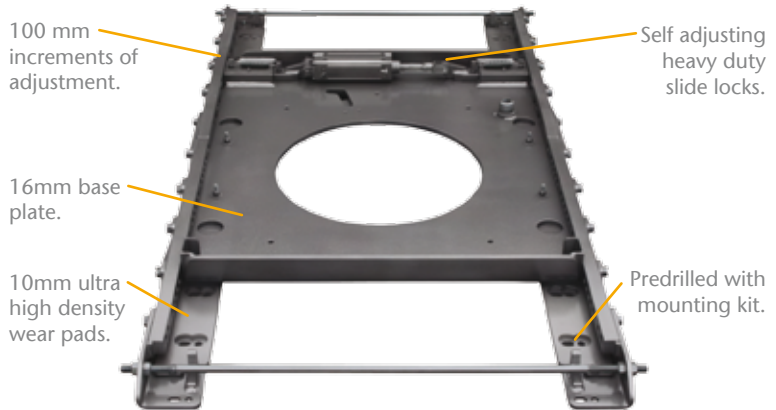

Low 40mm base plate height.

Note: Refer to Holland Fifth Wheel Catalogue for overall height of your nominated assembly. Then deduct the base plate thickness from the assembly height and add 40mm for the slider. This will give you an overall height for a fifth wheel assembly and slider combination.

### LIGHT WEIGHT SLIDER (ILS)

#### CAPACITY

- 610 mm and 915 mm Travel
- 151 kN D-Value
- 1135 mm and 1440 mm Base Lengths
- 1050 mm Wide

#### WARRANTY:

- 12 Months Materials and Workmanship Warranty

Designed for standard operating conditions and applications.

Suitable for Holland's pro-hitch FW351 or FW342 LowLube™ Fifth Wheels.

Available in fixed only mounting.

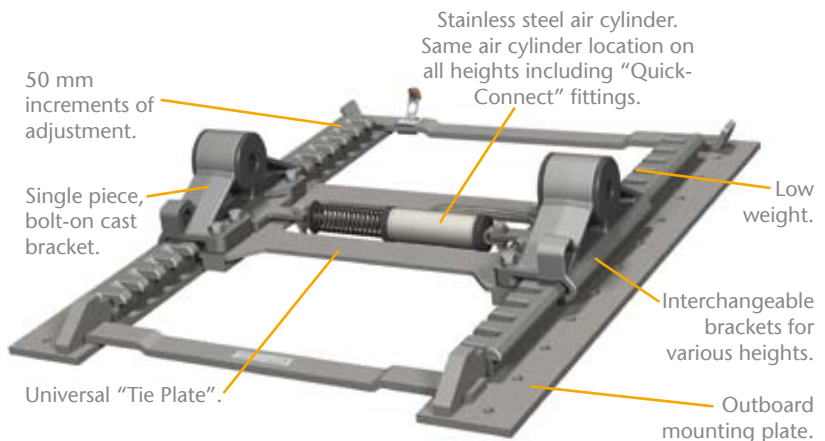

Standard height 173mm  
198 mm & 224 mm available on request.

FW21-32 Rev A 0408 Amendments and errors reserved. © SAF-HOLLAND (Aust.) Pty. Ltd.

SAF-HOLLAND (Aust.) Pty. Ltd. · PO Box 63 · 115 High St · Melton Vic 3337  
Tel: (03) 9743 6799 Fax: (03) 9743 6763

Western Australia ·	Tel: (08) 9353 6122	Fax: (08) 9353 6144
Queensland ·	Tel: (07) 3375 7033	Fax: (07) 3375 7044
New South Wales ·	Tel: (02) 9672 1950	Fax: (02) 9672 1994
South Australia ·	Tel: (08) 8345 1546	Fax: (08) 8345 0985

www.safholland.com.au

