

Holland



GO THE DISTANCE.

Holla

TABLE OF CONTENTS

SECTION 1

FIFTH WHEELS

- Quick Reference Guide 1
- Pro-hitch 351 2
- FW342 3
- FW70 4
- FW72 5
- Kompensator 6
- Ballrace 7
- Special Application 8
- Parts 8

SECTION 2

KINGPINS

- Replaceable / Weld-in & Accessories 1

SECTION 3

COUPLING

- Pintle Hooks 1
- Drawbars 2

SECTION 4

LANDING GEAR

- MarkV 1
- LG5000 2
- Light Commercial 3
- Parts 4

SECTION 5

TRAILER SUSPENSION

- Holland Air 1
- Neway 2
- Parts 3

SECTION 6

TRUCK SUSPENSION

- Single 1
- Tandem 2
- Tridem 3
- Parts 4

CONDITIONS OF SALE

WARRANTY



GO THE DISTANCE.

FW342



KOMPENSATOR

FW70









**HD
SLIDER**

FIFTH WHEELS

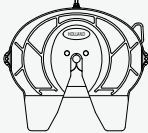
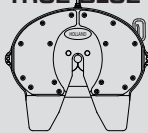
SECTION 1

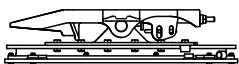
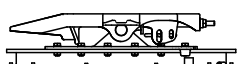
- Quick Reference Guide	
- Pro-hitch 351	1
- FW342	2
- FW70	3
- FW72	4
- Kompensator	5
- Ballrace	6
- Special Application	7
- Parts	8

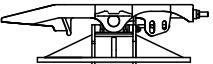
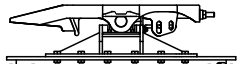
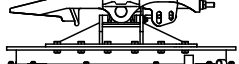
QUICK REFERENCE GUIDE

 GO THE DISTANCE. SELECTION GUIDE VIC: 03 9743 6799 FAX: 03 9743 6763 WA: 08 9353 6122 FAX: 08 9353 6144 QLD: 07 3375 7033 FAX: 07 3375 7044 NSW: 02 9672 1950 FAX: 02 9672 1994		PRO-HITCH351 	LO-LUBE342 TRUE BLUE 
		General B-Double Tanker Tipper Skells	General B-Double Tanker Tipper Dedicated Combinations
BASE OPTIONS	HEIGHT		
Fixed 	159mm	FW351L2	
	181mm	FW351T2	
	204mm	FW351F2	
	214mm	FW351A2	
	249mm	FW351X2	
	169mm		FW342L2
	191mm		FW342T2
	214mm		FW342F2
	224mm		FW342A2
	259mm		FW342X2
Note: 20mm base plate options available. Replace suffix "2" with "3" (eg. FW351L2 becomes FW351L3)			
Single Row Ballrace 	231mm	FW351LS4	
	253mm	FW351TS4	
	286mm	FW351AS4	
	241mm		FW342LS4
	263mm		FW342TS4
	296mm		FW342AS4
Double Row Ballrace 	261mm	FW351LD4	
	283mm	FW351TD4	
	316mm	FW351AD4	
	271mm		FW342LD4
	293mm		FW342TD4
	326mm		FW342AD4
Note: 20mm base plate options available. Replace suffix "4" with "5" (eg. FW351LD4 becomes FW351LD5)			
Kompensator (Wing) 	240mm	FW351K	
	250mm		FW342K
Kompensator (Plate) 	244mm	FW351KP6	
	254mm		FW342KP6
Note: 20mm base plate options available. Replace suffix "6" with "7" (eg. FW351KP6 becomes FW351KP7)			
Kompensator Single Row Ballrace 	301mm	FW351KS4	
	311mm		FW342KS4
Kompensator Double Row Ballrace 	331mm	FW351KD4	
	341mm		FW342KD4
Note: 20mm base plate options available. Replace suffix "4" with "5" (eg. FW351KS4 becomes FW351KS5)			
Slider 	170mm	FW35097702	
	180mm		FW34097702

QUICK REFERENCE GUIDE

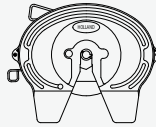
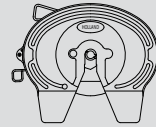
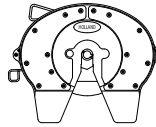
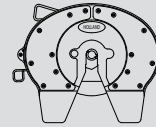
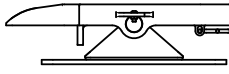
 <p>SELECTION GUIDE</p> <p>VIC: 03 9743 6799 FAX: 03 9743 6763</p> <p>WA: 08 9353 6122 FAX: 08 9353 6144</p> <p>QLD: 07 3375 7033 FAX: 07 3375 7044</p> <p>NSW: 02 9672 1950 FAX: 02 9672 1994</p> <p>BASE OPTIONS HEIGHT</p>		FW70D 50MM 	FW70O 90MM 	FW72D 50MM LO-LUBE 	FW72O 90MM LO-LUBE 
		Low Loaders Road Train Live Stock Off-Road Float	Low Loaders Road Train Live Stock Off-Road Float	Low Loaders Road Train Live Stock Off-Road Float	Low Loaders Road Train Live Stock Off-Road Float
Fixed 	159mm 181mm 204mm 214mm 249mm	FW70DL2 FW70DT2 FW70DF2 FW70DA2 FW70DX2	FW70OL2 FW70OT2 FW70OF2 FW70OA2 FW70OX2		
	162mm 184mm 208mm 218mm 252mm			FW72DL2 FW72DT2 FW72DF2 FW72DA2 FW72DX2	FW72OL2 FW72OT2 FW72OF2 FW72OA2 FW72OX2

Note: 20mm base plate options available. Replace suffix "2" with "3" (eg. FW70DL2 becomes FW70DL3)

Single Row Ballrace 	231mm 253mm 286mm	FW70DLS4 FW70DTS4 FW70DAS4	FW70OLS4 FW70OTS4 FW70OAS4		
	234mm 256mm 289mm			FW72DLS4 FW72DTS4 FW72DAS4	FW72OLS4 FW72OTS4 FW72OAS4
Double Row Ballrace 	261mm 283mm 316mm	FW70DLD4 FW70DTD4 FW70DAD4	FW70OLD4 FW70OTD4 FW70OAD4		
	264mm 286mm 319mm			FW72DLD4 FW72DTD4 FW72DAD4	FW72OLD4 FW72OTD4 FW72OAD4

Note: 20mm base plate options available. Replace suffix "4" with "5" (eg. FW70DLD4 becomes FW70DLD5)

Kompensator (Wing) 	240mm	FW70DK	FW70OK		
	243mm			FW72DK	FW72OK
Kompensator (Plate) 	244mm	FW70DKP6	FW70OKP6		
	247mm			FW72DKP6	FW72OKP6

Note: 20mm base plate options available. Replace suffix "6" with "7" (eg. FW70DKP6 becomes FW70DKP7)

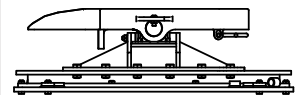
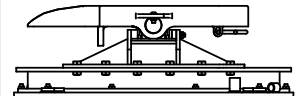
Kompensator Single Row Ballrace 	301mm	FW70DKS4	FW70OKS4		
	304mm			FW72DKS4	FW72OKS4
Kompensator Double Row Ballrace 	331mm	FW70DKD4	FW70OKD4		
	334mm			FW72DKD4	FW72OKD4

Note: 20mm base plate options available. Replace suffix "4" with "5" (eg. FW70DKS4 becomes FW70DKS5)

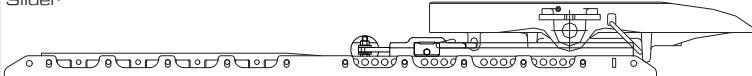
Slider 	Contact Holland to discuss your specific Heavy Duty FW70 Sliding Fifth Wheel requirements.			
---	--	--	--	--

Note: All FW70 & FW72 Fifth Wheel assemblies are supplied in LH Release as standard.
 RH Release is available, use the suffix "R" when ordering this option. ie: FW70DT2 becomes FW70DT2R.



GO THE DISTANCE.

PRO-HITCH 351

Pro-hitch 351
Cast Fifth Wheel Assemblies

D Rating: 50/165 kN

The worlds most popular fifth wheel.
Suitable for general freight, tippers,
B-doubles, tankers and
all applications up to 165 kN.

*Note: Not suitable for livestock.



GO THE DISTANCE.

FIFTH WHEELS

pro-hitch 351 Cast Fifth Wheels

CAST STEEL Construction to suit 50mm Kingpin.

All Fifth Wheel packages: Tested to AS4968 series under requirements of ADR 62/01

pro-hitch351 D rating: 50/165

As configurations can change, please refer to the respective assembly or part no. for the correct & applicable D rating.

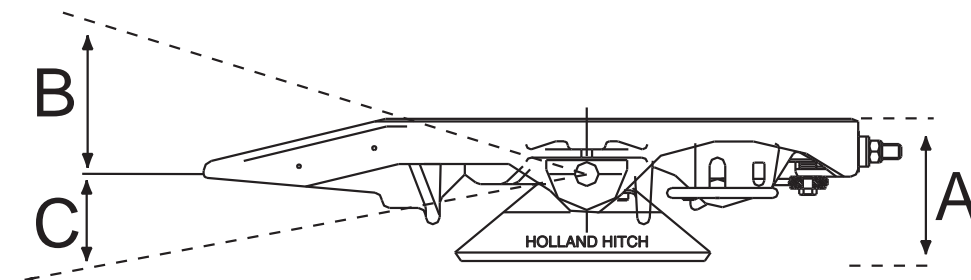

Part Number	Height (A)	Assembly Weight	Oscillation		D-Rating kN	CRN Number
			B	C		
*XA351A	-	110 kg	Top Only		50/165	N/A
**FW351L	143 mm	123 kg	10 deg	8 deg	50/165	16754
**FW351T	165 mm	128 kg	15 deg	12 deg	50/165	16754
FW351F	188 mm	130 kg	18 deg	16 deg	50/165	16754
FW351A	198 mm	131 kg	21 deg	18 deg	50/165	16754
FW351X	233 mm	136 kg	29 deg	23 deg	50/165	16754

* Top plate only -c/w foot pins & fixings.

** Restricted Angle of Pitch - Base plate must have cut outs to allow for the minimum 8 degrees fore & aft oscillation.

Note: All FW351 cast fifth wheels complete with feet are now using a cast steel weld on type foot.

Not suitable for livestock



GO THE DISTANCE.

FIFTH WHEELS

pro-hitch 351 Cast Fifth Wheels On A Base Plate

Section 1 - 1b

CAST STEEL Construction to suit 50mm Kingpin.

All Fifth Wheel packages: Tested to AS4968 series under requirements of ADR 62/01

pro-hitch351 D rating: 50/165

As configurations can change, please refer to the respective assembly or part no. for the correct & applicable D rating.

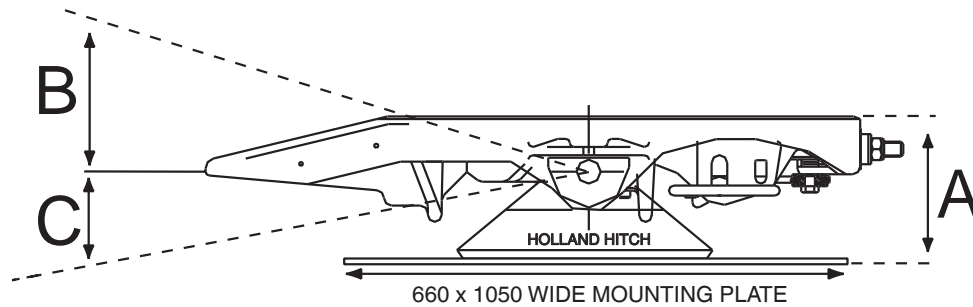

Part Number	Height (A)	Base Plate Thickness	Assembly Weight	Oscillation		D-Rating kN	CRN Number
				B	C		
*FW351L2	159 mm	16 mm	214 kg	10 deg	8 deg	50/165	16626
*FW351L3	163 mm	20 mm	241 kg	10 deg	8 deg	50/165	16626
*FW351T2	181 mm	16 mm	220 kg	15 deg	12 deg	50/165	16626
*FW351T3	185 mm	20 mm	246 kg	15 deg	12 deg	50/165	16626
FW351F2	204 mm	16 mm	222 kg	18 deg	16 deg	50/165	16626
FW351F3	208 mm	20 mm	248 kg	18 deg	16 deg	50/165	16626
FW351A2	214 mm	16 mm	223 kg	21 deg	18 deg	50/165	16626
FW351A3	218 mm	20 mm	249 kg	21 deg	18 deg	50/165	16626
FW351X2	249 mm	16 mm	227 kg	29 deg	23 deg	50/165	16626
FW351X3	253 mm	20 mm	254 kg	29 deg	23 deg	50/165	16626

* Restricted Angle of Pitch - Base plate must have cut outs to allow for the minimum 8 degrees fore & aft oscillation.

Note: Specifications regarding heights and weights are nominal only. We reserve the right to make changes as necessary.

Not suitable for livestock



FIFTH WHEELS

pro-hitch 351 Cast Fifth Wheels On A Single Row Ballrace Assembly

CAST STEEL Construction to suit 50mm Kingpin.

All Fifth Wheel packages: Tested to AS4968 series under requirements of ADR 62/01

pro-hitch351 D rating: 50/165

As configurations can change, please refer to the respective assembly or part no. for the correct & applicable D rating.

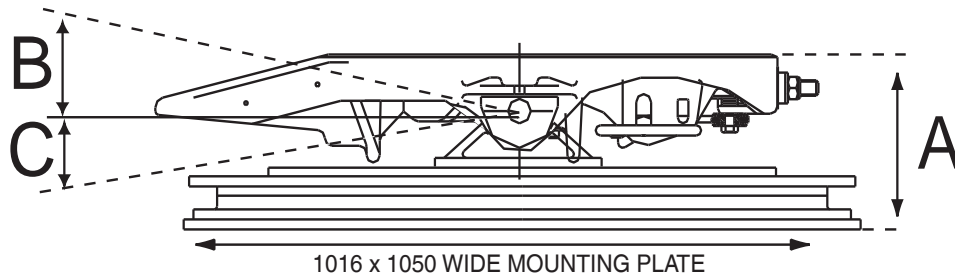

Part Number	Height (A)	Base Plate Thickness	Assembly Weight	Oscillation		D-Rating kN	CRN Number
				B	C		
FW351LS4	231 mm	16 mm	319 kg	13 deg	9 deg	50/165	16641
FW351TS4	253 mm	16 mm	320 kg	13 deg	12 deg	50/165	16641
FW351AS4	286 mm	16 mm	323 kg	17 deg	12 deg	50/165	16641

pro-hitch 351 Cast Fifth Wheels On A Double Row Ballrace Assembly

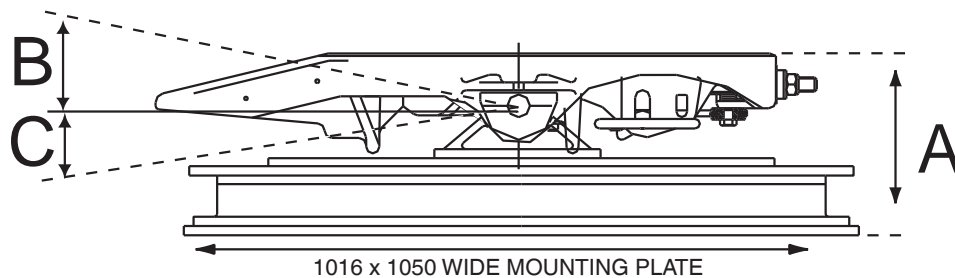

Part Number	Height (A)	Base Plate Thickness	Assembly Weight	Oscillation		D-Rating kN	CRN Number
				B	C		
FW351LD4	261 mm	16 mm	340 kg	13 deg	9 deg	50/165	16627
FW351TD4	283 mm	16 mm	341 kg	17 deg	12 deg	50/165	16627
FW351AD4	316 mm	16 mm	344 kg	17 deg	12 deg	50/165	16627

Note: 'S' Suffix in part number = Single row ball race.

'D' Suffix in part number = Double row ball race.

Specifications regarding heights and weights are nominal only. We reserve the right to make changes as necessary.

Not suitable for livestock



GO THE DISTANCE.

FIFTH WHEELS

pro-hitch 351 Cast Fifth Wheels On A Kompensator

Section 1 - 1d

CAST STEEL Construction to suit 50mm Kingpin.

All Fifth Wheel packages: Tested to AS4968 series under requirements of ADR 62/01

pro-hitch351 D rating: 50/165

As configurations can change, please refer to the respective assembly or part no. for the correct & applicable D rating.

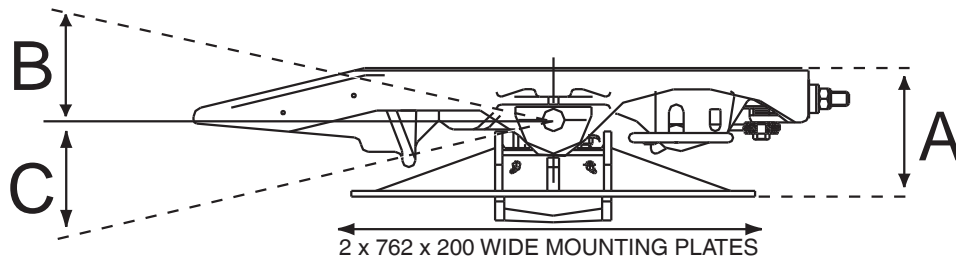

Part Number	Height (A)	Base Plate Thickness	Assembly Weight	Oscillation		D-Rating kN	CRN Number
				B	C		
FW351K	240 mm	12 mm	241 kg	23 deg	23 deg	50/163	16639

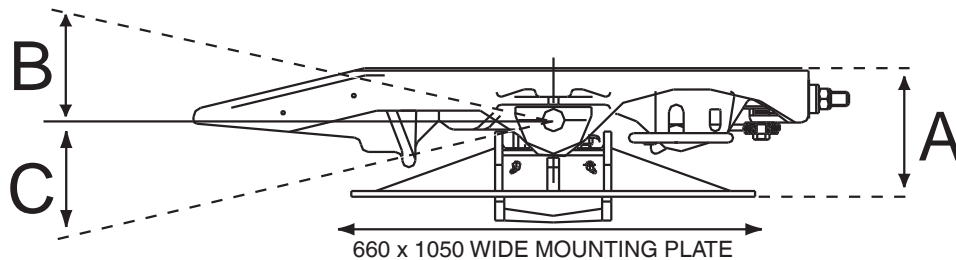

Part Number	Height (A)	Base Plate Thickness	Assembly Weight	Oscillation		D-Rating kN	CRN Number
				B	C		
FW351KP	240 mm	12 mm	265 kg	23 deg	23 deg	50/163	16637
FW351KP6	244 mm	16 mm	282 kg	23 deg	23 deg	50/163	16637
FW351KP7	248 mm	20 mm	299 kg	23 deg	23 deg	50/163	16637

Note: Kompensator Allows 5 degree of oscillation either side of vertical centre line. Centre of gravity not to exceed 1120mm above Fifth Wheel Top Plate Surface.

Specifications regarding heights and weights are nominal only. We reserve the right to make changes as necessary.

Not suitable for livestock



FIFTH WHEELS

pro-hitch 351 Cast Fifth Wheels On A Single Row Ballrace/Kompensator

CAST STEEL Construction to suit 50mm Kingpin.

All Fifth Wheel packages: Tested to AS4968 series under requirements of ADR 62/01

pro-hitch351 D rating: 50/165

As configurations can change, please refer to the respective assembly or part no. for the correct & applicable D rating.

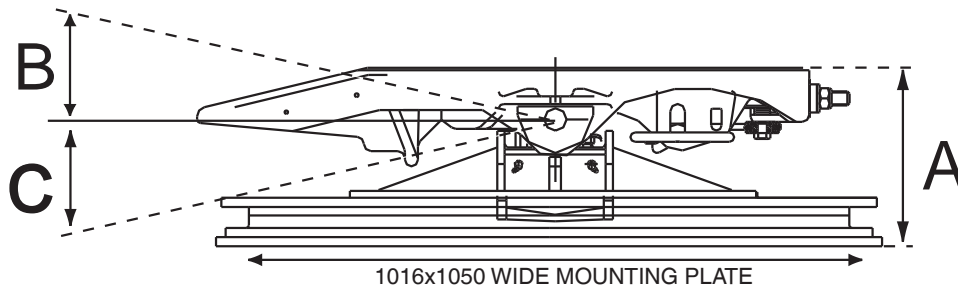

Part Number	Height (A)	Base Plate Thickness	Assembly Weight	Oscillation		D-Rating kN	CRN Number
				B	C		
FW351KS4	301 mm	16 mm	397 kg	19 deg	19 deg	50/163	16640
FW351KS5	305 mm	20 mm	423 kg	19 deg	19 deg	50/163	16640

pro-hitch 351 Cast Fifth Wheels On A Double Row Ballrace/Kompensator

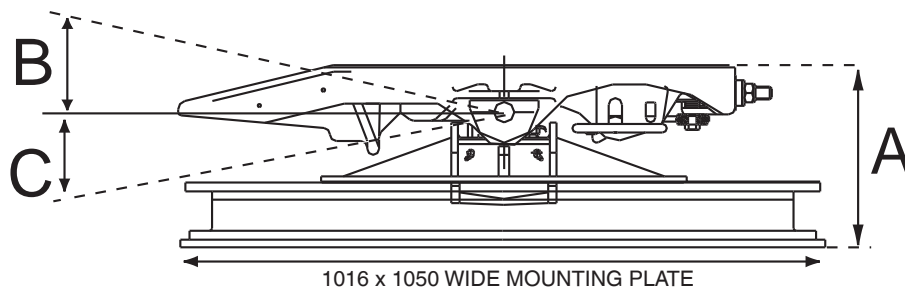

Part Number	Height (A)	Base Plate Thickness	Assembly Weight	Oscillation		D-Rating kN	CRN Number
				B	C		
FW351KD4	331 mm	16 mm	418 kg	19 deg	19 deg	50/163	16636
FW351KD5	335 mm	20 mm	443 kg	19 deg	19 deg	50/163	16636

Note: Kompensator Allows 5 degree of oscillation either side of Vertical centre line. Centre of gravity not to exceed 1120mm above Fifth Wheel Top Plate Surface

Specifications regarding heights and weights are nominal only. We reserve the right to make changes as necessary.

Not suitable for livestock



GO THE DISTANCE.

FIFTH WHEELS

pro-hitch 351 Cast Fifth Wheel Options

CAST STEEL Construction to suit 50mm Kingpin.

All Fifth Wheel packages: Tested to AS4968 series under requirements of ADR 62/01

pro-hitch351 D rating: 50/165

As configurations can change, please refer to the respective assembly or part no. for the correct & applicable D rating.

pro-hitch 351 Cast Fifth Wheels On A Slider



Base width 1003mm. Travel in 50.8 mm increments.

Part Number	Height (A)	Assembly Weight	Oscillation Fore	Oscillation AFT	Travel Length	Base Length	D-Rating kN	CRN Number
FW35112	173mm	219.4 kg	8 deg	8 deg	610mm	1135mm	TBA	TBA
FW35122	198mm	220.4 kg	10 deg	12 deg	610mm	1135mm	TBA	TBA
FW35132	223mm	222.2 kg	15 deg	15 deg	610mm	1135mm	TBA	TBA

Part Number	Height (A)	Assembly Weight	Oscillation Fore	Oscillation AFT	Travel Length	Base Length	D-Rating kN	CRN Number
FW35113	173mm	236.5 kg	8 deg	8 deg	915mm	1440mm	TBA	TBA
FW35123	198mm	238.1 kg	10 deg	12 deg	915mm	1440mm	TBA	TBA
FW35133	223mm	239.9 kg	15 deg	15 deg	915mm	1440mm	TBA	TBA

Note: All weights are nominal and subject to variation.

pro-hitch 351 Handle Option

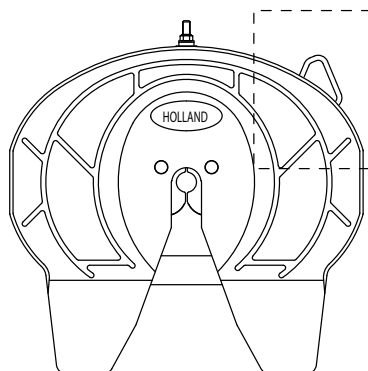

B-Double

When ordering "B" Double configuration add 'B' to 351 part no. eg FW351AB. Will attract same CRN and Assembly numbers as standard models.

Note: Ears removed from top plate to minimum width 915mm. All weights, oscillation, Ratings as per standard 351 assembly specs. When uncoupled release handle does not protrude past the casting width.

Note: Specifications regarding heights and weights are nominal only. We reserve the right to make changes as necessary.

Not suitable for livestock



GO THE DISTANCE.

FW342

FW342 Lo-Lube
Cast Fifth Wheel Assemblies

D Rating: 50/165 kN

A variation of the pro-hitch 351,
the Lo-Lube is best suited for
dedicated vehicle combinations up to 165 kN.

*Note: Not suitable for livestock.



GO THE DISTANCE.

FIFTH WHEELS

FW342 Low-Lube Cast Fifth Wheels

Section: 1 - 2a

CAST STEEL Construction to suit 50mm Kingpin to AS4968 series.

All Fifth Wheel packages: Tested to AS4968 series under requirements of ADR 62/01

342 D rating: 50/165

As configurations can change, please refer to the respective assembly or part no. for the correct & applicable D rating.

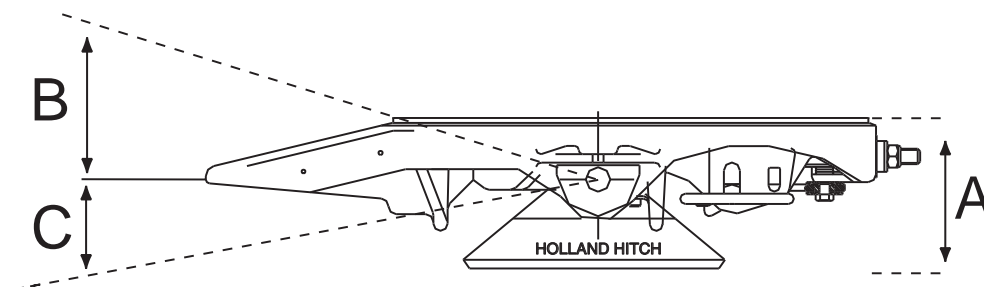

Part Number	Height (A)	Assembly Weight	Oscillation		D-Rating kN	CRN Number
			B	C		
*XA342A	-	110 kg	Top Only		50/165	N/A
**FW342L	153 mm	123 kg	10 deg	8 deg	50/165	16753
**FW342T	175 mm	128 kg	15 deg	12 deg	50/165	16753
FW342F	198 mm	130 kg	18 deg	16 deg	50/165	16753
FW342A	208 mm	131 kg	21 deg	18 deg	50/165	16753
FW342X	243 mm	136 kg	29 deg	23 deg	50/165	16753

* Top plate only -c/w foot pins & fixings.

** Restricted Angle of Pitch - Base plate must have cut outs to allow for the minimum 8 degrees fore & aft oscillation.

Note: - All FW342 cast fifth wheels complete with feet are now using a cast steel weld on type foot.

- Not suitable for livestock



GO THE DISTANCE.

FIFTH WHEELS

FW342 Low-Lube Cast Fifth Wheels On A Base Plate

Section: 1 - 2b

CAST STEEL Construction to suit 50mm Kingpin.

All Fifth Wheel packages: Tested to AS4968 series under requirements of ADR 62/01

342 D rating: 50/165

As configurations can change, please refer to the respective assembly or part no. for the correct & applicable D rating.

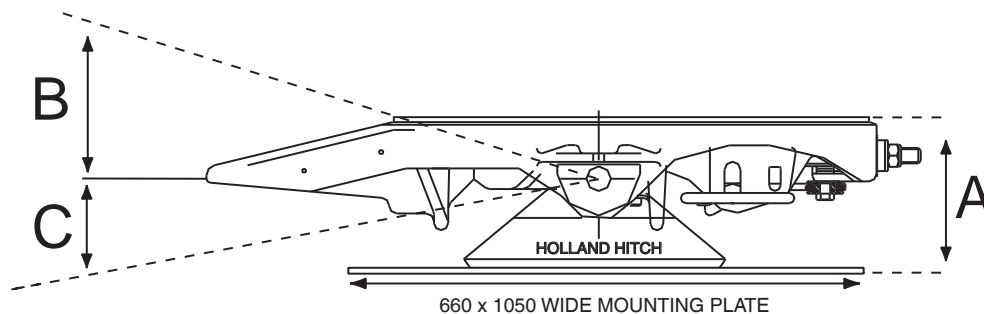

Part Number	Height (A)	Base Plate Thickness	Assembly Weight	Oscillation		D-Rating kN	CRN Number
				B	C		
*FW342L2	169 mm	16 mm	214 kg	10 deg	8 deg	50/165	16625
*FW342L3	173 mm	20 mm	241 kg	10 deg	8 deg	50/165	16625
*FW342T2	191 mm	16 mm	220 kg	15 deg	12 deg	50/165	16625
*FW342T3	195 mm	20 mm	246 kg	15 deg	12 deg	50/165	16625
FW342F2	214 mm	16 mm	222 kg	18 deg	16 deg	50/165	16625
FW342F3	218 mm	20 mm	248 kg	18 deg	16 deg	50/165	16625
FW342A2	224 mm	16 mm	223 kg	21 deg	18 deg	50/165	16625
FW342A3	228 mm	20 mm	249 kg	21 deg	18 deg	50/165	16625
FW342X2	259 mm	16 mm	227 kg	29 deg	23 deg	50/165	16625
FW342X3	263 mm	20 mm	254 kg	29 deg	23 deg	50/165	16625

* Restricted Angle of Pitch - Base plate must have cut outs to allow for the minimum 8 degrees fore & aft oscillation.

Note: Specifications regarding heights and weights are nominal only. We reserve the right to make changes as necessary.

Not suitable for livestock



FIFTH WHEELS

FW342 Low-Lube Cast Fifth Wheels On A Single Row Ballrace Assembly

CAST STEEL Construction to suit 50mm Kingpin.

All Fifth Wheel packages: Tested to AS4968 series under requirements of ADR 62/01

342 D rating: 50/165

As configurations can change, please refer to the respective assembly or part no. for the correct & applicable D rating.

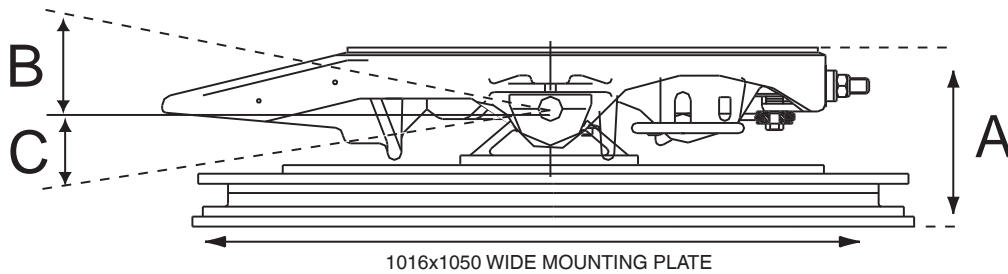

Part Number	Height (A)	Base Plate Thickness	Assembly Weight	Oscillation		D-Rating kN	CRN Number
				B	C		
FW342LS4	241 mm	16 mm	319 kg	13 deg	9 deg	50/165	16641
FW342TS4	263 mm	16 mm	320 kg	13 deg	12 deg	50/165	16641
FW342AS4	296 mm	16 mm	323 kg	17 deg	12 deg	50/165	16641

FW342 Lo-Lube Cast Fifth Wheels On A Double Row Ballrace Assembly

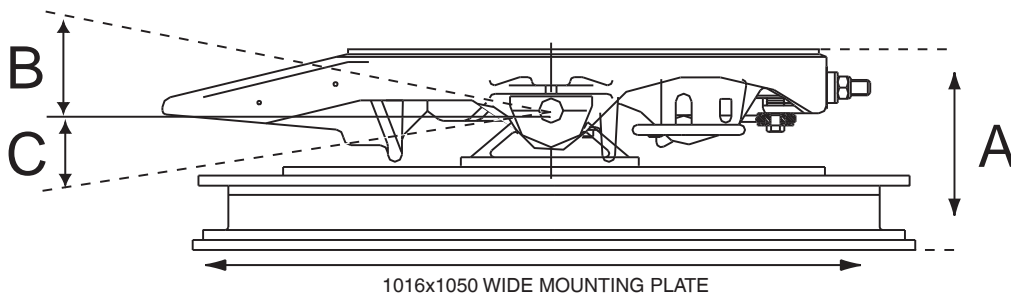

Part Number	Height (A)	Base Plate Thickness	Assembly Weight	Oscillation		D-Rating kN	CRN Number
				B	C		
FW342LD4	271 mm	16 mm	340 kg	13 deg	9 deg	50/165	16627
FW342TD4	293 mm	16 mm	341 kg	17 deg	12 deg	50/165	16627
FW342AD4	326 mm	16 mm	344 kg	17 deg	12 deg	50/165	16627

Note: 'S' Suffix in part number = Single row ball race.

'D' Suffix in part number = Double row ball race.

Specifications regarding heights and weights are nominal only. We reserve the right to make changes as necessary.

Not suitable for livestock



GO THE DISTANCE.

FIFTH WHEELS

FW342 Low-Lube Cast Fifth Wheels On A Kompensator

CAST STEEL Construction to suit 50mm Kingpin.

All Fifth Wheel packages: Tested to AS4968 series under requirements of ADR 62/01

342 D rating: 50/165

As configurations can change, please refer to the respective assembly or part no. for the correct & applicable D rating.

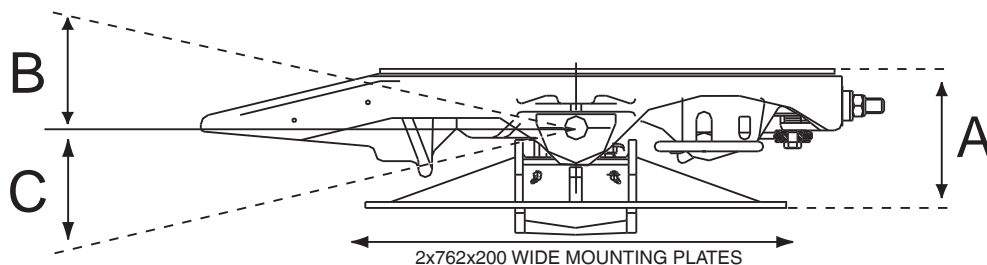

Part Number	Height (A)	Base Plate Thickness	Assembly Weight	Oscillation B	Oscillation C	D-Rating kN	CRN Number
FW342K	250 mm	12 mm	241 kg	23 deg	23 deg	50/163	16629

FW342 Lo-Lube Cast Fifth Wheels On A Kompensator Full Plate

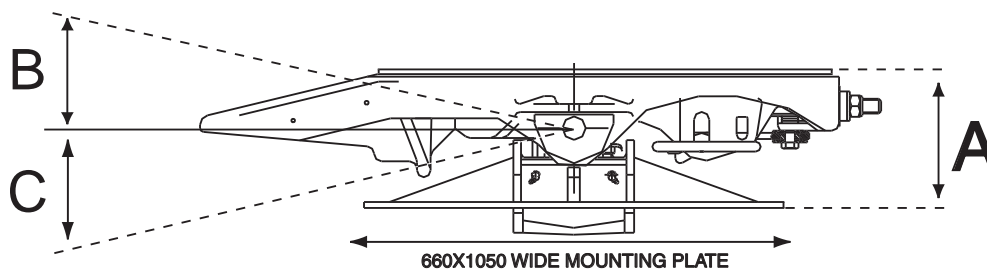

Part Number	Height (A)	Base Plate Thickness	Assembly Weight	Oscillation B	Oscillation C	D-Rating kN	CRN Number
FW342KP	250 mm	12 mm	265 kg	23 deg	23 deg	50/163	16628
FW342KP6	254 mm	16 mm	282 kg	23 deg	23 deg	50/163	16628
FW342KP7	258 mm	20 mm	299 kg	23 deg	23 deg	50/163	16628

Note: Kompensator Allows 5 degree of oscillation either side of vertical centre line. Centre of gravity not to exceed 1120mm above Fifth Wheel Top Plate Surface.

Specifications regarding heights and weights are nominal only. We reserve the right to make changes as necessary.

Not suitable for livestock



GO THE DISTANCE.

FIFTH WHEELS

FW342 Low-Lube Cast Fifth Wheels On A Single Row Ballrace/ Kompensator

Section: 1 - 2e

CAST STEEL Construction to suit 50mm Kingpin.

All Fifth Wheel packages: Tested to AS4968 series under requirements of ADR 62/01

342 D rating: 50/165

As configurations can change, please refer to the respective assembly or part no. for the correct & applicable D rating.

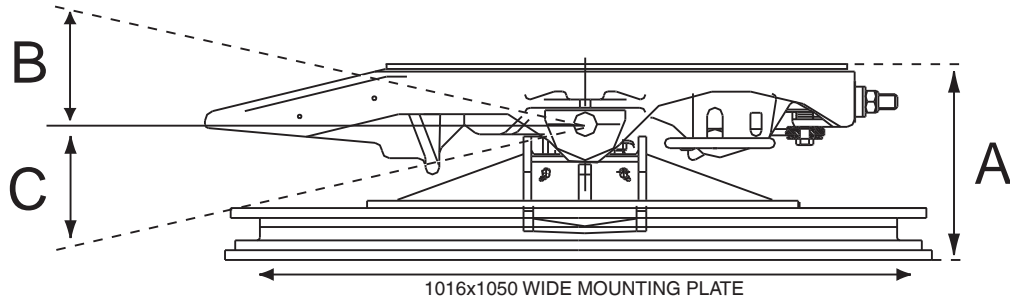

Part Number	Height (A)	Base Plate Thickness	Assembly Weight	Oscillation		D-Rating kN	CRN Number
				B	C		
FW342KS4	311 mm	16 mm	397 kg	19 deg	19 deg	50/163	16640
FW342KS5	315 mm	20 mm	423 kg	19 deg	19 deg	50/163	16640

FW342 Lo-Lube Cast Fifth Wheels On A Double Row Ballrace/Kompensator

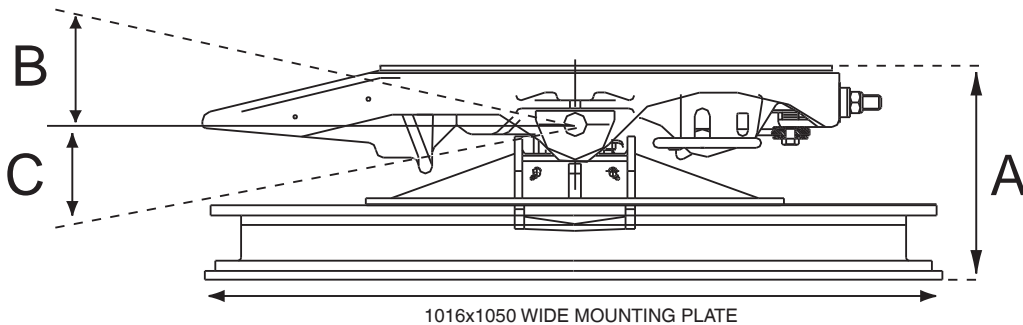

Part Number	Height (A)	Base Plate Thickness	Assembly Weight	Oscillation		D-Rating kN	CRN Number
				B	C		
FW342KD4	341 mm	16 mm	418 kg	19 deg	19 deg	50/163	16636
FW342KD5	345 mm	20 mm	443 kg	19 deg	19 deg	50/163	16636

Note: Kompensator Allows 5 degree of oscillation either side of Vertical centre line. Centre of gravity not to exceed 1120mm above Fifth Wheel Top Plate Surface.

Specifications regarding heights and weights are nominal only. We reserve the right to make changes as necessary.

Not suitable for livestock



GO THE DISTANCE.

FIFTH WHEELS

FW342 Low-Lube Cast Fifth Wheel Options

Section: 1 - 2f

CAST STEEL Construction to suit 50mm Kingpin.

All Fifth Wheel packages: Tested to AS4968 series under requirements of ADR 62/01

342 D rating: 50/165

As configurations can change, please refer to the respective assembly or part no. for the correct & applicable D rating.

FW342 Lo-Lube Cast Fifth Wheel On A Slider



Base width 1003mm. Travel in 50.8 mm increments.

Part Number	Height (A)	Assembly Weight	Oscillation		Travel Length	Base Length	D-Rating kN	CRN Number
			Fore	AFT				
FW34212	182mm	219.4 kg	8 deg	8 deg	610mm	1135mm	TBA	TBA
FW34222	207mm	220.4 kg	10 deg	12 deg	610mm	1135mm	TBA	TBA
FW34232	233mm	222.2 kg	15 deg	15 deg	610mm	1135mm	TBA	TBA

Part Number	Height (A)	Assembly Weight	Oscillation		Travel Length	Base Length	D-Rating kN	CRN Number
			Fore	AFT				
FW34213	182mm	236.5 kg	8 deg	8 deg	915mm	1440mm	TBA	TBA
FW34223	207mm	238.1 kg	10 deg	12 deg	915mm	1440mm	TBA	TBA
FW34233	233mm	239.9 kg	15 deg	15 deg	915mm	1440mm	TBA	TBA

Note: All weights are nominal and subject to variation.

FW342 Lo-Lube Handle Option

B-Double

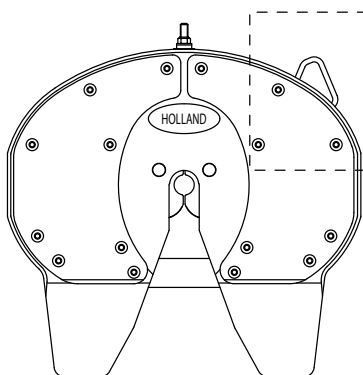

When ordering "B" Double configuration add 'B' to 342 part no. eg FW342AB. Will attract same CRN and Assembly numbers as standard models.

Note: Ears removed from top plate to minimum width 915mm. All weights, oscillation, Ratings as per standard 342 assembly specs. When uncoupled release handle does not protrude past the casting width.

Note: Specifications regarding heights and weights are nominal only. We reserve the right to make changes as necessary.

Not suitable for livestock



GO THE DISTANCE.

FW70

FW70
Cast Fifth Wheel Assemblies

D Rating: 50/240 kN
90/270 kN

Holland's standard heavy duty fifth wheel,
suited for heavy haulage, off road,
low loaders, floats.
drop deck and livestock applications.



FIFTH WHEELS

FW70 Cast Fifth Wheels

GO THE DISTANCE.

CAST STEEL Construction to suit 50 & 90mm Kingpin.

All Fifth Wheel package: Tested to AS4968 series under requirements of ADR 62/D1

FW70 D rating: 50/D 240 (50mm) & 90/D 270 (90 mm).

As configurations can change, please refer to the respective assembly or part no. for the correct & applicable D rating.

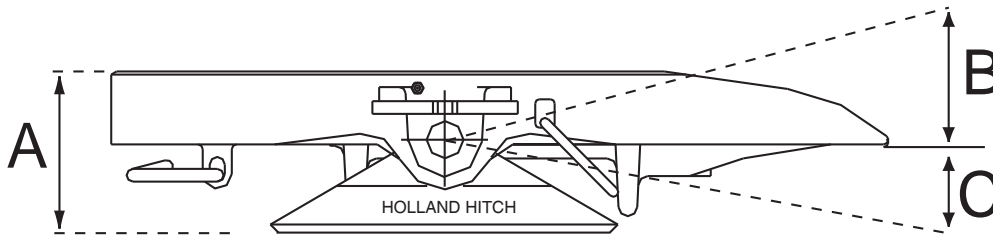

FW70 50mm Top Plate

Part Number	Height (A)	Assembly Weight	Oscillation		D-Rating kN	CRN Number
			B	C		
*FW70D	N/A	153 kg	Top Only		N/A	N/A
FW70DT	165 mm	172 kg	10 deg	11 deg	50/240	16755
FW70DF	188 mm	174 kg	18 deg	16 deg	50/240	16755
FW70DA	198 mm	175 kg	20 deg	18 deg	50/240	16755
FW70DX	232 mm	179 kg	26 deg	24 deg	50/240	16755

FW70 90mm Top Plate

Part Number	Height (A)	Assembly Weight	Oscillation		D-Rating kN	CRN Number
			B	C		
*FW70O	N/A	154 kg	Top Only		N/A	N/A
FW70OT	165 mm	173 kg	10 deg	11 deg	90/240	16756
FW70OF	188 mm	175 kg	18 deg	16 deg	90/240	16756
FW70OA	198 mm	176 kg	20 deg	18 deg	90/240	16756
FW70OX	232 mm	180 kg	26 deg	24 deg	90/240	16756

* Top plate only - c/w foot pins and fixings

Note: All FW70 Fifth Wheel assemblies are supplied in LH Release as standard.

RH Release is available, use the suffix "R" when ordering this option. ie: FW70DT2 becomes FW70DT2R.

Specifications regarding heights and weights are nominal only. We reserve the right to make changes a necessary.



FIFTH WHEELS

FW70 Cast Fifth Wheels On A Base Plate

GO THE DISTANCE.

CAST STEEL Construction to suit 50 & 90mm Kingpin.

All Fifth Wheel package: Tested to AS4968 series under requirements of ADR 62/D1

FW70 D rating: 50/D 240 (50mm) & 90/D 270 (90 mm).

As configurations can change, please refer to the respective assembly or part no. for the correct & applicable D rating.

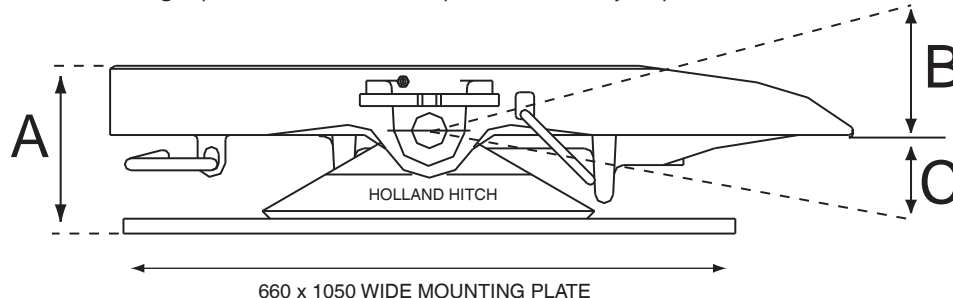

FW70 50mm Top Plate

Part Number	Height (A)	Base Plate Thickness	Assembly Weight	Oscillation		D-Rating kN	CRN Number
				B	C		
FW70DL2	159 mm	16 mm	258 kg	8 deg	8 deg	50/240	16642
FW70DL3	163 mm	20 mm	284 kg	8 deg	8 deg	50/240	16647
FW70DT2	181 mm	16 mm	263 kg	10 deg	11 deg	50/240	16642
FW70DT3	185 mm	20 mm	290 kg	10 deg	11 deg	50/240	16647
FW70DF2	204 mm	16 mm	265 kg	16 deg	18 deg	50/240	16642
FW70DF3	208 mm	20 mm	292 kg	16 deg	18 deg	50/240	16647
FW70DA2	214 mm	16 mm	266 kg	20 deg	19 deg	50/240	16642
FW70DA3	218 mm	20 mm	293 kg	20 deg	19 deg	50/240	16647
FW70DX2	249 mm	16 mm	271 kg	26 deg	23 deg	50/240	16642
FW70DX3	253 mm	20 mm	298 kg	26 deg	23 deg	50/240	16647

FW70 90mm Top Plate

Part Number	Height (A)	Base Plate Thickness	Assembly Weight	Oscillation		D-Rating kN	CRN Number
				B	C		
FW70OL2	159 mm	16 mm	259 kg	8 deg	8 deg	90/270	36513
FW70OL3	163 mm	20 mm	285 kg	8 deg	8 deg	90/240	16660
FW70OT2	181 mm	16 mm	264 kg	10 deg	11 deg	90/270	36513
FW70OT3	185 mm	20 mm	291 kg	10 deg	11 deg	90/240	16660
FW70OF2	204 mm	16 mm	266 kg	16 deg	18 deg	90/270	36513
FW70OF3	208 mm	20 mm	293 kg	16 deg	18 deg	90/240	16660
FW70OA2	214 mm	16 mm	267 kg	20 deg	19 deg	90/270	36513
FW70OA3	218 mm	20 mm	294 kg	20 deg	19 deg	90/240	16660
FW70OX2	249 mm	16 mm	272 kg	26 deg	23 deg	90/270	36513
FW70OX3	253 mm	20 mm	299 kg	26 deg	23 deg	90/240	16660

Note: All FW70 Fifth Wheel assemblies are supplied in LH Release as standard.

RH Release is available, use the suffix "R" when ordering this option. ie: FW70DT2 becomes FW70DT2R.

Specifications regarding heights and weights are nominal only. We reserve the right to make changes a necessary.



GO THE DISTANCE.

FIFTH WHEELS

FW70 Cast Fifth Wheels On A Single Row Ballrace Assembly

CAST STEEL Construction to suit 50 & 90mm Kingpin.

All Fifth Wheel package: Tested to AS4968 series under requirements of ADR 62/D1

FW70 D rating: 50/D 240 (50mm) & 90/D 270 (90 mm).

As configurations can change, please refer to the respective assembly or part no. for the correct & applicable D rating.

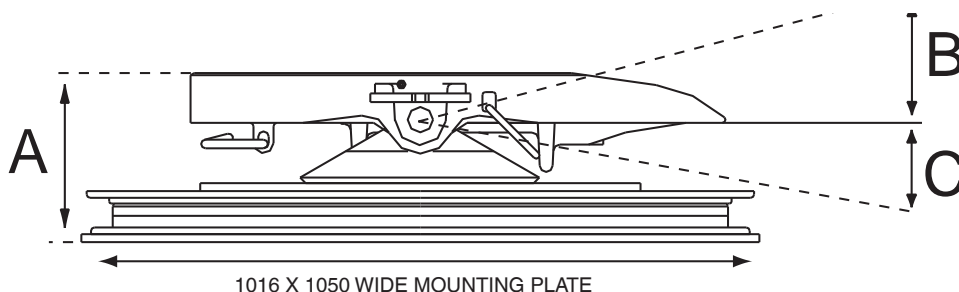

FW70 50mm Top Plate

Part Number	Height (A)	Base Plate Thickness	Assembly Weight	Oscillation		D-Rating kN	CRN Number
				B	C		
FW70DLS4	231 mm	16 mm	362 kg	15 deg	12 deg	50/190	16645
FW70DLS5	235 mm	20 mm	388 kg	15 deg	12 deg	50/190	16645
FW70DTS4	253 mm	16 mm	363 kg	16 deg	13 deg	50/190	16645
FW70DTS5	257 mm	20 mm	389 kg	16 deg	13 deg	50/190	16645
FW70DAS4	286 mm	16 mm	366 kg	21 deg	16 deg	50/190	16645
FW70DAS5	290 mm	20 mm	392 kg	21 deg	16 deg	50/190	16645

FW70 90mm Top Plate

Part Number	Height (A)	Base Plate Thickness	Assembly Weight	Oscillation		D-Rating kN	CRN Number
				B	C		
FW70OLS4	231 mm	16 mm	363 kg	15 deg	12 deg	90/190	16664
FW70OLS5	235 mm	20 mm	389 kg	15 deg	12 deg	90/190	16664
FW70OTS4	253 mm	16 mm	364 kg	16 deg	13 deg	90/190	16664
FW70OTS5	257 mm	20 mm	390 kg	16 deg	13 deg	90/190	16664
FW70OAS4	286 mm	16 mm	367 kg	21 deg	16 deg	90/190	16664
FW70OAS5	290 mm	20 mm	393 kg	21 deg	16 deg	90/190	16664

Note: All FW70 Fifth Wheel assemblies are supplied in LH Release as standard.

RH Release is available, use the suffix "R" when ordering this option. ie: FW70DT2 becomes FW70DT2R.

Specifications regarding heights and weights are nominal only. We reserve the right to make changes a necessary.



FIFTH WHEELS

FW70 Cast Fifth Wheels On A Double Row Ballrace Assembly

CAST STEEL Construction to suit 50 & 90mm Kingpin.

All Fifth Wheel package: Tested to AS4968 series under requirements of ADR 62/D1

FW70 D rating: 50/D 240 (50mm) & 90/D 270 (90 mm).

As configurations can change, please refer to the respective assembly or part no. for the correct & applicable D rating.

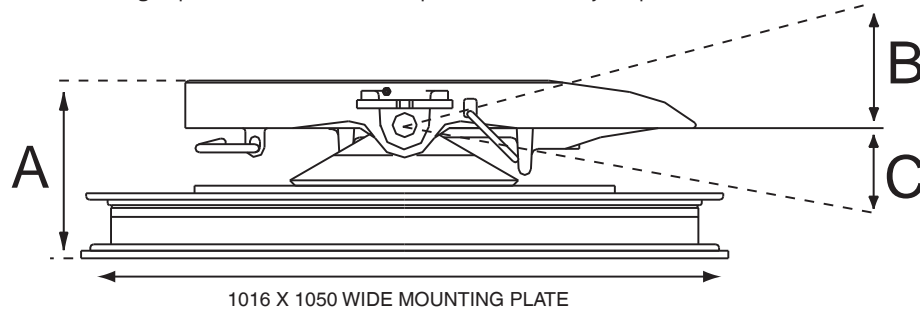

FW70 50mm Top Plate

Part Number	Height (A)	Base Plate Thickness	Assembly Weight	Oscillation		D-Rating kN	CRN Number
				B	C		
FW70DLD4	261 mm	16 mm	383 kg	15 deg	12 deg	50/240	16644
FW70DLD5	265 mm	20 mm	409 kg	15 deg	12 deg	50/240	16644
FW70DTD4	283 mm	16 mm	384 kg	16 deg	13 deg	50/240	16644
FW70DTD5	287 mm	20 mm	410 kg	16 deg	13 deg	50/240	16644
FW70DAD4	316 mm	16 mm	387 kg	21 deg	16 deg	50/240	16644
FW70DAD5	320 mm	20 mm	413 kg	21 deg	16 deg	50/240	16644

FW70 90mm Top Plate

Part Number	Height (A)	Base Plate Thickness	Assembly Weight	Oscillation		D-Rating kN	CRN Number
				B	C		
FW70OLD4	261 mm	16 mm	384 kg	15 deg	12 deg	90/270	16661
FW70OLD5	265 mm	20 mm	410 kg	15 deg	12 deg	90/270	16661
FW70OTD4	283 mm	16 mm	385 kg	16 deg	13 deg	90/270	16661
FW70OTD5	287 mm	20 mm	411 kg	16 deg	13 deg	90/270	16661
FW70OAD4	316 mm	16 mm	388 kg	21 deg	16 deg	90/270	16661
FW70OAD5	320 mm	20 mm	412 kg	21 deg	16 deg	90/270	16661

Note: All FW70 Fifth Wheel assemblies are supplied in LH Release as standard.

RH Release is available, use the suffix "R" when ordering this option. ie: FW70DT2 becomes FW70DT2R.

Specifications regarding heights and weights are nominal only. We reserve the right to make changes a necessary.



GO THE DISTANCE.

FIFTH WHEELS

FW70 Cast Fifth Wheels On A Kompensator

Section 1 - 3e

CAST STEEL Construction to suit 50 & 90mm Kingpin.

All Fifth Wheel package: Tested to AS4968 series under requirements of ADR 62/D1

FW70 D rating: 50/D 240 (50mm) & 90/D 270 (90 mm).

As configurations can change, please refer to the respective assembly or part no. for the correct & applicable D rating.

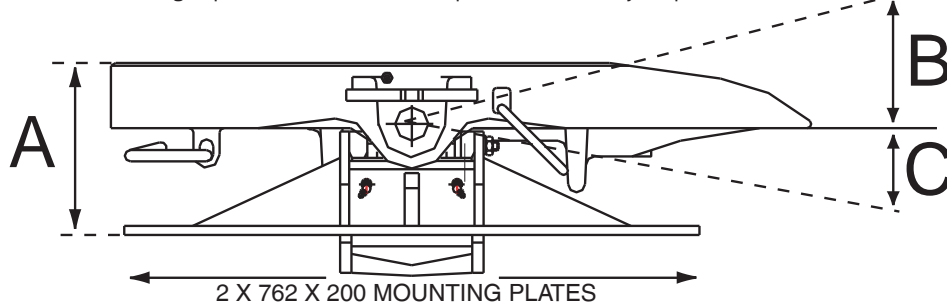

Part Number	Height (A)	Base Plate Thickness	Assembly Weight	Oscillation		D-Rating kN	CRN Number
				B	C		
FW70DK	240 mm	12 mm	284 kg	19 deg	16 deg	50/163	16648
FW70OK	240 mm	12 mm	285 kg	19 deg	16 deg	90/163	16667

FW70 Cast Fifth Wheels On A Kompensator Full Plate

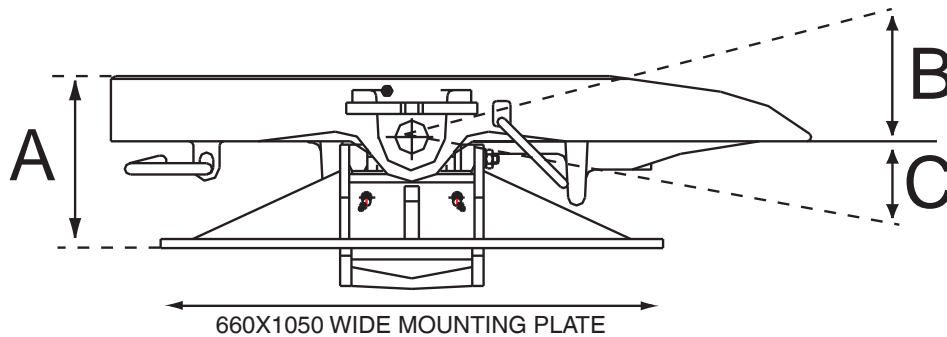

Part Number	Height (A)	Base Plate Thickness	Assembly Weight	Oscillation		D-Rating kN	CRN Number
				B	C		
FW70DKP	240 mm	12 mm	305 kg	19 deg	16 deg	50/163	16795
FW70DKP6	244 mm	16 mm	325 kg	19 deg	16 deg	50/163	16795
FW70DKP7	248 mm	20 mm	342 kg	19 deg	16 deg	50/163	16795
FW70OKP	240 mm	12 mm	306 kg	19 deg	16 deg	90/163	16796
FW70OKP6	244 mm	16 mm	326 kg	19 deg	16 deg	90/163	16796
FW70OKP7	248 mm	20 mm	343 kg	19 deg	16 deg	90/163	16796

Note: Kompensator Allows 5 degree of oscillation either side of vertical centre line. Centre of gravity not to exceed 1120mm above Fifth Wheel Top Plate Surface.

All FW70 Fifth Wheel assemblies are supplied in LH Release as standard.

RH Release is available, use the suffix "R" when ordering this option. ie: FW70DT2 becomes FW70DT2R.

Specifications regarding heights and weights are nominal only. We reserve the right to make changes as necessary.



FIFTH WHEELS

FW70 Cast Fifth Wheels On A Single Row Ballrace/ Kompensator

CAST STEEL Construction to suit 50 & 90mm Kingpin.

All Fifth Wheel package: Tested to AS4968 series under requirements of ADR 62/D1

FW70 D rating: 50/D 240 (50mm) & 90/D 270 (90 mm).

As configurations can change, please refer to the respective assembly or part no. for the correct & applicable D rating.

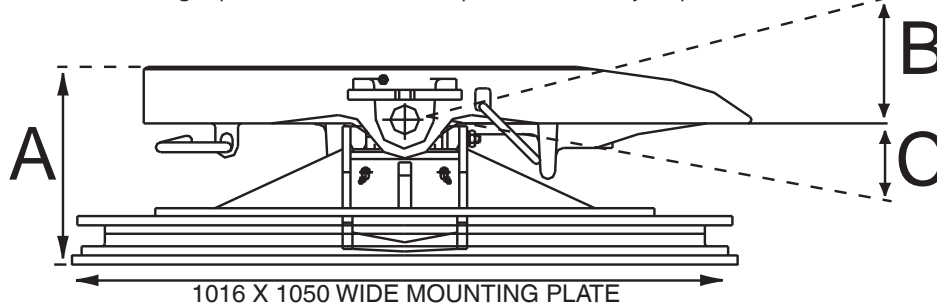

Part Number	Height (A)	Base Plate Thickness	Assembly Weight	Oscillation		D-Rating kN	CRN Number
				B	C		
FW70DKS4	291 mm	16 mm	441 kg	19 deg	16 deg	50/163	16649
FW70DKS5	295 mm	20 mm	467 kg	19 deg	16 deg	50/163	16649
FW70OKS4	291 mm	16 mm	442 kg	19 deg	16 deg	90/163	16663
FW70OKS5	295 mm	20 mm	468 kg	19 deg	16 deg	90/163	16663

FW70 Cast Fifth Wheels On A Double Row Ballrace/Kompensator

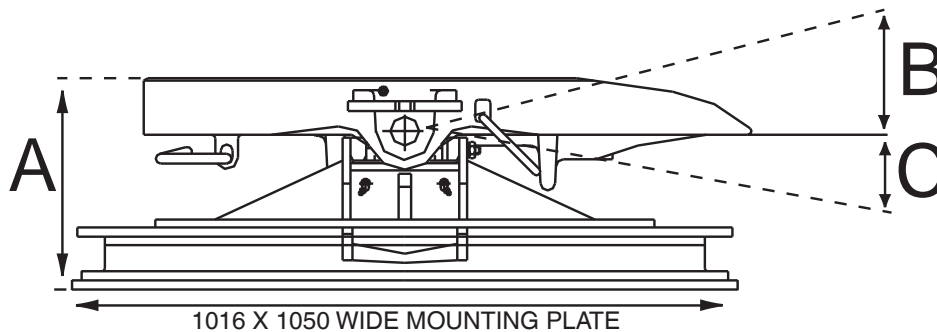

Part Number	Height (A)	Base Plate Thickness	Assembly Weight	Oscillation		D-Rating kN	CRN Number
				B	C		
FW70DKD4	321 mm	16 mm	461 kg	19 deg	16 deg	50/163	16646
FW70DKD5	325 mm	20 mm	486 kg	19 deg	16 deg	50/163	16646
FW70OKD4	321 mm	16 mm	462 kg	19 deg	16 deg	90/163	16662
FW70OKD5	325 mm	20 mm	487 kg	19 deg	16 deg	90/163	16662

Note: Kompensator Allows 5 degree of oscillation either side of vertical centre line. Centre of gravity not to exceed 1120mm above Fifth Wheel Top Plate Surface.

All FW70 Fifth Wheel assemblies are supplied in LH Release as standard.

RH Release is available, use the suffix "R" when ordering this option. ie: FW70DT2 becomes FW70DT2R.

Specifications regarding heights and weights are nominal only. We reserve the right to make changes as necessary.



GO THE DISTANCE.

FIFTH WHEELS

FW70 Cast Fifth Wheel Slider Options

Section 1 - 3g

CAST STEEL Construction to suit 50 & 90mm Kingpin.

All Fifth Wheel package: Tested to AS4968 series under requirements of ADR 62/D1

FW70 D rating: 50/D 240 (50mm) & 90/D 270 (90 mm).

As configurations can change, please refer to the respective assembly or part no. for the correct & applicable D rating.

Heavy Duty Air Slider Fixed

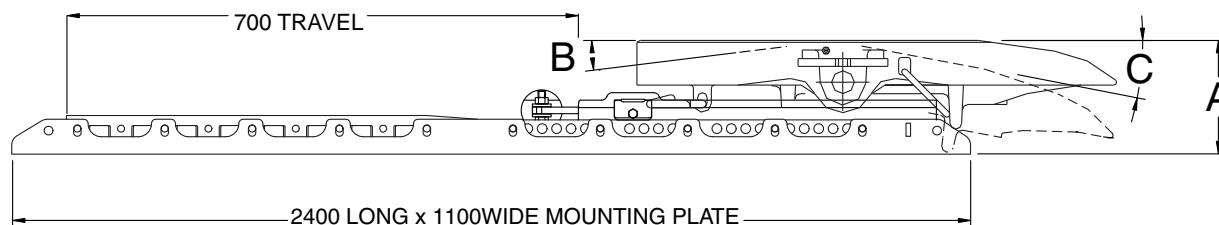

FW70 50mm Top Plate

Part Number	Height (A)	Assembly Weight	Oscillation B	Oscillation C	Travel Length	D-Rating kN	CRN Number
FWS70DL	183 mm	442 kg	8 deg	8 deg	700 mm	50/240	TBA
FWS70DT	205 mm	447 kg	10 deg	11 deg	700 mm	50/240	TBA
FWS70DF	228 mm	449 kg	18 deg	16 deg	700 mm	50/240	TBA
FWS70DA	238 mm	450 kg	20 deg	18 deg	700 mm	50/240	TBA
FWS70DX	272 mm	455 kg	26 deg	24 deg	700 mm	50/240	TBA

FW70 90mm Top Plate

Part Number	Height (A)	Assembly Weight	Oscillation B	Oscillation C	Travel Length	D-Rating kN	CRN Number
FWS70OL	183 mm	443 kg	8 deg	8 deg	700 mm	90/270	TBA
FWS70OT	205 mm	448 kg	10 deg	11 deg	700 mm	90/270	TBA
FWS70OF	228 mm	450 kg	18 deg	16 deg	700 mm	90/270	TBA
FWS70OA	238 mm	451 kg	20 deg	18 deg	700 mm	90/270	TBA
FWS70OX	272 mm	456 kg	26 deg	24 deg	700 mm	90/270	TBA

Note: All FW70 Fifth Wheel assemblies are supplied in LH Release as standard.

RH Release is available, use the suffix "R" when ordering this option. ie: FW70DT2 becomes FW70DT2R.

Specifications regarding heights and weights are nominal only. We reserve the right to make changes a necessary.



GO THE DISTANCE.

FIFTH WHEELS

FW70 Cast Fifth Wheel Slider Options cont...

CAST STEEL Construction to suit 50 & 90mm Kingpin.

All Fifth Wheel package: Tested to AS4968 series under requirements of ADR 62/D1

FW70 D rating: 50/D 240 (50mm) & 90/D 270 (90 mm).

SR 60/1000 Rating D/190

DR 90/1000 Rating D/270

As configurations can change, please refer to the respective assembly or part no. for the correct & applicable D rating.

Heavy Duty Air Slider Ballrace

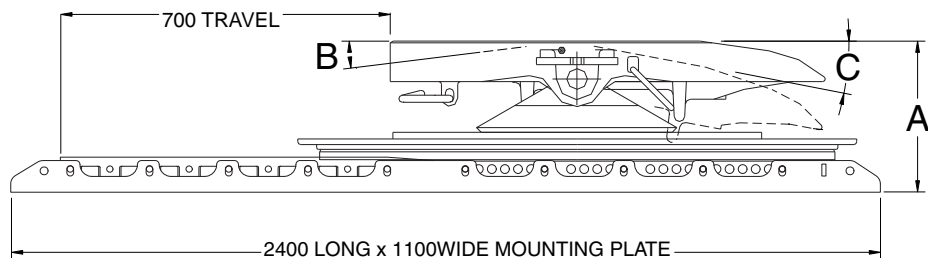

FW70 50mm Top Plate

Part Number	Height (A)	Assembly Weight	Oscillation B	Oscillation C	Travel Length	D-Rating kN	CRN Number
FWS70DLS	255 mm	608 kg	15 deg	12 deg	700 mm	50/190	TBA
FWS70DTS	277 mm	609 kg	16 deg	13 deg	700 mm	50/190	TBA
FWS70DLD	285 mm	629 kg	15 deg	12 deg	700 mm	50/240	TBA
FWS70DTD	307 mm	630 kg	16 deg	13 deg	700 mm	50/240	TBA

FW70 90mm Top Plate

Part Number	Height (A)	Assembly Weight	Oscillation B	Oscillation C	Travel Length	D-Rating kN	CRN Number
FWS70OLS	255 mm	609 kg	15 deg	12 deg	700 mm	90/190	TBA
FWS70OTS	277 mm	610 kg	16 deg	13 deg	700 mm	90/190	TBA
FWS70OLD	285 mm	630 kg	15 deg	12 deg	700 mm	90/270	TBA
FWS70OTD	307 mm	631 kg	16 deg	13 deg	700 mm	90/270	TBA

Note: All FW70 Fifth Wheel assemblies are supplied in LH Release as standard.

RH Release is available, use the suffix "R" when ordering this option. ie: FW70DT2 becomes FW70DT2R.

Specifications regarding heights and weights are nominal only. We reserve the right to make changes a necessary.



GO THE DISTANCE.

FIFTH WHEELS

FW70 Handle Option

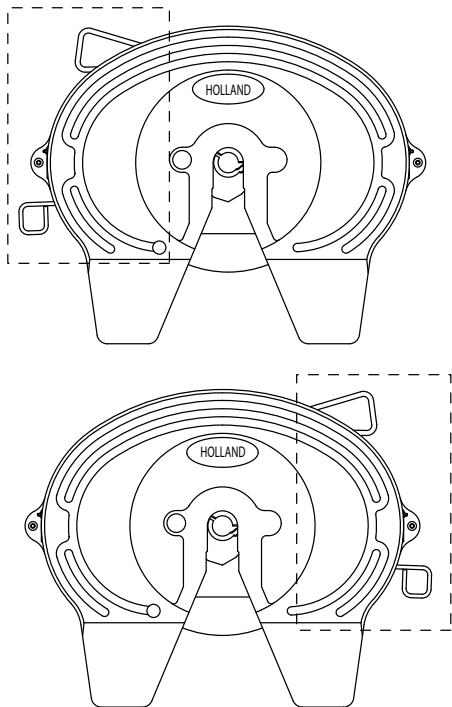

RH Release Handle

When ordering a "RH Release handle option, add suffix "R" to the fifth wheel part number. eg: FW70DTR.

This attracts the same CRN and number as the standard LH Release models.

Note: All FW70 Fifth Wheel assemblies are supplied in LH Release as standard. RH Release is available, use the suffix "R" when ordering this option. ie: FW70DT2 becomes FW70DT2R. Specifications regarding heights and weights are nominal only. We reserve the right to make changes a necessary.



GO THE DISTANCE.

FW72

FW72 Lo-Lube
Cast Fifth Wheel Assemblies

D Rating: 50/240 kN
90/270 kN

Holland's Lo-Lube heavy duty fifth wheel,
suited for heavy haulage, off road,
low loaders, floats.
drop deck and livestock applications.



GO THE DISTANCE.

FIFTH WHEELS

FW72 Lo-Lube Cast Fifth Wheels

Section 1 - 4a

CAST STEEL Construction to suit 50 & 90mm Kingpin.

All Fifth Wheel package: Tested to AS4968 series under requirements of ADR 62/O1

FW72 Lo-Lube D rating: 50/D 240 (50mm) & 90/D 270 (90 mm).

As configurations can change, please refer to the respective assembly or part no. for the correct & applicable D rating.

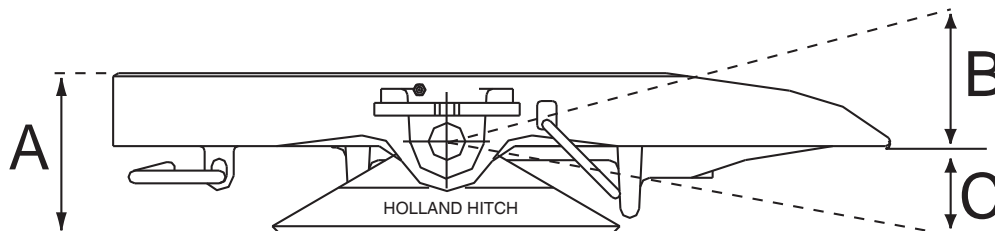

FW72 Lo-Lube 50mm Top Plate

Part Number	Height (A)	Assembly Weight	Oscillation		D-Rating kN	CRN Number
			B	C		
*FW72D	N/A	145 kg	Top Only		N/A	N/A
FW72DT	168 mm	164 kg	10 deg	N/A	50/240	16755
FW72DF	191 mm	166 kg	18 deg	16 deg	50/240	16755
FW72DA	201 mm	167 kg	20 deg	18 deg	50/240	16755
FW72DX	235 mm	171 kg	26 deg	24 deg	50/240	16755

FW72 Lo-Lube 90mm Top Plate

Part Number	Height (A)	Assembly Weight	Oscillation		D-Rating kN	CRN Number
			B	C		
*FW72O	N/A	146 kg	Top Only		N/A	N/A
FW72OT	168 mm	165 kg	10 deg	N/A	90/270	16756
FW72OF	191 mm	167 kg	18 deg	16 deg	90/270	16756
FW72OA	201 mm	168 kg	20 deg	18 deg	90/270	16756
FW72OX	235 mm	172 kg	26 deg	24 deg	90/270	16756

* Top plate only - c/w foot pins and fixings

Note: All FW72 Fifth Wheel assemblies are supplied in LH Release as standard.

RH Release is available, use the suffix "R" when ordering this option. ie: FW72DT2 becomes FW72DT2R.

Specifications regarding heights and weights are nominal only. We reserve the right to make changes a necessary.



GO THE DISTANCE.

FIFTH WHEELS

FW72 Lo-Lube Cast Fifth Wheels On A Base Plate

CAST STEEL Construction to suit 50 & 90mm Kingpin.

All Fifth Wheel package: Tested to AS4968 series under requirements of ADR 62/01

FW72 Lo-Lube D rating: 50/D 2400 (50mm) & 90/D 270 (90 mm).

As configurations can change, please refer to the respective assembly or part no. for the correct & applicable D rating.

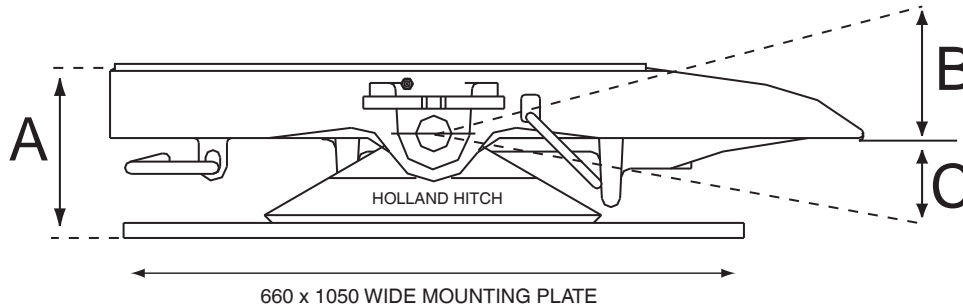

FW72 Lo-Lube 50mm Top Plate

Part Number	Height (A)	Base Plate Thickness	Assembly Weight	Oscillation B	Oscillation C	D-Rating kN	CRN Number
FW72DL2	162 mm	16 mm	250 kg	8 deg	8 deg	50/240	16642
FW72DL3	166 mm	20 mm	276 kg	8deg	8 deg	50/240	16647
FW72DT2	184 mm	16 mm	255 kg	10 deg	11 deg	50/240	16642
FW72DT3	188 mm	20 mm	282 kg	10 deg	11 deg	50/240	16647
FW72DF2	207 mm	16 mm	257 kg	16 deg	18 deg	50/240	16642
FW72DF3	211 mm	20 mm	284 kg	16 deg	18 deg	50/240	16647
FW72DA2	217 mm	16 mm	258 kg	20 deg	19 deg	50/240	16642
FW72DA3	221 mm	20 mm	285 kg	20 deg	19 deg	50/240	16647
FW72DX2	252 mm	16 mm	263 kg	26 deg	23 deg	50/240	16642
FW72DX3	256 mm	20 mm	290 kg	26 deg	23 deg	50/240	16647

FW72 Lo-Lube 90mm Top Plate

Part Number	Height (A)	Base Plate Thickness	Assembly Weight	Oscillation B	Oscillation C	D-Rating kN	CRN Number
FW72OL2	162 mm	16 mm	251 kg	8 deg	8 deg	90/270	16653
FW72OL2	166 mm	20 mm	277 kg	8 deg	8 deg	90/270	16660
FW72OT2	184 mm	16 mm	256 kg	10 deg	11 deg	90/270	16653
FW72OT3	188 mm	20 mm	283 kg	10 deg	11 deg	90/270	16660
FW72OF2	207 mm	16 mm	258 kg	16 deg	18 deg	90/270	16653
FW72OF3	211 mm	20 mm	285 kg	16 deg	18 deg	90/270	16660
FW72OA2	217 mm	16 mm	259 kg	20 deg	19 deg	90/270	16653
FW72OA3	221 mm	20 mm	286 kg	20 deg	19 deg	90/270	16660
FW72OX2	252 mm	16 mm	264 kg	26 deg	23 deg	90/270	16653
FW72OX3	256 mm	20 mm	291 kg	26 deg	23 deg	90/270	16660

Note: All FW72 Fifth Wheel assemblies are supplied in LH Release as standard.

RH Release is available, use the suffix "R" when ordering this option. ie: FW72DT2 becomes FW72DT2R.

Specifications regarding heights and weights are nominal only. We reserve the right to make changes a necessary.



FIFTH WHEELS

FW72 Lo-Lube Cast Fifth Wheels On A Single Row Ballrace Assembly

CAST STEEL Construction to suit 50 & 90mm Kingpin.

All Fifth Wheel package: Tested to AS4968 series under requirements of ADR 62/01

FW72 Lo-Lube D rating: 50/D 240 (50mm) & 90/D 270 (90 mm).

As configurations can change, please refer to the respective assembly or part no. for the correct & applicable D rating.

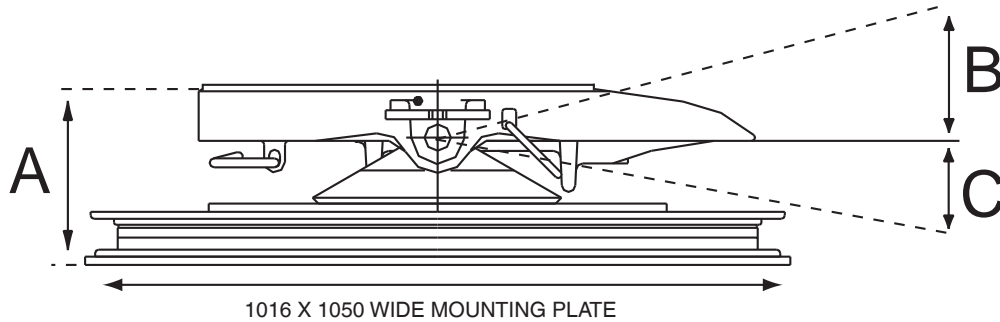

FW72 Lo-Lube 50mm Top Plate

Part Number	Height (A)	Base Plate Thickness	Assembly Weight	Oscillation		D-Rating kN	CRN Number
				B	C		
FW72DLS4	234 mm	16 mm	354 kg	15 deg	12 deg	50/190	16645
FW72DLS5	238 mm	20 mm	380 kg	15 deg	12 deg	50/190	16645
FW72DTS4	256 mm	16 mm	355 kg	16 deg	13 deg	50/190	16645
FW72DTS5	260 mm	20 mm	381 kg	16 deg	13 deg	50/190	16645
FW72DAS4	289 mm	16 mm	358 kg	21 deg	16 deg	50/190	16645
FW72DAS5	293 mm	20 mm	384 kg	21 deg	16 deg	50/190	16645

FW72 Lo-Lube 90mm Top Plate

Part Number	Height (A)	Base Plate Thickness	Assembly Weight	Oscillation		D-Rating kN	CRN Number
				B	C		
FW72OLS4	234 mm	16 mm	355 kg	15 deg	12 deg	90/190	16664
FW72OLS5	238 mm	20 mm	381 kg	15 deg	12 deg	90/190	16664
FW72OTS4	256 mm	16 mm	356 kg	16 deg	13 deg	90/190	16664
FW72OTS5	260 mm	20 mm	382 kg	16 deg	13 deg	90/190	16664
FW72OAS4	289 mm	16 mm	359 kg	21 deg	16 deg	90/190	16664
FW72OAS5	293 mm	20 mm	385 kg	21 deg	16 deg	90/190	16664

Note: All FW72 Fifth Wheel assemblies are supplied in LH Release as standard.

RH Release is available, use the suffix "R" when ordering this option. ie: FW72DT2 becomes FW72DT2R.

Specifications regarding heights and weights are nominal only. We reserve the right to make changes a necessary.



GO THE DISTANCE.

FIFTH WHEELS

FW72 Lo-Lube Cast Fifth Wheels On A Double Row Ballrace Assembly

Section 1 - 4d

CAST STEEL Construction to suit 50 & 90mm Kingpin.

All Fifth Wheel package: Tested to AS4968 series under requirements of ADR 62/01

FW72 Lo-Lube D rating: 50/D 240 (50mm) & 90/D 270 (90 mm).

As configurations can change, please refer to the respective assembly or part no. for the correct & applicable D rating.

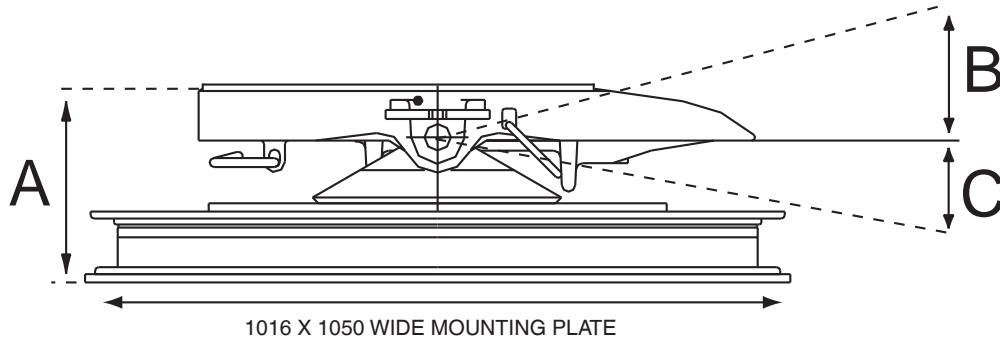

FW72 Lo-Lube 50mm Top Plate

Part Number	Height (A)	Base Plate Thickness	Assembly Weight	Oscillation		D-Rating kN	CRN Number
				B	C		
FW72DLD4	264 mm	16 mm	375 kg	15 deg	12 deg	50/240	16644
FW72DLD5	268 mm	20 mm	401 kg	15 deg	12 deg	50/240	16644
FW72DTD4	286 mm	16 mm	376 kg	16 deg	13 deg	50/240	16644
FW72DTD5	290 mm	20 mm	402 kg	16 deg	13 deg	50/240	16644
FW72DAD4	319 mm	16 mm	379 kg	21 deg	16 deg	50/240	16644
FW72DAD5	323 mm	20 mm	405 kg	21 deg	16 deg	50/240	16644

FW72 Lo-Lube 90mm Top Plate

Part Number	Height (A)	Base Plate Thickness	Assembly Weight	Oscillation		D-Rating kN	CRN Number
				B	C		
FW72OLD4	264 mm	16 mm	376 kg	15 deg	12 deg	90/270	16661
FW72OLD5	268 mm	20 mm	402 kg	15 deg	12 deg	90/270	16661
FW72OTD4	286 mm	16 mm	377 kg	16 deg	13 deg	90/270	16661
FW72OTD5	290 mm	20 mm	403 kg	16 deg	13 deg	90/270	16661
FW72OAD4	319 mm	16 mm	380 kg	21 deg	16 deg	90/270	16661
FW72OAD5	323 mm	20 mm	406 kg	21 deg	16 deg	90/270	16661

Note: All FW72 Fifth Wheel assemblies are supplied in LH Release as standard.

RH Release is available, use the suffix "R" when ordering this option. ie: FW72DT2 becomes FW72DT2R.

Specifications regarding heights and weights are nominal only. We reserve the right to make changes a necessary.



GO THE DISTANCE.

FIFTH WHEELS

Section 1 - 4e

FW72 Lo-Lube Cast Fifth Wheels On A Kompensator

CAST STEEL Construction to suit 50 & 90mm Kingpin.

All Fifth Wheel package: Tested to AS4968 series under requirements of ADR 62/01

FW72 Lo-Lube D rating: 50/D 240 (50mm) & 90/D 270 (90 mm).

As configurations can change, please refer to the respective assembly or part no. for the correct & applicable D rating.

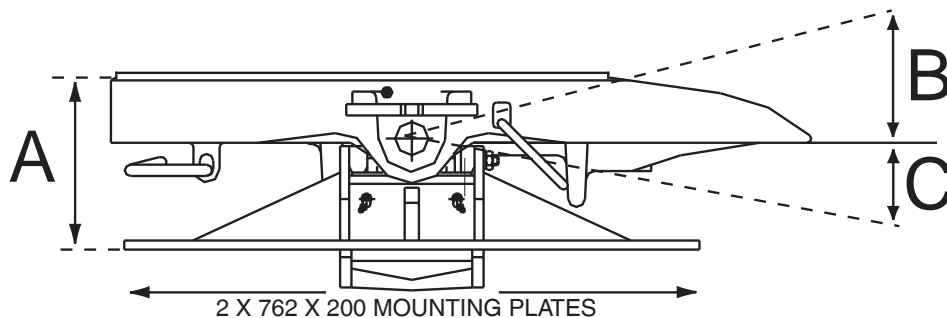

Part Number	Height (A)	Base Plate Thickness	Assembly Weight	Oscillation		D-Rating kN	CRN Number
				B	C		
FW72DK	243 mm	12 mm	276 kg	19 deg	16 deg	50/163	16648
FW72OK	243 mm	12 mm	277 kg	19 deg	16 deg	90/163	16667

FW72 Lo-Lube Cast Fifth Wheels On A Kompensator Full Plate

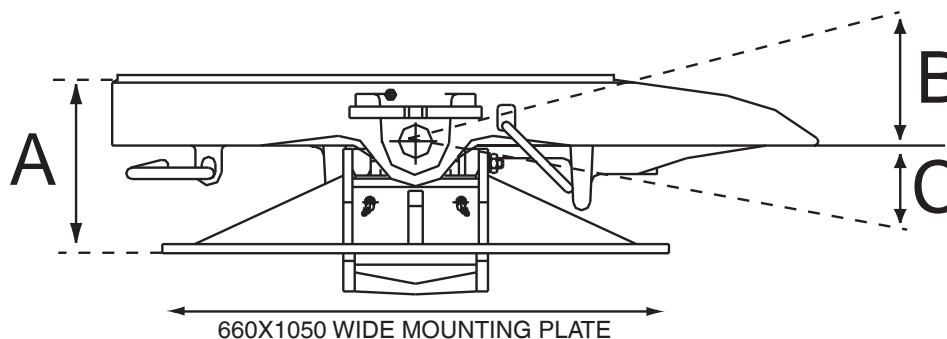

Part Number	Height (A)	Base Plate Thickness	Assembly Weight	Oscillation		D-Rating kN	CRN Number
				B	C		
FW72DKP	243 mm	12 mm	297 kg	19 deg	16 deg	50/163	16795
FW72DKP6	247 mm	16 mm	317 kg	19 deg	16 deg	50/163	16795
FW72DKP7	251 mm	20 mm	334 kg	19 deg	16 deg	50/163	16795
FW72OKP	243 mm	12 mm	298 kg	19 deg	16 deg	90/163	16796
FW72OKP6	247 mm	16 mm	318 kg	19 deg	16 deg	90/163	16796
FW72OKP7	251 mm	20 mm	335 kg	19 deg	16 deg	90/163	16796

Note: Kompensator Allows 5 degree of oscillation either side of vertical centre line. Centre of gravity not to exceed 1120mm above Fifth Wheel Top Plate Surface.

All FW72 Fifth Wheel assemblies are supplied in LH Release as standard.

RH Release is available, use the suffix "R" when ordering this option. ie: FW72DT2 becomes FW72DT2R.

Specifications regarding heights and weights are nominal only. We reserve the right to make changes as necessary.



GO THE DISTANCE.

FIFTH WHEELS

FW72 Lo-Lube Cast Fifth Wheels On A Single Row Ballrace/ Kompensator

CAST STEEL Construction to suit 50 & 90mm Kingpin.

All Fifth Wheel package: Tested to AS4968 series under requirements of ADR 62/01

FW72 Lo-Lube D rating: 50/D 240 (50mm) & 90/D 270 (90 mm).

As configurations can change, please refer to the respective assembly or part no. for the correct & applicable D rating.

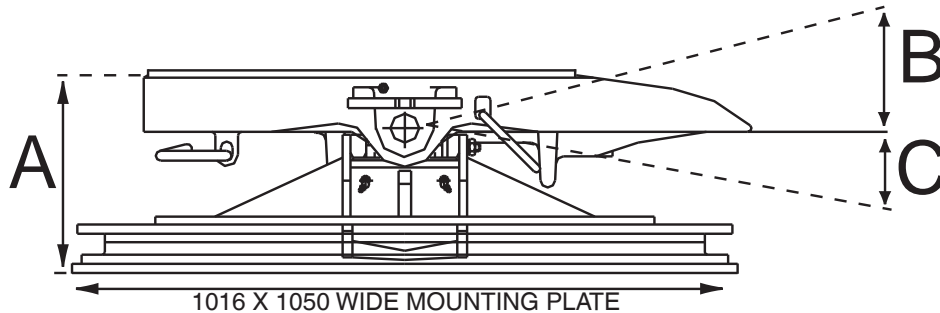

Part Number	Height (A)	Base Plate Thickness	Assembly Weight	Oscillation B	Oscillation C	D-Rating kN	CRN Number
FW72DKS4	294 mm	16 mm	433 kg	19 deg	16 deg	50/163	16649
FW72DKS5	298 mm	20 mm	459 kg	19 deg	16 deg	50/163	16649
FW72OKS4	294 mm	16 mm	434 kg	19 deg	16 deg	90/163	16663
FW72OKS5	298 mm	20 mm	460 kg	19 deg	16 deg	90/163	16663

FW72 Lo-Lube Cast Fifth Wheels On A Double Row Ballrace/Kompensator

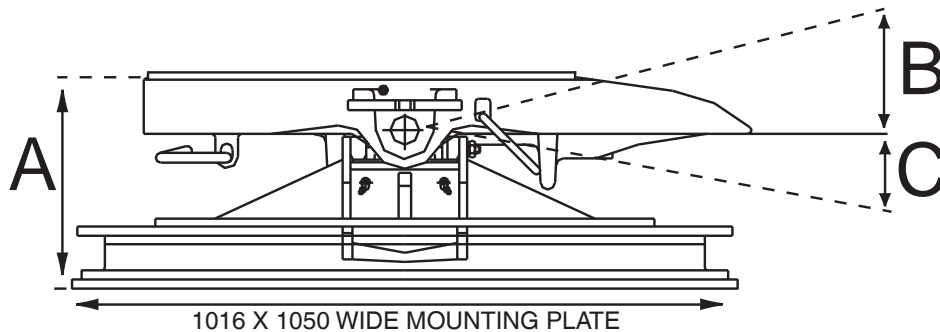

Part Number	Height (A)	Base Plate Thickness	Assembly Weight	Oscillation B	Oscillation C	D-Rating kN	CRN Number
FW72DKD4	324 mm	16 mm	453 kg	19 deg	16 deg	50/163	16646
FW72DKD5	328 mm	20 mm	478 kg	19 deg	16 deg	50/163	16646
FW72OKD4	324 mm	16 mm	454 kg	19 deg	16 deg	90/163	16662
FW72OKD5	328 mm	20 mm	479 kg	19 deg	16 deg	90/163	16662

Note: Kompensator Allows 5 degree of oscillation either side of vertical centre line. Centre of gravity not to exceed 1120mm above Fifth Wheel Top Plate Surface.

All FW72 Fifth Wheel assemblies are supplied in LH Release as standard.

RH Release is available, use the suffix "R" when ordering this option. ie: FW72DT2 becomes FW72DT2R.

Specifications regarding heights and weights are nominal only. We reserve the right to make changes as necessary.



GO THE DISTANCE.

FIFTH WHEELS

FW72 Lo-Lube Cast Fifth Wheel Slider Options

Section 1 - 4g

CAST STEEL Construction to suit 50 & 90mm Kingpin.

All Fifth Wheel package: Tested to AS4968 series under requirements of ADR 62/D1

FW72 Lo-Lube D rating: 50/D 240 (50mm) & 90/D 270 (90 mm).

As configurations can change, please refer to the respective assembly or part no. for the correct & applicable D rating.

Heavy Duty Air Slider Fixed

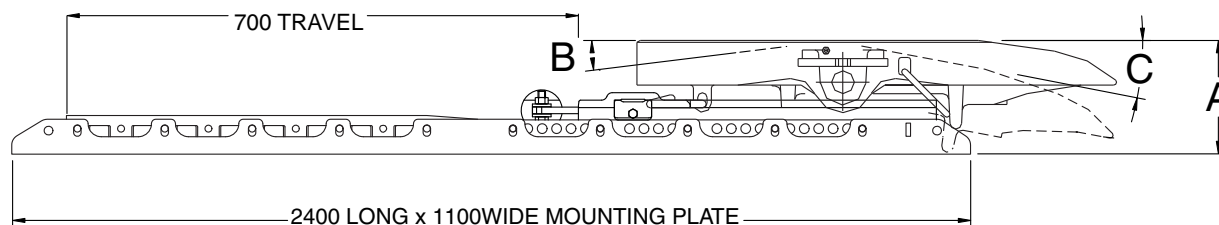

FW72 Lo-Lube 50mm Top Plate

Part Number	Height (A)	Assembly Weight	Oscillation B	Oscillation C	Travel Length	D-Rating kN	CRN Number
FWS72DL	186 mm	434 kg	8 deg	8 deg	700 mm	50/240	TBA
FWS72DT	208 mm	439 kg	10 deg	11 deg	700 mm	50/240	TBA
FWS72DF	231 mm	441 kg	18 deg	16 deg	700 mm	50/240	TBA
FWS72DA	241 mm	442 kg	20 deg	18 deg	700 mm	50/240	TBA
FWS72DX	275 mm	447 kg	26 deg	24 deg	700 mm	50/240	TBA

FW72 Lo-Lube 90mm Top Plate

Part Number	Height (A)	Assembly Weight	Oscillation B	Oscillation C	Travel Length	D-Rating kN	CRN Number
FWS72OL	186 mm	435 kg	8 deg	8 deg	700 mm	90/270	TBA
FWS72OT	208 mm	440 kg	10 deg	11 deg	700 mm	90/270	TBA
FWS72OF	231 mm	442 kg	18 deg	16 deg	700 mm	90/270	TBA
FWS72OA	241 mm	443 kg	20 deg	18 deg	700 mm	90/270	TBA
FWS72OX	275 mm	448 kg	26 deg	24 deg	700 mm	90/270	TBA

Note: All FW72 Fifth Wheel assemblies are supplied in LH Release as standard.

RH Release is available, use the suffix "R" when ordering this option. ie: FW72DT2 becomes FW72DT2R.

Specifications regarding heights and weights are nominal only. We reserve the right to make changes a necessary.



GO THE DISTANCE.

FIFTH WHEELS

FW72 Lo-Lube Cast Fifth Wheel Slider Options cont...

CAST STEEL Construction to suit 50 & 90mm Kingpin.

All Fifth Wheel package: Tested to AS4968 series under requirements of ADR 62/D1

FW72 Lo-Lube D rating: 50/D 240 (50mm) & 90/D 270 (90 mm).

SR 60/1000 Rating D/190

DR 90/1000 Rating D/270

As configurations can change, please refer to the respective assembly or part no. for the correct & applicable D rating.

Heavy Duty Air Slider Ballrace

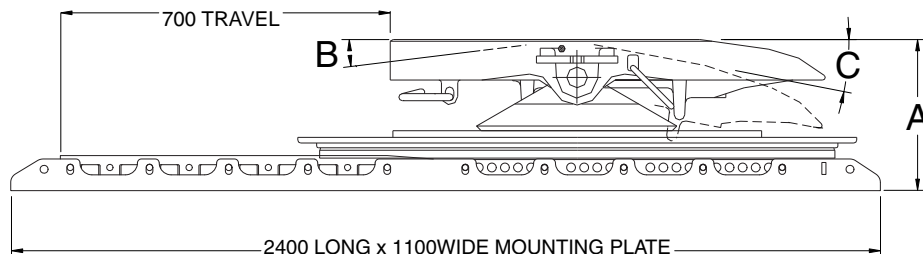

FW72 Lo-Lube 50mm Top Plate

Part Number	Height (A)	Assembly Weight	Oscillation		Travel Length	D-Rating kN	CRN Number
			B	C			
FWS72DLS	255 mm	600 kg	15 deg	12 deg	700 mm	50/190	TBA
FWS72DTS	277 mm	601 kg	16 deg	13 deg	700 mm	50/190	TBA
FWS72DLD	285 mm	621 kg	15 deg	12 deg	700 mm	50/240	TBA
FWS72DTD	307 mm	622 kg	16 deg	13 deg	700 mm	50/240	TBA

FW72 Lo-Lube 90mm Top Plate

Part Number	Height (A)	Assembly Weight	Oscillation		Travel Length	D-Rating kN	CRN Number
			B	C			
FWS72OLS	255 mm	601 kg	15 deg	12 deg	700 mm	90/190	TBA
FWS72OTS	277 mm	602 kg	16 deg	13 deg	700 mm	90/190	TBA
FWS72OLD	285 mm	622 kg	15 deg	12 deg	700 mm	90/270	TBA
FWS72OTD	307 mm	623 kg	16 deg	13 deg	700 mm	90/270	TBA

Note: All FW72 Fifth Wheel assemblies are supplied in LH Release as standard.

RH Release is available, use the suffix "R" when ordering this option. ie: FW72DT2 becomes FW72DT2R.

Specifications regarding heights and weights are nominal only. We reserve the right to make changes a necessary.



GO THE DISTANCE.

FIFTH WHEELS

FW72 Lo-Lube Handle Option

Section 1 - 4i

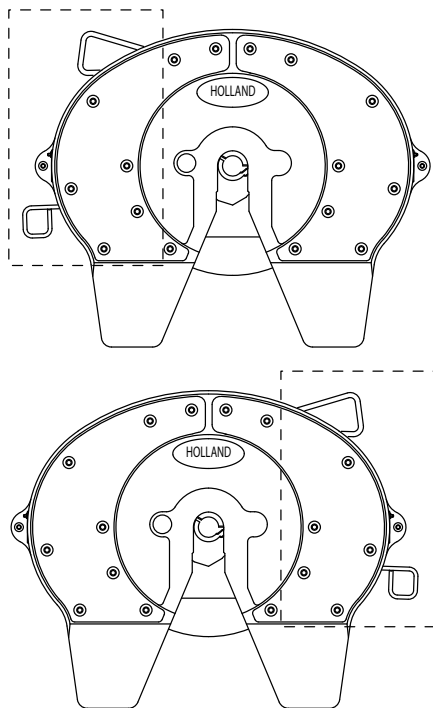

RH Release Handle

When ordering a "RH Release handle option, add suffix "R" to the fifth wheel part number. eg: FW72DTR.

This attracts the same CRN and number as the standard LH Release models.

Note: All FW72 Fifth Wheel assemblies are supplied in LH Release as standard.
RH Release is available, use the suffix "R" when ordering this option. ie: FW72DT2 becomes FW72DT2R.
Specifications regarding heights and weights are nominal only. We reserve the right to make changes a necessary.



GO THE DISTANCE.

KOMPENSATOR

D Rating: 163 kN

The Kompensator is a patented speciality fifth wheel designed for use with torsionally rigid trailers such as liquid and dry bulk tankers.

The only fifth wheel in the world with unique 'kompensation' to help reduce frame and tank damage.

GO THE DISTANCE.

CAST STEEL Construction to suit FW351, FW342, FW70 & FW72 top plates.

All Fifth Wheel packages: Tested to AS4968 series under requirements of ADR 62/O1

Kompensator D rating: 163

As configurations can change, please refer to the respective assembly or part no. for the correct & applicable D rating.

KOMPENSATOR - MOUNTING PLATES

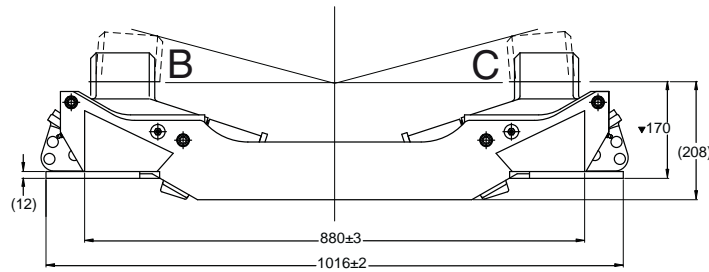

Kompensator on 2 x 762 x 200 side plates suitable for bolting to chassis angles

Part Number	Weight	Oscillation		D-Rating kN
		B	C	
K	131 kg	5 deg	5 deg	163 kN

KOMPENSATOR - FULL PLATE

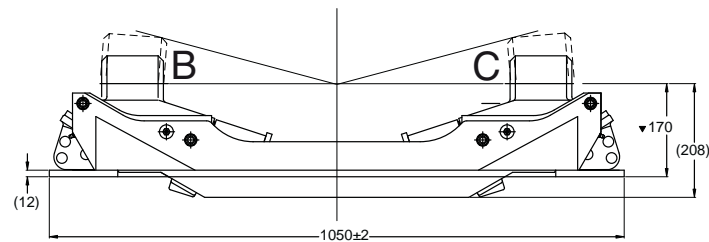

Kompensator on 1 x 1050 x 660 chassis mounting plate

Part Number	Base Plate	Weight	Oscillation		D-Rating kN
			B	C	
KP	12mm	153 kg	5 deg	5 deg	163 kN
KP6	16mm	174 kg	5 deg	5 deg	163 kN
KP7	20mm	201 kg	5 deg	5 deg	163 kN

KOMPENSATOR - SUIT BALLRACE

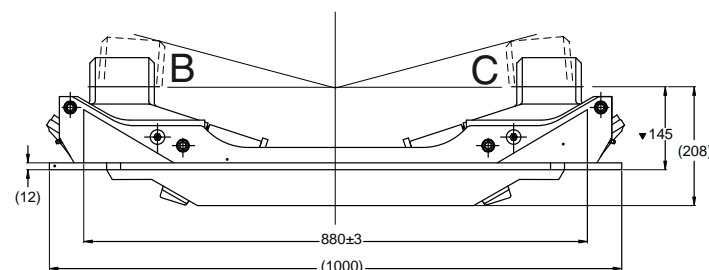

Kompensator on radiused mounting plate to suit ballrace mount

Part Number	Base Plate	Weight	Oscillation		D-Rating kN
			B	C	
KR	12mm	142 kg	5 deg	5 deg	163 kN



GO THE DISTANCE.

BALLRACE

The Holland SR & DR Ballraces are specifically manufactured to our exacting requirements to suit our Fifth Wheel applications



GO THE DISTANCE.

BALLRACE

Single Row Ballrace

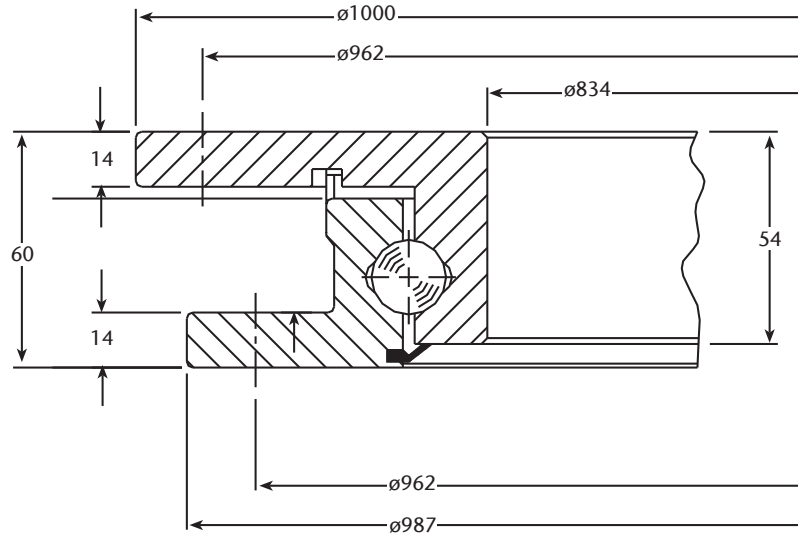

Part Number		Weight	D-Rating kN
SR601000	Undrilled	68 kg	190
SR601000D	Drilled	68 kg	190

Double Row Ballrace

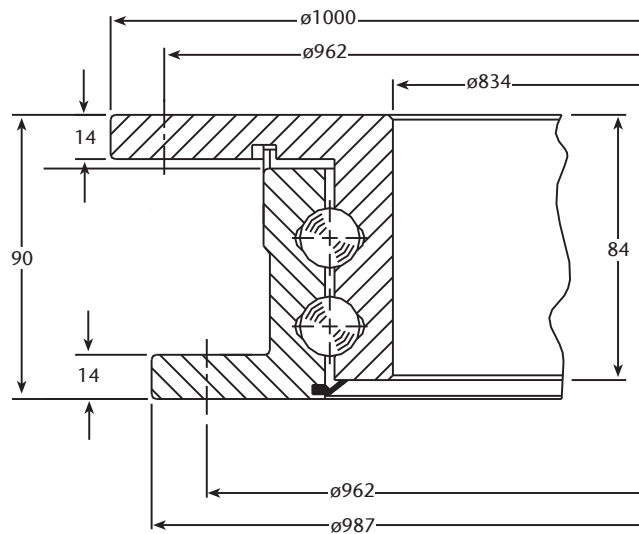

Part Number		Weight	D-Rating kN
DR901000	Undrilled	89 kg	270
DR901000D	Drilled	89 kg	270



GO THE DISTANCE.

BALLRACE

Double Row Ballrace

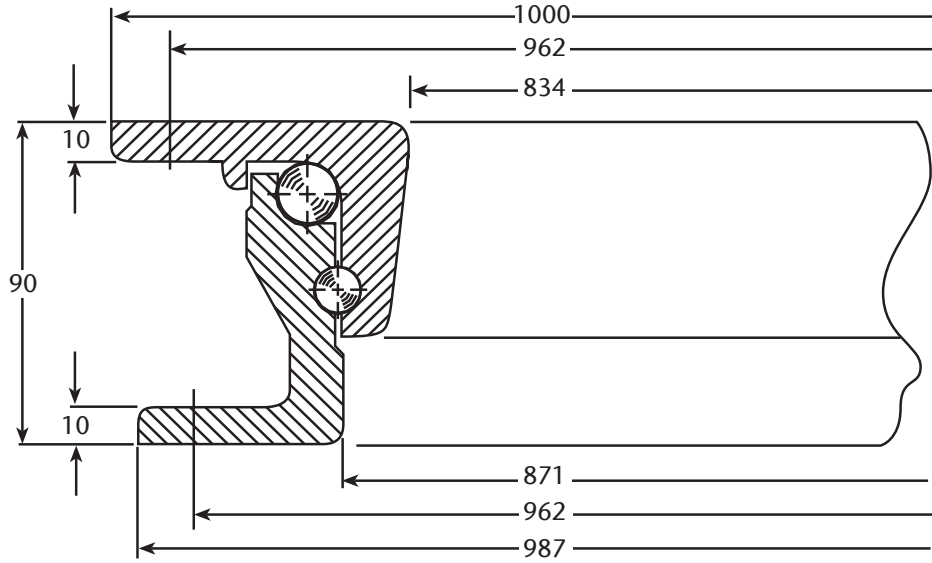

Part Number		Weight	D-Rating kN
90S1000	Undrilled	72 kg	190



GO THE DISTANCE.

SPECIAL APPLICATION

Off Road
Special Application

Heavy Duty Semi Oscillating
Fully Oscillating
Elevating



GO THE DISTANCE.

OFF ROAD SPECIAL APPLICATION FIFTH WHEELS

Section 1 - 7a

Heavy Duty Semi Oscillating

Cast Steel Weld-on Feet
Semi-Oscillating.

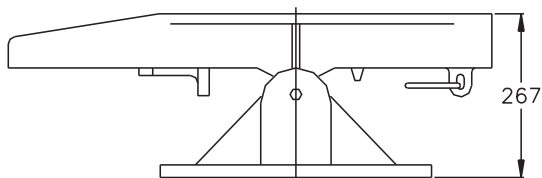

Part Number	Locks	Max Vertical Load	Max Drawbar Pull	Weight	D-Rating kN	CRN Number
FW165O	90 mm	75,000 kg	120,000 kg	270 kg	270	36513

Heavy Duty Fully Oscillating

Cast Steel Bolt-on Feet
Universal Fully Oscillating with Side Restriction.

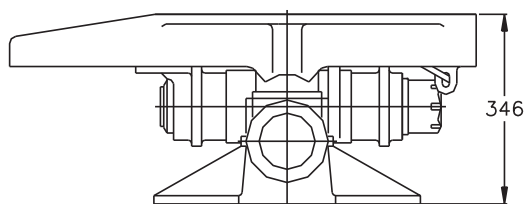

Part Number	Locks	Max Vertical Load	Max Drawbar Pull	Weight	D-Rating kN	CRN Number
FW2080D	50 mm	32,000 kg	120,000 kg	370 kg	N/A	TBA
FW2080O	90 mm	32,000 kg	120,000 kg	370 kg	270	36513



GO THE DISTANCE.

OFF ROAD ELEVATING FIFTH WHEELS

Single Hydraulic Ram

Elevating Fifth Wheel
Suits 50mm King Pin

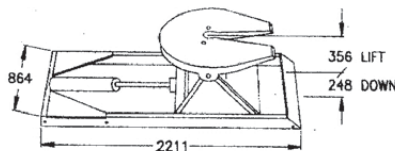

Includes Oil Tank & Filter, & Cab Switch for Jaw release.
P.T.O., Pump, Hydraulic Hoses & Raise/Lower Control to be supplied at Extra Cost at installation.

Includes Oil Tank And Filter, & Cab Switch for Jaw release.
PTO, Pump Hydraulic Hoses & Raise/Lower Control to be supplied at extra cost at installation

Part Number	Lifting Capacity	Weight	D-Rating kN	CRN Number
FW2900X	23,000 kg	702 kg	N/A	N/A

Twin Hydraulic Ram

Elevating Fifth Wheel
Suits 50mm King Pin

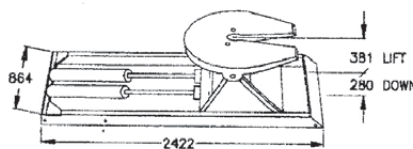

Includes Oil Tank & Filter, & Cab Switch for Jaw release.
P.T.O., Pump, Hydraulic Hoses & Raise/Lower Control to be supplied at Extra Cost at installation.

Includes Oil Tank And Filter, & Cab Switch for Jaw release.
PTO, Pump Hydraulic Hoses & Raise/Lower Control to be supplied at extra cost at installation

Part Number	Lifting Capacity	Weight	D-Rating kN	CRN Number
FW29005X	45,000 kg	887 kg	N/A	N/A

Air Elevating

Fifth Wheel
Suits 50mm King Pin

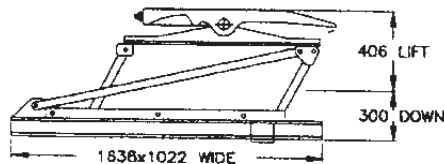

Part Number	Lifting Capacity	Weight	D-Rating kN	CRN Number
FW6716B	18,000 kg	905 kg	N/A	N/A



GO THE DISTANCE.

PARTS

Rocker Brackets
Bushes
Service Kits
FW3500 Top Plates
pro-hitch 351 Top Plates
pro-hitch 342 Top Plates
FW70 Top Plates
FW72 Top Plates
FW2080 Top Plates
Kompensator
Service Tools



FIFTH WHEELS PARTS

Cast Steel Weld On Rocker Brackets

GO THE DISTANCE.

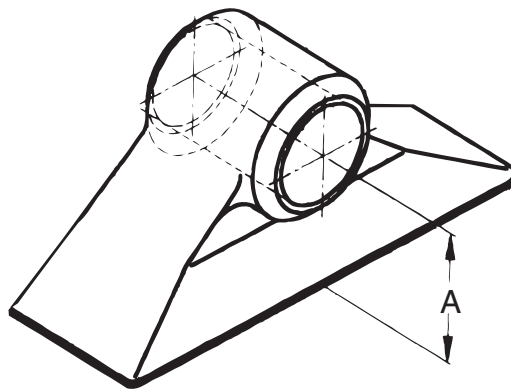

To suit FW3500, pro-hitch 351 & FW70 Fifth Wheel Top Plates

Part Number	Height (A)	Assembly Weight
XB2007HL	73	6.9kg
XB2007HT	95	10.4kg
XB2007HF	118	10.5kg
XB2007HA	128	11.7kg
XB2007HX	163	13.3kg

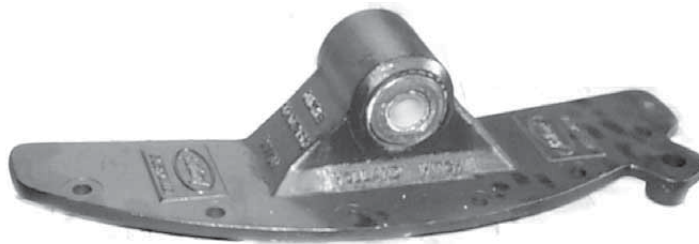

Part Number	Height (A)	Assembly Weight
XB2007HB	85	16.8kg
XB2007HD	107	22.8kg
XB2007HE	140	22kg



FIFTH WHEELS PARTS

Rocker Bracket Bushes

GO THE DISTANCE.

***XB16045P**

To Suit FW3500 series & pro-hitch 351 series.

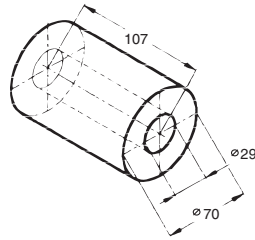

***XB16049USAP**

To Suit
FW70 series
(Fabricated Rocker Brackets
only up to Dec '98)

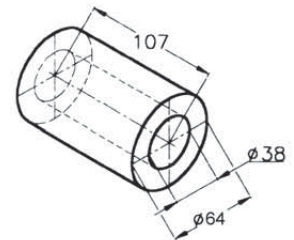

***XB16049AUSP**

Heavy Duty Bush
FW70 series
(Cast Rocker Brackets Only)
Polyurethane

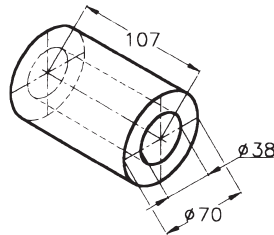

***XB0012P**

To Suit
FW70 Kompensator series
Polyurethane.

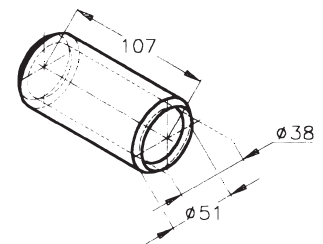

***XB0011P**

Heavy Duty Bush
FW3500 & pro-hitch 351
Kompensator series
Polyurethane

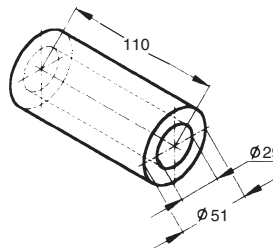

XB00113

To Suit
ISO bolt on foot &
sliding fifth wheel
assembly

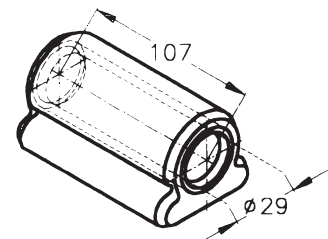

Note: * Bushes available in kits only.
Please be aware that the RK16045J compression bush is superseded by the RK16045P; blue polyurethane bush.



FIFTH WHEELS PARTS

Foot Pins

GO THE DISTANCE.

Section 1 - 8c

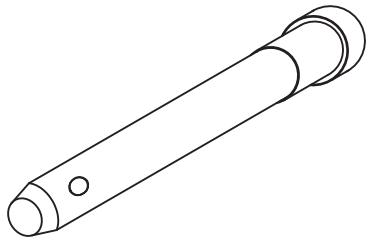

XA2016 Foot Pin FW350

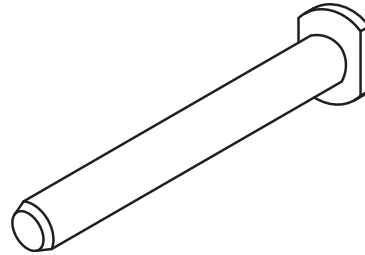

XE06356 Foot Pin FW351

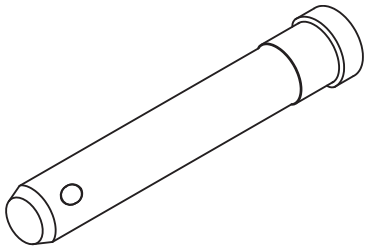

XB2632 FW70 Foot Pin
Old style

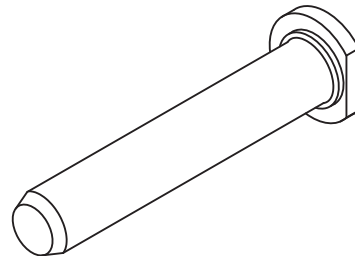

XE02759 Foot Pin FW70
Current style

* Pins available in kits only.



FIFTH WHEELS PARTS

FW3500

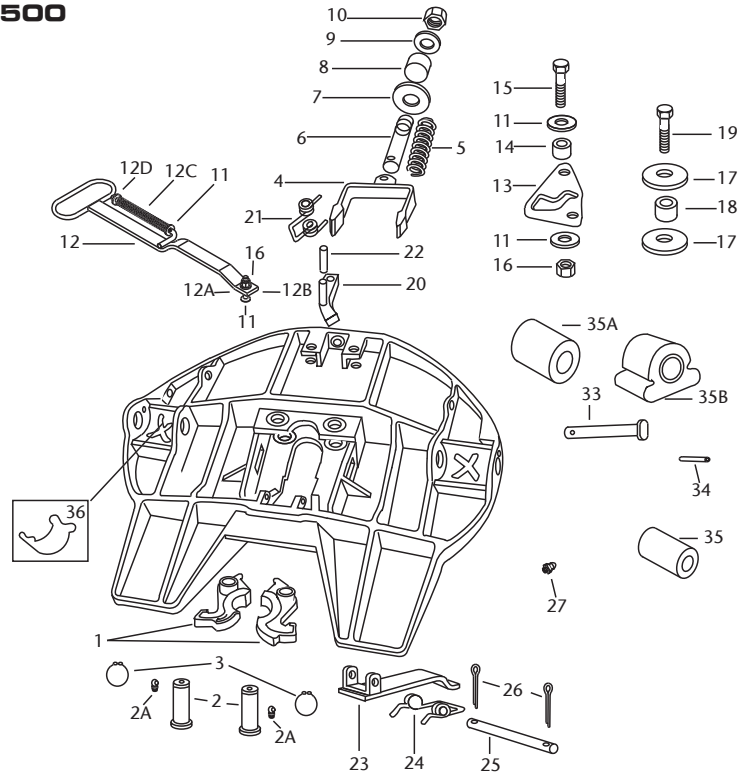

Item	Part No.	Description	Qty	Item	Part No.	Description	Qty
1*	XA1704	Lock Jaws	1	15	XB1021	Bolt 1/2"-20 x 1 3/4"	1
2*	XA1313H	Jaw Pin	2	16	XBT69A	Locknut 1/2"- 20	1
2A	XBH38A	Grease Nipple 90	2	17*	XB10301	Washer	2
3*	XB5A	Circlip	2	18*	XA1507	Roller	1
4*	XA1703F	Yoke sub-assembly	1	19	XBCX58F134	Bolt 5/8"-18 x 1.3/4"	1
5*	XB1505	Spring	1	20*	XA3542R	Secondary Lock, Right Hand	1
6*	XA1706	Yoke Shaft	1	21*	XB2149	Torsion Spring	1
7*	XB02312	Lock Adjustment Tag	1	22	XB2155002750	Roll Pin	1
8*	XB1127	Rubber Washer	1	23*	XA3514	Lock guard	1
9*	XPW1316112	Washer 1 1/2" O.D x 13/16" I.D.	1	24*	XB1044	Torsion Spring	1
10	XBH1127	Locknut 3/4"-16	1	25*	XA1055	Pin	1
11	XBT49	Washer 1 3/4" O.D.x 9/16" I.D.	4	26	XB16	Cotter Pin 1/8" x 1 1/2"	2
12	XA1707D	D-Ring Release Handle	1	27	XBH38	Grease Nipple	2
12A*	XA102911	Roller 1/2" I.D.x 7/16" T.H.K.	1	33*	XA2016	Foot Pin	2
12B	XB12FC5K134	Bolt 1/2"x 1 3/4" C.S.K. H.D.	1	34*	XB2153751750	Roll Pin	2
12C	XB10281	Spring Handle	1	35*	XB0011P	Foot Bush (Poly) Komp	2
12D*	XPW17321116	Washer	1	35A*	XB16045P	Foot Bush (Poly)	2
13*	XA1705C	Cam Plate	1	35B*	XB00113	Foot Bush (Slider bracket only)	2
14*	XA1029	Roller	1	36	DOGBONE	DOGBONE wear pads - pair (optional)	1

* Only available as part of a kit.



FIFTH WHEELS PARTS

Service Kits
FW3500

GO THE DISTANCE.

Section 1 - 8e

Part Number	Description	Item Number	Required Parts	Qty
RK2016	Holland Pin Pack	33	XA2016	2
		34	XB21S3751750	2
RK16045P	Holland Bush Pack Poly	35A	XB16045P	2
RK1707D	D-Ring Release Handle Kit 3500	11	XBT49	2
		12	XA1707D	1
		12A	XA102911	1
		12B	XB12FCSK134	1
		12C	XB10281	1
		12D	XBPW17321116	1
		16	XBT69A	1
RK2016P	Pin & Bush Kit c/w Poly Bush	33	XA2016	2
		34	XB21S3751750	2
		35A	XB16045P	2
RK0011P	Holland Bush Pack FW3540	35	XB0011P	2
RK63501	3500 Series Rebuild Kit	1-27	Inclusive	
RK63503A	3500 Series Jaw Kit Complete with Yoke	1	XA1704	1
		2	XA1313H	2
		2A	XBH38A	2
		3	XB5A	2
		4	XA1703F	1
		19	XBCX58F134	1
RK63504	3500 Series Mini Rebuild Kit	1	XA1704	1
		2	XA1313H	2
		2A	XBH38A	2
		3	XB5A	2
		4	XA1703F	1
		19	XBCX58F134	1
		33	XA2016	2
		34	XB21S3751750	2
		35A	XB16045P	2
RK1705C	Cam Plate Replacement Kit	11	XBT49	2
		13	XA1705C	1
		14	XA1029	1
		15	XB1021	1
		16	XBT69A	1
		17	XB10301	2
		18	XA1507	1
		19	XBCX58F134	1



FIFTH WHEELS PARTS

Service Kits
FW3500

Part Number	Description	Item Number	Required Parts	Qty
RK3542R	Secondary Lock Replacement Kit	12	XB2149	1
		13	XB21S5002750	1
		14	XA3542R	1
RK3514	Lock Guard Replacement Kit	23	XA3514	1
		24	XB1044	1
		25	XA1055	1
		26	XB16	2
RK1706	Yoke Shaft Replacement Kit	5	XBH34F	1
		6	XPW1316112	1
		7	XB1127	1
		8	XB02312	1
		9	XA1706	1
		10	XB1505	1



FIFTH WHEELS PARTS

pro-hitch 351

GO THE DISTANCE.

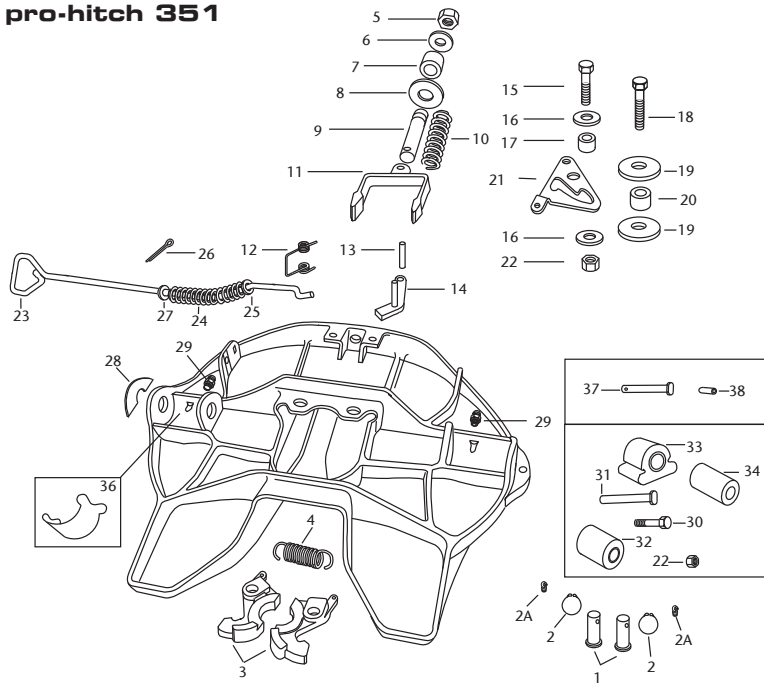

Item	Part No.	Description	Qty	Item	Part No.	Description	Qty
1*	XA0729282	Lock Pin	2	19*	XB07431	Washer 67 X 17 (2-5/8" x 21/32")	2
2	XB07398	Circlip	2	20*	XA1507	Roller 16mm (5/8" I.D.)	1
2A	XBH38A	Grease Nipple 90°	2	21*	XA07150R	Cam Plate (Right-hand)	1
3*	XA07296	Lock Jaw Set	1		XA07150L	Cam Plate (Left-hand)	1
4*	XB07628	Extension Spring	1		(optional)		
5	XBHNH34F	Locknut 19.05mm (3/4" 16)	1	22	XBT69A	Locknut 12mm (1/2"-20)	2
6*	XPW1316112	Washer 38 X 20mm (1 1/2" O.D. X 13/16" I.D.)	1	23*	XA071511	Release Handle	1
7*	XB1127	Rubber Washer	1	24	XB07291	Compression Spring	1
8*	XB02312	Lock Adjustment	1	25	XPW17321116	Washer (1-1/16" O.D x 9/16" I.D)	1
9*	XA1706	Yoke Shaft	1	26*	XB07508	Cotter Pin (1/8"x1-1/4")	1
10*	XB1505	Compression Spring	1	27	XBT49	Washer (1-3/8" O.D x 9/16" I.D)	1
11*	XA07295	Yoke	1	28	XB07610	Operation Tag	1
	XA07295THK	Yoke, Thick (Optional)		29	XBH38	Grease Nipple 90°	2
12*	XB2149	Torsion Spring	1	30	XBC95	Hex Head Cap Screw (1/2"- 20 X1-1/4")	2
13	XB21S5002750	Roll Pin 12mmx70 (1/2"x2-3/4")	1	31*	XE06356	Foot Pin	2
14*	XA3542R	Secondary Lock (Righ-hand)	1	32*	XB16045P	Foot Bush (Poly)	2
	XA3542L	Secondary Lock (Left-hand) (optional)	1	33	XB00113	Foot Bush (Slider Bracket Only)	2
15	XB1021	Hex Head Cap Screw 12mm X 44 (1/2"-20x1-3/4")	1	34*	XB0011P	Foot Bush (Poly) (Komp)	2
16*	XB08559	Washer 44 X14 (1-3/4" O.D. X 9/16" I.D)	2	36	DOGBONE	Wear pads - pair (optional)	1
17*	XA1029	Roller 12mm (1/2" I.D.)	1	37*	XA2016	Foot Pin	2
18	XBCX58F134	Hex Head Cap Screw 16 X 44 (5/8"-18x1-3/4")	1	38*	XB21S3751750	Roll Pin	2

* Only available as part of a kit.



FIFTH WHEELS PARTS

Service Kits
pro-hitch 351

Part Number	Description	Item Number	Required Parts	Qty
RK351A	Standard Rebuild Kit pro-hitch 351	1-29	Inclusive	
RK0011P	Holland Bush Pack (Poly) Komp	34	XB0011P	2
RK07150R	Cam Plate Kit	15	XB1021	1
		16	XB08559	2
		17	XA1029	1
		18	XBCX58F138	1
		19	XB07431	2
		20	XA1507	1
		21	XA07150R	1
		22	XBT69A	1
RK35503A	Jaw Replacement Kit c/w Yoke	1	XA0729282	2
		2	XB07398	2
		2A	XBH38A	2
		3	XA07296	1
		4	XB07628	1
		11	XA07295	1
		18	XBCX58F134	1
RK35504	Mini Rebuild Kit includes Foot Pins & Bushes	1	XA0729282	2
		2	XB07398	2
		2A	XBH38A	2
		3	XA07296	1
		4	XB07628	1
		11	XA07295	1
		18	XBCX58F134	1
		22	XBT69A	2
		30	XBC95	2
		31	XE06356	2
		32	XB16045P	2
RK06356	Holland Pin Pack pro-hitch 351	22	XBT69A	2
		30	XBC95	2
		31	XE06356	2
RK06356P	Pin & Bush Kit c/w Poly Bush	22	XBT69A	2
		30	XBC95	2
		31	XE06356	2
		32	XB16045P	2



FIFTH WHEELS PARTS

Service Kits
pro-hitch 351

Part Number	Description	Item Number	Required Parts	Qty
RK1706	Yoke Shaft Replacement Kit	5	XBHNH34F	1
		6	XBPW1316112	1
		7	XB1127	1
		8	XB02312	1
		9	XA1706	1
		10	XB1505	1
RK2016	Holland Pin Pack	37	XA2016	2
		38	XB21S3751750	2
RK16045P	Holland Bush Pack	32	XB16045P	2
RK3542R	Secondary Lock Replacement Kit	12	XB2149	1
		13	XB21S5002750	1
		14	XA3542R	1
RK071511	Release Handle Kit	23	XA071511	1
		24	XB07291	1
		25	XBPW17321116	1
		26	XB07508	1
		27	XBT49	1
RK0729282	Lock Pin Replacement Set	1	XA0729282	2
		2	XB07398	2
		2A	XBH38A	2
RK35504THK	Min, Rebuild Kit, Thick Yoke	1	XA0729282	2
		2	XB07398	2
		2A	XBH38A	2
		3	XA07296	1
		4	XB07628	1
		11	XA07295THK	1
		18	XBCX58F134	1
		22	XBT69A	2
		30	XBC95	2
		31	XE06356	1
		32	XB16045P	2



GO THE DISTANCE.

FIFTH WHEELS PARTS

LowLube FW342

Section 1 - 8j

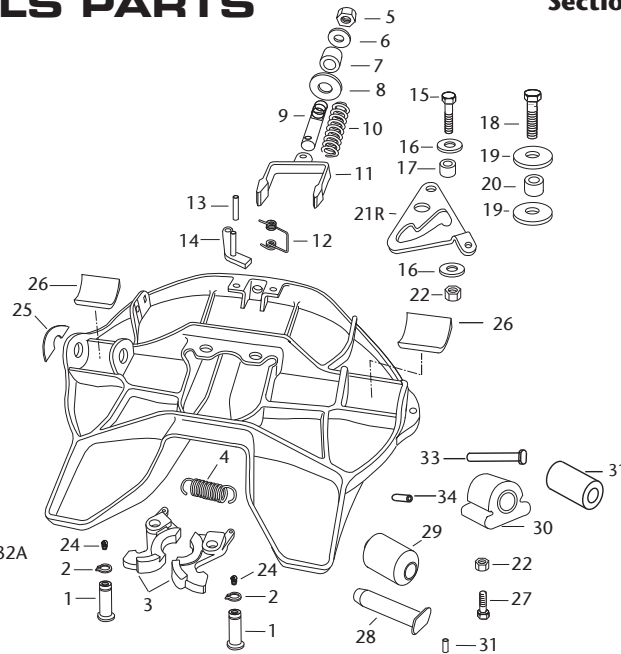
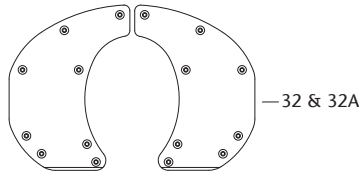
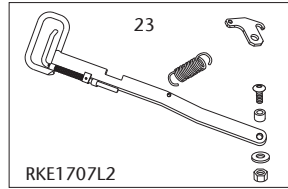
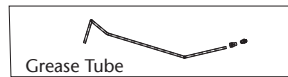

Item	Part No.	Description	Qty	Item	Part No.	Description	Qty
1*	XA0729282	Lock Pin	2	18	XBCX58F134	Hex Head Cap Screw 16 X 44 (5/8"-18x1-3/4")	1
2	XB07398	Circlip	2	19*	XB07431	Washer 67 X 17 (2-5/8"x 21/32")	2
3*	XA07296	Lock Jaw Set	1	20*	XA1507	Roller 16mm (5/8" I.D.)	1
4*	XB07628	Extension Spring	1	21R*	XA07150R	Cam Plate (Right-hand)	1
5	XBHNH34F	Locknut 19.05mm (3/4"16)	1	21L	XA07150L	Cam Plate (Left-hand) (optional)	1
6*	XPBW1316112	Washer 38 X 20mm (1 1/2" O.D. X13/16" I.D.)	1	22	XBT69A	Locknut 12mm (1/2"-20)	1
7*	XB1127	Rubber Washer	1	23	RKE1707L2	Release Handle	1
8*	XB02312	Lock Adjustment	1	24	XB38A	Grease Nipple 90°	2
9*	XA1706	Yoke Shaft	1	25	XB07610	Operation Tag	1
10*	XB1505	Compression Spring	1	26*	XB10210	Pocket Insert	2
11*	XA07295	Yoke	1	27	XBC95	Hex Head Cap Screw (1/2"- 20 X1-1/4")	2
	XA07295THK	Yoke Thick Tips		28*	XE06356	Foot Pin	2
12*	XB2149	Torsion Spring	1	29*	XB16045P	Foot Bush (Poly)	2
13	XB21S5002750	Roll Pin 12mmx70 (1/2"x2-3/4")	1	30	XB00113	Foot Bush (Slider Bracket Only)	2
14*	XA3542R	Secondary Lock (Righ-hand)	1	31*	XB0011P	Foot Bush (Poly) (Komp)	2
	XA3542L	Secondary Lock (Left-hand) (optional)	1	32	450411	Insert Set (pair) c/w fixings 3 or 4 Bolt	1
15	XB1021	Hex Head Cap Screw 12mm X 44 (1/2"-20x1-3/4")	1	32A	2501510	Insert Set (pair) c/w fixings 8 or 9 Bolt	1
16*	XB08559	Washer 44 X14 (1-3/4" O.D. X 9/16" I.D.)	2	33*	XA2016	Foot Pin (old style)	2
17*	XA1029	Roller 12mm (1/2" I.d.)	1	34*	XB21S3751750	Roll Pin	2
18	XBCX58F134	Hex Head Cap Screw 16 X 44 (5/8"-18x1-3/4")	1				

* Only available as part of a kit.



FIFTH WHEELS PARTS

LowLube FW342

Section 1 - 8k

GO THE DISTANCE.

Part Number	Description	Item Number	Required Parts	Qty
RK0011P	Holland Bush Pack (Poly) Komp	31	XB0011P	2
RK07150R	Cam Plate Kit	15	XB1021	1
		16	XB08559	2
		17	XA1029	1
		18	XBCX58F138	1
		19	XB07431	2
		20	XA1507	1
		21	XA07150R	1
		22	XBT69A	1
RK35503A	Jaw Replacement Kit c/w Yoke	1	XA0729282	2
		2	XB07398	2
		3	XA07296	1
		4	XB07628	1
		11	XA07295	1
		18	XBCX58F134	1
		24	XBH38A	2
RK06356	Holland Pin Pack	22	XBT69A	2
		27	XBC95	2
		28	XE06356	2
RK06356P	Pin & Bush Kit c/w Poly Bush	22	XBT69A	2
		27	XBC95	2
		28	XE06356	2
		29	XB16045P	2
RK1706	Yoke Shaft Replacement Kit	5	XBHNH34F	1
		6	XPW1316112	1
		7	XB1127	1
		8	XB02312	1
		9	XA1706	1
		10	XB1505	1
RK2016	Holland Pin Pack	37	XA2016	2
		38	XB21S3751750	2
RK16045P	Holland Bush Pack	29	XB16045P	2
RK3542R	Secondary Lock Replacement Kit	12	XB2149	1
		13	XB21S5002750	1
		14	XA3542R	1



FIFTH WHEELS PARTS

LowLube FW342

Section 1 - 8I

GO THE DISTANCE.

Part Number	Description	Item Number	Required Parts	Qty
RK0729282	Lock Pin Replacement Set	1	XA0729282	2
		2	XB07398	2
		35	XBH38A	2
RK10210	Foot Pocket Kit	26	XB10210	2
RKE1707L2	Release Handle	23	RKE1707L2	1
RK35504THK	Mini Rebuild Kit includes Foot Pins & Bushes	1	XA0729282	2
		2	XB07398	2
		3	XA07296	1
		4	XB07628	1
		11	XA07295THK	1
		18	XBCX58F134	1
		22	XBT69A	2
		24	XBH38A	2
		27	XBC95	2
		28	XE06356	1
29	XB16045P	2		



FIFTH WHEELS PARTS

FW70 - 72

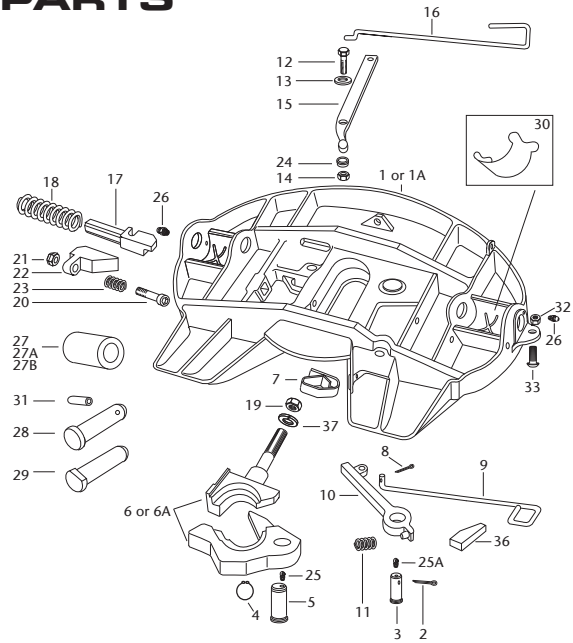
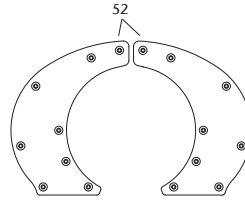
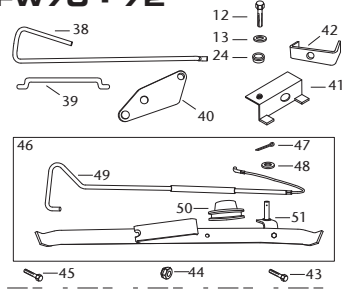

Section 1 - 8m

Item	Part No.	Description	Qty	Item	Part No.	Description	Qty
1	N/A	Fifth Wheel Plate for 2" Kingpin	1	26	XBH38	Grease Nipple	2
1A	N/A	Fifth Wheel Plate for 3 1/2" Kingpin	1	27*	XB16049AUSP	Bush 64mm O.D. Poly. Fabricated Foot	2
2	XBT60	Cotter Pin 1/4" x 2 1/2"	1	27A*	XB16049USAP	Bush 70mm O.D. Poly. Cast Foot	2
3	XA1016C	Lock Pin	1	27B*	XB0012P	Bush 51mm O.D. Poly. Foot suit Komp	2
4*	XB10A	Circlip	1	28*	XB2632	Foot Pin (prior to 1990)	2
5*	XAFW108D	Jaw Pin	1	29*	XE02759	Foot Pin (1990 onwards)	2
6*	XAFW104D	Lock Jaw set for 2" Kingpin	1	30	DOGBONE	Wear Pads - pair (optional)	1
6A*	XAFW10403	Lock Jaw set for 3 1/2" Kingpin	1	31	XB2155002750	Roll Pin 1/2" x 2 3/4"	2
7	XAFW128	Spring	1	32	XBT69A	Hex Lock Nut	2
8*	XB16	Cotter Pin 1/8" x 1"	1	33*	XBC95	Hex HD Bolt 1/2"-20 X 1 1/4"	2
9	XAFW78	Secondary Lock Release Handle	1	36+	XA05768	Adjusting Block	1
10	XAFW1372	Secondary Lock Arm	1	37*	XB10327	Lock Washer 1"	1
11	XB10282	Spring	1	38	XA071001	RH Release Handle	1
12	XB1021	Hex Head Cap Screw 1/2"-20 x 1 3/4"	1	39	XA071002	Linkage Bar	1
13	XBT49	Plain Washer	2	40	XA071003	Cam Plate	1
14	XBT69A	Hex Lock Nut	1	41	XA071004	Bracket Cam Plate	1
15	XA1005FH	Release Lever	1	42	XA071006	Retainer, Cable	1
16	XA1117H	Release Handle	1	43	XB14F114	Bolt 1/4" x 1 1/4"	2
17	XA1104	Plunger	1	44	XBHNH14F	Nut Nyloc 1/4"	2
18	XB1007	Compression Spring	1	45	FSP5323	Bolt 5/16" x 3/4"	1
19	XB04473	Jam Nut 1" - 14	1	46	XA071RS	RH Secondary Release Holland Assembly	1
20	XBCS58C312	Socket Head Cap Screw	1	47*	XBSK6999	Cotter Pin	1
21	XBHNS58C	Lock Nut 5/8" - 11	1	48*	XB2400123	Washer	1
22	XD31231	Adjusting Wedge	1	49	XB2100637	Handle & Cable Assy.	1
23	XB403	Compression Spring	1	50	XB2100629	Pulley	1
24	XB02949	Bushing	1	51	XB2100633	Frame Assy	1
25	XBH38A	Grease Nipple (90°)	1	52	2501550	Insert Set (Pair) c/w Fixings	1
25A	XB767C	Grease Nipple (90°)	1	*	Available in "RK" Kits only		
				+	Used only for pre1990 FW upgrade		



FIFTH WHEELS PARTS

Service Kits
FW70 - FW72

GO THE DISTANCE.

Section 1 - 8n

Part Number	Description	Item Number	Required Parts	Qty
RK65014	Rebuild Kit, XA-71-DA-15, 50mm FW70 Top Plate	2-25A		1
RK65015	Rebuild Kit, suit XA71OA15, 90mm FW70 Top Plate	2-25A		1
RK02759	Pin Pack	29 32 33	XE02759 XB769A XB08002	2 2 2
RK16049AP	Bush Pack, to suit Cast Foot	27	XB16049AUSP	2
RK16049UP	Bush Pack, to suit Fabricated Foot	27A	XB16049USAP	2
RK104O	3.5" Lock Set	4 5 6A 19 25 37	XB10A XAFW108D XAFW10403 XB04473 XBH38A XB10327	1 1 1 1 1 1
RK104D	2" Lock Set	4 5 6 19 25 37	XB10A XAFW108D XAFW104D XB04473 XBH38A XB10327	1 1 1 1 1 1
RK02759P	Pin & Bush Pack	27 29 32 33	XB16049AUSP XE02759 XBT69A XB08002	2 2 2 2
RK02759UP	Pin Bush Pack USA	27A 29 32 33	XB16049USAP XE02759 XBT69A XBC95	2 2 2 2



FIFTH WHEELS PARTS

Service Kits
FW70 - FW72

Part Number	Description	Item Number	Required Parts	Qty
RK65024	2" Lock Set Kit, FW70	6	XA05768	1
		10	XAFW1372	1
		36	XAFW10403	1
RK650241	3-1/2" Lock Set Kit, FW70	6A	XAFW10403	1
		10	XAFW1372	1
		36	XA05768	1
RK2632	Holland Pin Pack FW70 Series	28	XB2632	2
		31	XB21S5002750	2
RK2632UP	Pin & Bush Kit c/w Pin & 9USA Bush	27A	XB16049USAP	2
		31	XB21S5002750	2
		28	XB2632	2
RK2632P	Pin & Bush Kit c/w Old Pin & Bush	27	XB16049AUSP	2
		31	XB21S5002750	2
		28	XB2632	2
RK2632K	Pin & Bush Kit c/w Old Pin, Suit Older model FW70 (Komp only)	27B	XB0012P	2
		28	XB2632	2
		31	XB21S5002750	2
RK0012P	Holland Bush Pack (Poly) (Komp only)	27B	XB0012P	2
RK02759K	Pin & Bush Pack (Komp only)	27B	XB0012P	2
		29	XE02759	2
		32	XBT69A	2
		33	XB08002	2



FIFTH WHEELS PARTS

FW2080

GO THE DISTANCE.

Section 1 - 8p

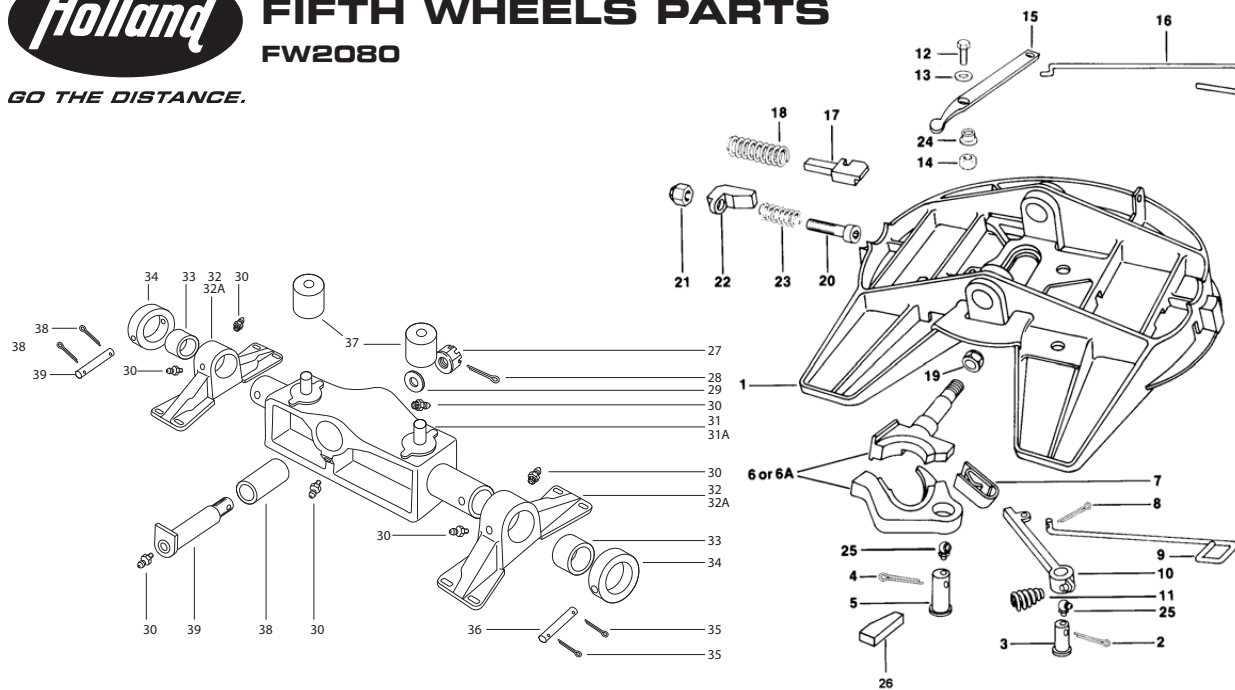

Item	Part Number	No. Req'd	Description	Item	Part Number	No. Req'd	Description
1	N/A	1	Fifth wheel top plate - 2" kingpin	18	XB1007	1	Compression spring (red)
1A	N/A	1	Fifth wheel top plate - 3 1/2" kingpin	19	XB04473	1	Jam nut 1"-14
2(a)	XB5	1	Cotter pin 1/4"x 2"	20	XBCS58C312	1	Socket head cap screw
3	XA1016C	1	Lock pin	21	XBHNH58C	1	Lock nut 5/8"-11
4(b)	XBT60	1	Cotter pin 1/4"x 2 1/2"	22	XD31231	1	Adjusting wedge
5*	XAFW108D	1	Lock pin	23	XB403	1	Compression spring
6*	XAFW104D	1	Lock set for 2" kingpin	24	XB02949	1	Bushing
6A*	XAFW10403	1	Lock set for 3 1/2" kingpin	25	XB767C	2	Grease nipple 90°
7	XAFW128	1	Spring	26+	XA05768	1	Adjusting block
8*	XB16	1	Cotter pin 1/8" x 1"	27	XB7801	1	Hex Slotted Nut 2 1/4"-4 1/2" socket
9	XAFW138	1	Release handle	28	XB7811	1	Cotter Pin 5/16" x 3 1/2"
10	XAFW1372	1	Secondary lock arm	29	XA782	1	Washer
11	XB10282	1	Spring	30	XBH38	7	Grease Zerk
12	XB1021	1	Hex head cap screw 1/2"-20 x 1 3/4"	31	XA05952	1	Rocker arm only
13	XBT49	1	Plain washer	31A	XA05952A	1	Rocker arm sub-assembly
14	XBT69A	1	Hex lock nut 1/2"-20	32	XA1595	2	Bracket only
15	XA1005FDS	1	Release lever	32A	XA1595A	2	Bracket sub-assembly
16	XA111713	1	Release handle	33	XA1596	2	Cast iron bushing
17	XA1104	1	Plunger	34	XA1597	2	Collar
				35	XB382	4	Cotter pin 3/16" x 1 1/4"
				36	XA15842	2	Pin
				37	XB70	2	Rubber cushion
				38	XA06110	1	Cast iron bushing
				39	XA15891	1	Bolt hub assembly

* Only available as part of a kit

** Used only for pre 1990 FW's

(a) Replacement part XBT60

(b) Replacement part XB10A



FIFTH WHEELS PARTS

Service Kits
FW2080

GO THE DISTANCE.

Part Number	Description	Item Number	Required Parts	Qty
RK65013	Rebuild Kit, XA-20801, XA-2081, 90mm (3 1/2")	3	XA1016C	1
		4	XBT60	1
		4(b)	XB10A	1
		5	XAFW108D	1
		6A	XAFW10403	1
		7	XAFW128	1
		8	XB16	1
		9	XAFW138	1
		10	XAFW1372	1
		11	XB10282	1
		12	XB1021	1
		13	XBT49	1
		14	XBT69A	1
		15	XA1005FDS	1
		16	XA111713	1
		17	XA1104	1
		18	XB1007	1
		19	XB04473	1
		20	XBCS58C312	1
		21	XBH58C	1
		22	XD31231	1
		23	XB403	1
		24	XB02949	1
		30	XBH38A	1



FIFTH WHEELS PARTS

Service Kits
FW2080

GO THE DISTANCE.

Part Number	Description	Item Number	Required Parts	Qty		
RK65012	Rebuild Kit, XA-2081, 50mm (2")	3	XA1016C	1		
		4	XBT60	1		
		4(b)	XB10A	1		
		5	XAFW108D	1		
		6	XAFW10403D	1		
		7	XAFW128	1		
		8	XB16	1		
		9	XAFW138	1		
		10	XAFW1372	1		
		11	XB10282	1		
		12	XB1021	1		
		13	XBT49	1		
		14	XBT69A	1		
		15	XA1005FDS	1		
		16	XA111713	1		
		17	XA1104	1		
		18	XB1007	1		
		19	XB04473	1		
		20	XBCS58C312	1		
		21	XBH58C	1		
		22	XD31231	1		
		23	XB403	1		
		24	XB02949	1		
		30	XBH38A	1		
		**RK650241	3.5" Lock Set Upgrade Kit	6	XAFW10403	1
				10	XAFW1372	1
				28	XA05768	1
		RK104O	3.5" Jaws USA	5	XAFW108D	1
				6A	XAFW10403	1
				19	XB04473	1
*	XB10A			1		
*	XBH38A			1		

* Item Not shown on exploded view diagram.

** Used only for pre 1990 FW upgrade.



FIFTH WHEELS PARTS

Kompensator

GO THE DISTANCE.

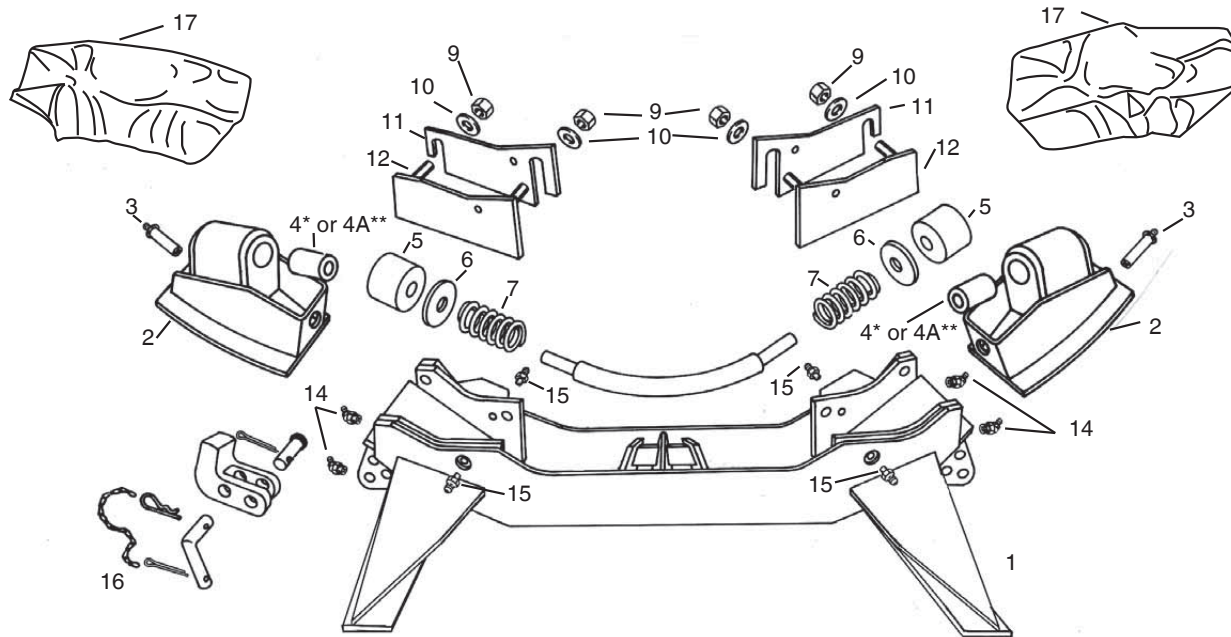

Item	Part Number	No. Req'd	Description	Item	Part Number	No. Req'd	Description
1			Kompensator assembly (N/A as a spare part)	8	XA39	1	Tie bar
2	XA0024	2	Shoes Subassembly - includes part no. (3)	9	XBC59	4	Hex nut 1/2-13
3	XBH38F	2	Grease fitting	10	XBT45	4	Lock washer
4*(a)	XB0011P	2	Cushion	11*	XA0014	2	Shim (as required)
4A*(b)	XB0012P	2	Cushion	12	XA01997	1	Bearing plate - right hand
5	XB0009	2	Cushion	13	XA01998	1	Bearing plate - left hand
6	XA12842	2	Washer	14	XBH38C	4	45 Grease fitting
7	XB01923	2	Spring	15	XBH38	4	Grease fitting
				16	RK01370	1	Lockout Kit
				17	XB0128	1	Dust Cover Set (Optional)

* Only available as part of a kit

(a) Bushing used in conjunctions with FW3500 & pro-hitch 351 fifth wheels.

(b) Bushings used in conjunction with FW70 fifth wheels.



FIFTH WHEELS PARTS

Service Kits
Kompensator

Part Number	Description	Item Number	Required Parts	Qty
RK0011P	Holland Bush Pack FW3540	4	XB0011P	2
RK0012P	Holland Bush Pack FW7040	4A	RK0012P	2
RK40IZ	Kompensator Rebuild Kit	4	XB0011	2
		5	XB0009	2
		7	XB01923	2
		11	XA0014	4
		12	XA01997	1
		13	XA01998	1
RK01370	Lockout Kit			1 set
RK06356K	Pin & Bush Kit c/w Bush to Suit pro-hitch 351 & XA342A LowLube	*	XE06356	2
		*	XBC95	2
		*	XBT69A	2
		4	XB0011P	2
RK2016KP	Pin & Bush Kit c/w Old Pin & Poly Bush to Suit FW3500	*	XA2016	2
		*	XB21S3751750	2
		4	XB0011P	2 2
RK02759K	Pin & Bush Kit to Suit FW70	*	XE02759	2
		*	XBC95	2
		*	XBT69A	2
		*	XB0012P	2
RK02632K	Pin & Bush Kit c/w Old Pin to Suit early FW70	*	XB2632	2
		*	XB21S5002750	2
		*	XB0012P	2
* Item not shown on exploded view diagram				



FIFTH WHEELS PARTS

Service Packs

Section 1 - 8u

GO THE DISTANCE.

Part No.	Description	Qty
RKS02104	Release Handle Kit B-Double	1pr
2501510	Insert set, LowLube yellow, suits XA342A 16 bolt	1pr
450411	Insert, LowLube suit XA3301A 14 bolt	1pr
2501508	Bolt set , imperial to suit Ballrace or fixed plate	1pk



FIFTH WHEELS PARTS

Custom Service Tools

GO THE DISTANCE.

Essential service and checking tools – specially designed for Holland products!

TF-TLN-5001

Fifth Wheel Lock Adjustment Tool
Designed specifically for the Holland FleetMaster top plate, but can be used with other Holland fifth wheels as well. Designed for checking fifth wheel locking action and lock adjustment during periodic adjustment or rebuilding.



FIFTH WHEEL LOCK
ADJUSTMENT TOOL
TLN5001



FIFTH WHEEL LOCK
ADJUSTMENT TOOL
TLN1500

TF-TLN-1500 (3 1/2")

Fifth Wheel Lock Adjustment Tool
These Holland kingpin lock testers are designed for checking fifth wheel locking action and lock adjustment.

TF-TLN-2500

Slider Spring Compressor
Designed exclusively for removing and installing springs, retainers and pins of the slide release mechanisms of Holland sliding fifth wheels. For best results, operate with a 5/8" socket and ratchet wrench.



SLIDER SPRING
COMPRESSOR
TF-TLN-2500



2" PLUG
TF0237

TF-0237

2" Plug
This 2" plug is used only for checking and adjusting the kingpin locks of the Type "B" fifth wheel during periodic maintenance. It also is designed to assist in lock installation and adjustment during rebuilding or lock replacement.

TF-04229-1

Fifth Wheel Rebuild Stand
The Holland fifth wheel rebuild stand allows top plate rotation for easy access to both bottom and top surfaces of the top plate for easy rebuilding. Easy nut and bolt assembly for convenience and compact storage.



FIFTH WHEEL
REBUILD STAND
TF042291



KINGPIN GAGE
TF0110

TF-0110

Kingpin Gage
The TF-0110 kingpin gage is a simple, multipurpose, economical gage for indicating an undersized condition and need of replacement of 2" and 3 1/2" SAE kingpins. This unique gage can also be used to check kingpin length and for checking straightness and flatness of the upper coupler or bolster plate.



FIFTH WHEELS PARTS
 Service Tools, Accessories & Equipment

GO THE DISTANCE.

Part Number	Description		
TF0237	Jaw Test Plug 50mm		
TF0110	Kingpin Gauge 50-90mm (Stainless Steel)		
TLN5001	Jaw Tester 50mm (suit FW3542)		
TLN1500	Jaw Tester 90mm		
TF042291	Fifth Wheel Rebuild Stand (suit all models)		
TBAR	Fifth Wheel Lock Tester (Sommonly)		
XB401ZLMK	Lubrication Manifold Kit (suit kompensator)		
XB351LMK	Lubrication Manifold Kit (suit pro-hitch 351)		
XB70LMK	Lubrication Manifold Kit (suit FW70)		
TLN2000	Complete Fifth Wheel Service Kit (includes the following)		
	TB30	1	Tool Box, Jumbo
	TBAR	1	Fifth Wheel Lock Tester (50mm only)
	TF0110	1	Kingpin Gauge 50-90mm (plastic)
	TF0237	1	Jaw Test Plug 50mm
	TF042291	1	Fifth Wheel Rebuild Stand (suit all models)
	TLN5001	1	Jaw Tester 50mm
	TLN1500	1	Jaw Tester 90mm
	CP217	1	FW3500 Rebuild Video
	CP217A	1	pro-hitch 351 Rebuild Video
			Holland Service Literature (2" Binder)



GO THE DISTANCE.

TYPE 65



KINGPINS

TYPE 63



SECTION 2

- Replaceable, Weld in

Accessories



GO THE DISTANCE.

KINGPINS

Replaceable
Weld in
Accessories



KINGPINS

Refer to individual item for D Rating

GO THE DISTANCE.

B. Series Replaceable Type 65

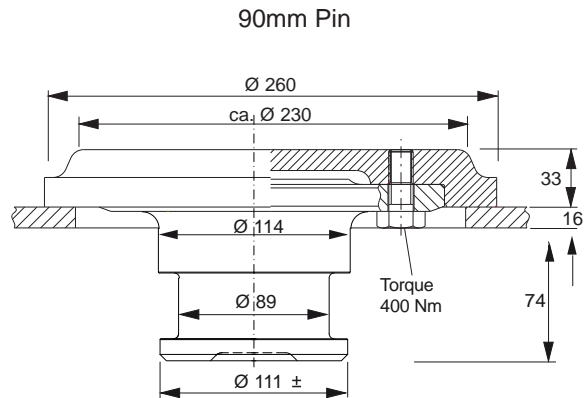
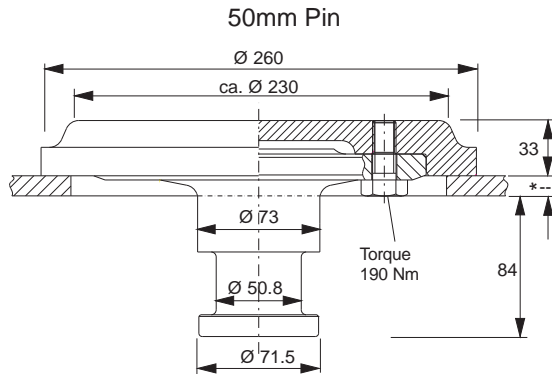

* Semi Trailer Skid Plate Thickness

Part Number	Description	D-Rating kN	CRN Number
KPB62818	50mm C/W Housing Suits 8mm Plate	210	16671
KPB62018	50mm C/W Housing Suits 10mm Plate	210	16671
KPB62218	50mm C/W Housing Suits 12mm Plate	210	16671
KPBS0001	50mm C/W Housing Suits 16mm Plate	210	16671
KPB62012	90mm C/W Housing Suits 10mm Plate	210	16670
KPB62014	90mm C/W Housing Suits 12mm Plate	210	16670
KPBS0003	90mm C/W Housing Suits 16mm Plate	210	16670
KPB51050	50mm King Pin Only (15.5mm Flange)	210	16671
KPB51042	90mm King Pin Only (15.5mm Flange)	210	16670
BP5103808	Housing Only Suits 8mm Plate		
BP5103810	Housing Only Suits 10mm Plate		
BP5103812	Housing Only Suits 12mm Plate		
BP5103816	Housing Only Suits 16mm Plate		
BP5103820	Housing Only Suits 20mm Plate		
RK330218	Bolt Set (8 x Bolts) M14 x 40mm		

B. Series Replaceable Type 63

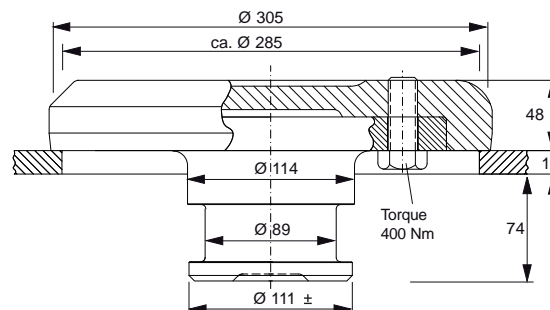

Part Number	Description	D-Rating kN	CRN Number
KPB62011	90mm Kingpin Suits 16mm Skid Plate	270kN	35478



KINGPINS

Refer to individual item for D Rating

GO THE DISTANCE.

Weld In

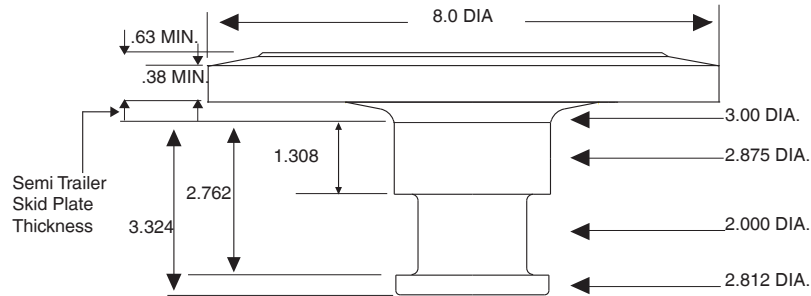

Part Number	Description	D-Rating kN	CRN Number
KPT809EF	50mm King Pin Suits 8mm Skid Plate	151 kN	16672
KPT809F	50mm King Pin Suits 10mm Skid Plate	151 kN	16672
KPT809BF	50mm King Pin Suits 12mm Skid Plate	151 kN	16672

Replaceable

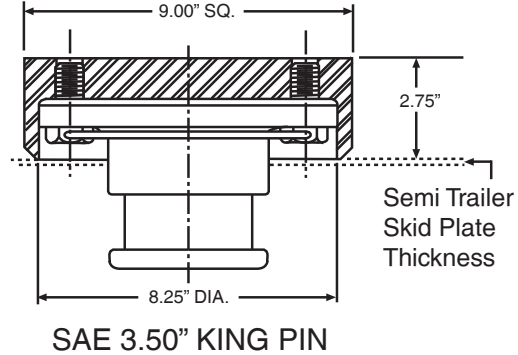
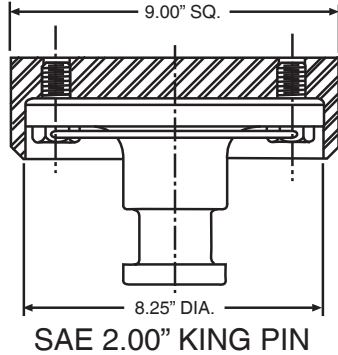

Part Number	Description	D-Rating kN	CRN Number
KP0882	50mm C/W Housing Suits 10mm Plate	200 kN	16673
KP0883	50mm C/W Housing Suits 12mm Plate	200 kN	16673
KP0884	90mm C/W Housing Suits 10mm Plate	200 kN	16674
KP0885	90mm C/W Housing Suits 12mm Plate	200 kN	16674
XA0676	50mm King Pin Only	200 kN	16673
XA0677	90mm King Pin Only	200 kN	16674
XA0767	Housing Only Suits 10mm Plate		
XA0768	Housing Only Suits 12mm Plate		
RK08868	Bolt Set (8 x Bolts) 3/4"		



GO THE DISTANCE.

PH16B



COUPLING

DB060FQ1



SECTION 3

- Pintle Hooks 1
- Drawbars 2



GO THE DISTANCE.

PINTLE HOOKS

- PH16B
- PHT60AOL8
- PH300 / PH3001
- PH775E



COUPLINGS

Rigid Mount Duplex Pintle Hook 50mm Diameter Ball

Forged alloy steel and heat treated throughout for toughness, strength, and durable operation. A special rigid mount duplex pintle hook that combines a pintle hook and ball hitch. Designed for customers who need the strength and capacity to pull trailers equipped with drawbars, as well as the flexibility to pull trailers with ball hitches. Tested in accordance with SAE J847 (Type II) and ADR 62/O1. Meets J684 Class 4 standard for a 2" (50.4 mm) ball.

NOTE: For off-road applications, reduce the stated capacities by 25% and use with a swivel-mount drawbar.

Lighter weight yet stronger than the competitor's offering.

The secondary lock is a "D" ring for added safety.

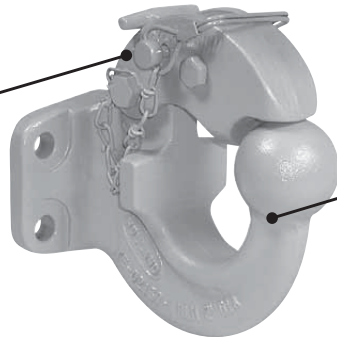

50mm ball is permanently attached. It cannot be stolen or misplaced.

Our unique design is stronger and more durable than a removable ball design. The special shape eliminates premature wear typically caused by the drawbar pulling against the ball. Provides better oscillation or articulation in off-road conditions than a removable ball hitch.

Part Number	Length	Weight	Maximum Vertical Load	*Maximum Gross Trailer Weight	D-Rating kN	CRN Number
PH16B	165.1 mm	4.5 kg	1,724 kg	8,618 kg	20 kN	25767

IMPORTANT: *Maximum Gross Trailer Weight for the 50 mm Ball is 4,536 kg (10,000 lbs).

Drawbar Eye Dimensions: 60.4 mm to 76.2 mm I.D. with 31.7 mm to 41.4 mm diameter section.

Rigid Mount Pintle Hook

Forged alloy steel and heat treated throughout for toughness, strength, and durable operation. A versatile rigid mount pintle hook designed for over-the road and off-road towing within stated capacities. Tested in accordance with SAE J847 (Type II) and ADR 62/O1.

NOTE: For off-road applications, reduce the stated capacities by 25% and use with a swivel-mount drawbar.

A chain and cotter pin are the secondary lock.

Surfaces are machined to tight tolerances to ensure durability.

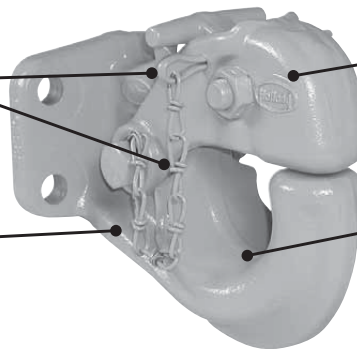

The latch is forged alloy steel and heat treated for strength and long life.

The special pintle body shape is designed for maximum articulation or oscillation and reduced wear.

Part Number	Length	Weight	Maximum Vertical Load	Maximum Gross Trailer Weight	D-Rating kN	CRN Number
PHT60AOL8	159.7 mm	5 kg	2,722 kg	13,608 kg	35	26465

IMPORTANT: Drawbar Eye Dimensions: 50.8 mm to 76.2 mm I.D. with 31.7 mm to 41.4 mm diameter section.

NOTE: Specifications regarding measurements and weights are nominal only. We reserve the right to make changes as necessary.



COUPLINGS

Rigid Mount Pintle Hook With Air Cushioned Snubber

A rigid mount pintle hook designed for trailers, semitrailers, and double operations. Used for off- and over-the-road applications, with an air cushioned snubber; designed to minimize the space between the pintle hook and the drawbar and helps provide some shock absorption. This pintle hook is recommended for severe duty applications. Tested in accordance with SAE J847 (Type II) and ADR 62/O1.

NOTE: For off-road applications, reduce the stated capacities by 25% and use with a swivel-mount drawbar.

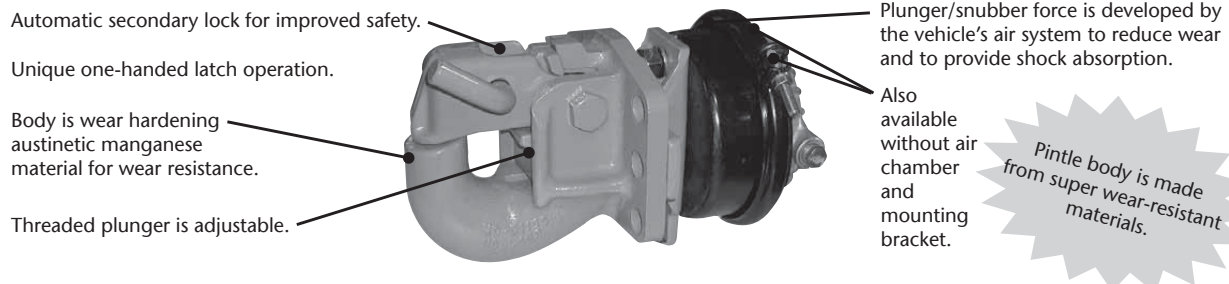

Part Number	Length	Weight	Maximum Vertical Load	Maximum Gross Trailer Weight	D-Rating kN	CRN Number
PH300	*184.1 mm	19 kg	8,165 kg	32,659 kg	165	24295
PH3001	184.1 mm	13 kg	8,165 kg	32,659 kg	165	24295

IMPORTANT: *Length Dimension is external to mounting structure. The added measurement is 146.3 mm. Drawbar Eye Dimensions: 60.4 mm to 76.2 mm I.D. with 31.7 mm to 41.4 mm diameter section. The complete assembly includes a pintle body, plunger, air chamber, and mounting brackets. For pintle hooks without an air chamber, bracket, or plunger, order PH3001. The PH300 can be operated with or without the air chamber.

Swivel Mount Pintle Hook

Forged alloy steel and heat treated throughout for toughness, strength, and durable operation. Extreme duty construction, logging, milk hauling primarily off-road applications provides torsional relief where a significant amount of articulation is required in a swivel-type mount pintle hook.

NOTE: For off-road applications, reduce the stated capacities by 25% and use with a non-swivel mount drawbar.



Part Number	Length	Weight	Maximum Vertical Load	Maximum Gross Trailer Weight	D-Rating kN	CRN Number
PH775E	*214.4 mm	25 kg	9,072 kg	45,360 kg	N/A	N/A

IMPORTANT: *Length Dimension is external to mounting structure. The added measurement is 167.7 mm. Drawbar Eye Dimensions: 76.2 mm I.D. with a 41.4 mm diameter section.

NOTE: Specifications regarding measurements and weights are nominal only. We reserve the right to make changes as necessary.



GO THE DISTANCE.

DRAWBARS

- DB1385
- DB040DQ1
- DB045BW1
- DB61030S



COUPLINGS

Rigid Mount Bolt-On Drawbar (4 Bolt Mounting Base/Plate Mount)

Forged alloy steel and heat treated throughout for toughness, strength, and durable operation. Used on trailers, semitrailers (including doubles), and equipment designed for on- and off-road towing applications within the stated capacities. Tested in accordance with SAE J847 (Type II).

NOTE 1: Not designed to be welded to a trailer tongue.

NOTE 2: For off-road applications, reduce the stated capacities by 25% and use with a swivel-mount coupling device.

The bolt pattern is the same as the previous DB1385 model but uses 20mm bolts.

Weighs less than the competition.

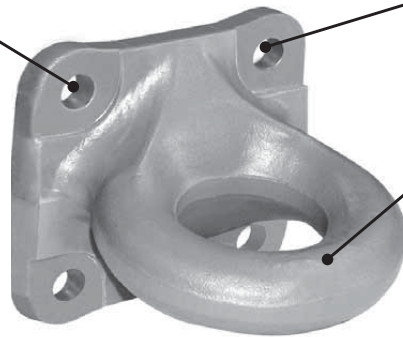

The bolt head area is strengthened for greater strength and durability than similar products.

The drawbar eye is 76.2mm I.D. with a 41.4mm diameter cross section. It is induction hardened in the pintle hook contact area for increased strength and wear resistance.

Additionally tested in accordance with ADR 62/01.

Part Number	Length	Weight	Maximum Vertical Load	Maximum Gross Trailer Weight	D-Rating kN	CRN Number
DB1385	173.4 mm	8.6 kg	6,804 kg	27,216 kg	165 kN	24296

IMPORTANT: When used with hinged tongue trailers, where the maximum vertical load cannot exceed 227kg (500 lbs,) the maximum gross trailer weight is 40,824 kg (90,000 lbs.).

Rigid Mount Bolt-On Drawbar (4 Bolt Mounting Base/Plate Mount) Replaces DB125015

The bolt pattern is the same as Holland model DB-1250-15.

Ultra-light weight with superior strength!

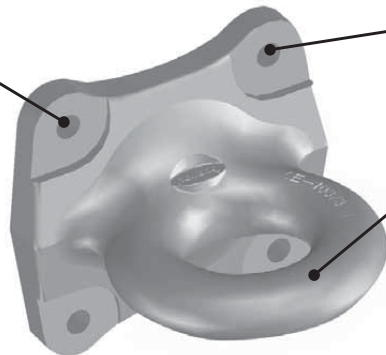

The bolt head area is strengthened for more durability than similar products.

For maximum durability and minimum wear, the drawbar eye has a 63.5mm I.D. with a 31.75mm x 38.1mm diameter section to match a pintle horn or coupler jaw.

Part Number	Length	Weight	Maximum Vertical Load	Maximum Gross Trailer Weight	D-Rating kN	CRN Number
DB040DQ1	155.7 mm	6.3 kg	3,629 kg	18,144 kg	N/A	N/A

IMPORTANT: When used with hinged tongue trailers, where the maximum vertical load cannot exceed 227kg (500 lbs,) the maximum gross trailer weight is 27,216 kg (60,000 lbs.).

NOTE: Specifications regarding measurements and weights are nominal only. We reserve the right to make changes as necessary.



GO THE DISTANCE.

COUPLINGS

Swivel Mount Weld-On Drawbar

Section: 3 - 2b

Forged alloy steel and heat treated throughout for toughness, strength, and durable operation. Used on straight tongue trailers, semitrailers (including doubles), and equipment designed for on- and off-road towing applications within the stated capacities.

NOTE 1: This drawbar must be used only in conjunction with a rigid mount coupling device.

NOTE 2: For off-road applications, reduce the stated capacities by 25%.

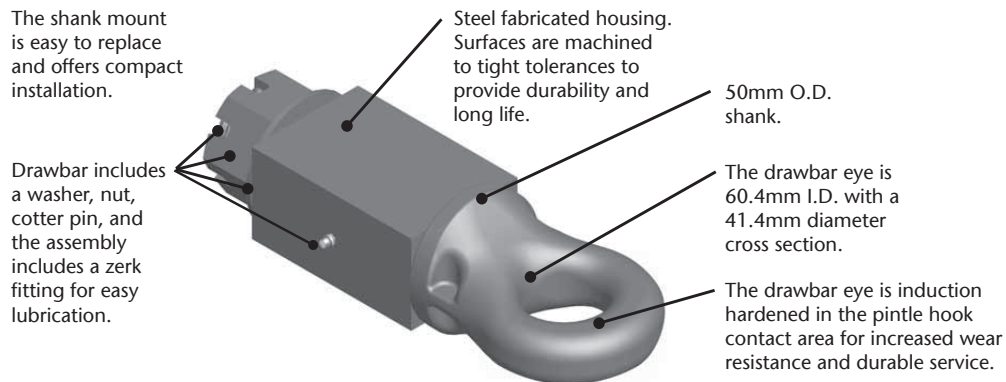

Part Number	Length	Weight	Maximum Vertical Load	Maximum Gross Trailer Weight	D-Rating kN	CRN Number
DB045BW1	381 mm	17.3 kg	4,082 kg	20,412 kg	N/A	N/A

IMPORTANT: When used with hinged tongue trailers, where the maximum vertical load cannot exceed 227kg (500 lbs,) the maximum gross trailer weight is 38,556 kg (85,000 lbs.).

Swivel Mount Weld-On Drawbar

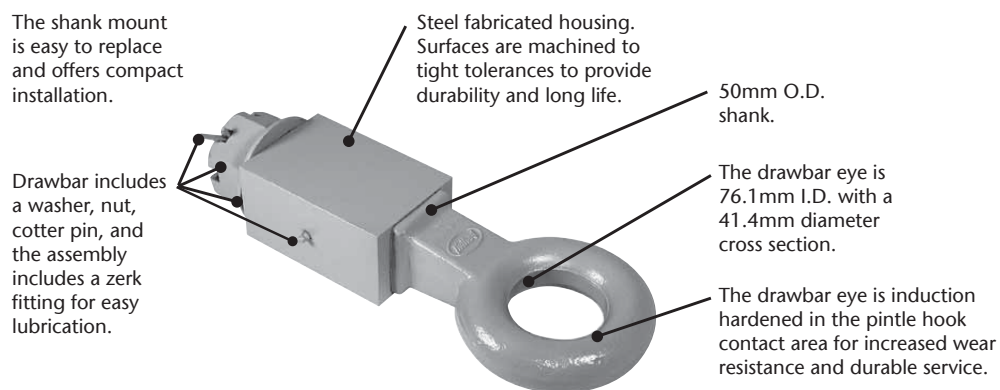

Part Number	Length	Weight	Maximum Vertical Load	Maximum Gross Trailer Weight	D-Rating kN	CRN Number
DB61030S	434.9 mm	16.3 kg	4,082 kg	20,412 kg	N/A	N/A

IMPORTANT: When used with hinged tongue trailers, where the maximum vertical load cannot exceed 227kg (500 lbs,) the maximum gross trailer weight is 38,556 kg (85,000 lbs.).

NOTE: Specifications regarding measurements and weights are nominal only. We reserve the right to make changes as necessary.



GO THE DISTANCE.

LG5000



LANDING GEAR

MARKV



SECTION 4

- MARK V	1
- LG5000	2
- Light Commercial	3



GO THE DISTANCE.

MARK V

Mark V
Landing Gear

Geared Leg
Slave Leg

The landing gear that
set the standard for
strength, durability,
and ease of lift.



LANDING GEAR

Mark V Lgs Series

GO THE DISTANCE.

Ordering Information

STEP 1

MODEL NUMBER

STEP 2

SELECT TRAVEL AND MOUNTING

STEP 3

SELECT AXLE AND FOOTWARE

Description	Model	Travel Code	Mounting Code	Axle Type Code	Footware Code	Dimensions
Standard set	LGS	343	1	Universal	Z	No Axle 0 Self Leveller 01 305 diameter
Heavy Duty	LGH	419	3			
Slave leg	LGS9	447	4			
Geared leg	LGS8	475	5			

Axle Type Code	Footware Code	Dimensions
Standard pipe 1	No Footware 10	
Solid heavy duty 3	Standard skid 15	96x254x282
	Heavy duty skid 12	102x254x406
	Wheel 03	228 Diameter
	Rocker 20	125x240x125R
	Compensating 09	130X230X330

ORDERING EXAMPLE:

STEP 1
LGS

STEP 2
5Z

STEP 3
115

Model Number

Travel Code + Mounting Code

Axle Type + Footware Code

All dimensions shown are in mm

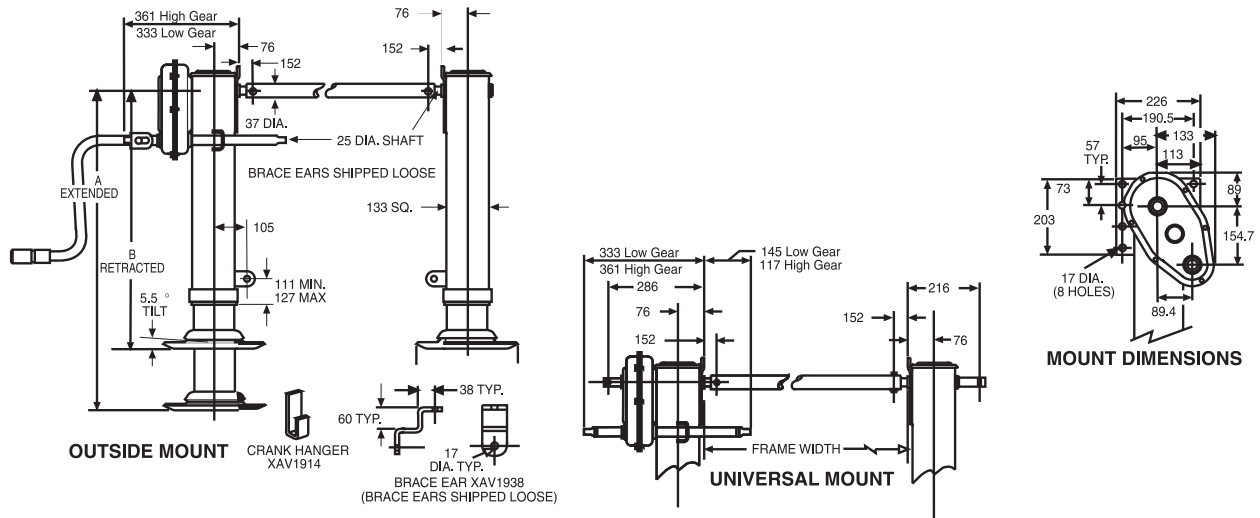

Landing Gear Dimensions

Travel	Self Leveller			Standard Skid			Heavy Duty Skid			Wheel			Rocker			Compensating		
	A	B	kg	A	B	kg	A	B	kg	A	B	kg	A	B	kg	A	B	kg
343	1062	719	84	1054	711	88				1072	729	90	1083	740	110	1088	745	112
419	1214	795	91	1207	787	95				1224	805	97	1235	816	117	1240	821	118
447	1270	823	92				1270	848	129									
475	1328	853	93	1321	846	97				1338	864	99	1350	875	119	1354	879	121

All dimensions shown are in mm-Weights are approximate and do not include cross shaft winding handle and fixings (Add 6kg)

Landing gear set includes: cross shaft, crank handle, crank hanger, brace ears (2 required) and crank hardware.

Note: Specifications regarding heights and weights are nominal only. We reserve the right to make changes as necessary.



GO THE DISTANCE.

LANDING GEAR

Mark V Lgs Series

Section: 4 - 1b

Sets

Part Number	Weight kg	Description
LGS1Z001	89	L/Gear set, Self Levelling Foot, Short Series
LGS1Z010	80	L/Gear set, w/o Foot Group, Suits Wheel, Skid or Rocker
LGS1Z103	97	L/Gear set, Wheeled, Short Series
LGS1Z109	106	L/Gear set, Compensating Foot, Short Series
LGS1Z115	94	L/Gear set, Skid Foot, Short Series
LGS1Z120	104	L/Gear set, Rocker Foot, Short Series
LGS3Z001	95	L/Gear set, Self Levelling Foot, Medium Series
LGS3Z010	85	L/Gear set, w/o Foot Group, Suits Wheel, Skid or Rocker
LGS3Z103	102	L/Gear set, Wheeled, Medium Series
LGS3Z109	111	L/Gear set, Compensating Foot, Medium Series
LGS3Z115	99	L/Gear set, Skid Foot, Medium Series
LGS3Z120	109	L/Gear set, Rocker Foot, Medium Series
LGS4Z001	97	L/Gear set - Self Levelling Foot
LGS5Z001	99	L/Gear set - Self Levelling Foot - Long Series
LGS5Z010	88	L/Gear set - w/o Foot Group (Suits Wheel, Skid or Rocker)
LGS5Z103	105	L/Gear set - Wheeled
LGS5Z109	114	L/Gear set - Compensating Foot
LGS5Z115	101	L/Gear set - Skid Foot
LGS5Z120	112	L/Gear set - Rocker Foot for Air Suspension

Dual Geared Leg Sets

LGS4X001	125	L/Gear set - Two Geared Legs - Self Levelling Foot
LGS5X010	100	L/Gear set - Two Geared Legs - w/o Foot Group (suits Wheel, Skid or Rocker)
LGS5X103	117	L/Gear set - Two Geared Legs - Wheeled
LGS5X115	113	L/Gear set - Two Geared Legs - Skid Foot
LGS5X120	124	L/Gear set - Two Geared Legs - Rocker Foot

Heavy Duty Series

LGH4A312	148	L/Gear set - Heavy Duty - Skid Foot
LGH4X312	164	L/Gear set - Heavy Duty - Two Geared Legs-Skid Foot

All sets supplied with a Crank Handle, Cross Shaft & Hardware Kit

Note: Specifications regarding heights and weights are nominal only. We reserve the right to make changes as necessary.



GO THE DISTANCE.

LANDING GEAR

Mark V Lgs Series

Single Legs Only

Geared Legs Only

Part Number	Weight kg	Description
LGS84Z001	52	Geared Leg - Self Levelling Foot
LGS85Z010	48	Geared Leg with Handle w/o Foot Group. Suit Wheel, Skid or Rocker
LGS85Z103	56	Geared Leg - Wheeled
LGS85Z109	60	Geared Leg - Compensating Foot
LGS85Z115	55	Geared Leg - Skid Foot
LGS85Z120	59	Geared Leg - Rocker Foot
LGH84Z312	74	Geared Leg - Heavy Duty Skid Foot

Slave Legs Only

LGS94Z001	41	Slave Leg - Self Levelling Foot
LGS95Z010	36	Slave Leg w/o Foot Group suit Wheel Skid or Rocker
LGS95Z103	45	Slave Leg - Wheeled
LGS95Z109	48	Slave Leg - Compensating Foot
LGS95Z115	43	Slave Leg - Skid Foot
LGS95Z120	47	Slave Leg - Rocker Foot
LGH94Z312	62	Slave Leg - Heavy Duty Skid Foot

All Single Geared Legs supplied with Ear Braces, Crank Handle & Hanger.

Note: Specifications regarding heights and weights are nominal only. We reserve the right to make changes as necessary.



GO THE DISTANCE.

LG5000

LG5000
Landing Gear

A premium,
heavy-duty leader
the proven standard
for the long haul.



LANDING GEAR

LG5000

GO THE DISTANCE.

Ordering Information

STEP 1

MODEL NUMBER AND MOUNTING

STEP 2

SELECT TRAVEL

STEP 3

SELECT FOOTWARE

Description	Model
Standard set	LG5

Mounting	Code
Universal	0

Travel	Code
342.9 (13.5")	13
393.7 (15.5")	15
431.7 (17")	17
482.5 (19")	19

Footware	Code	Dimensions
Skid	S	254x254x114.3

ORDERING EXAMPLE:

STEP 1

LG50

STEP 2

13

STEP 3

S

Model Number + Mounting Code

Travel Code

Footware Code

All dimensions shown are in mm

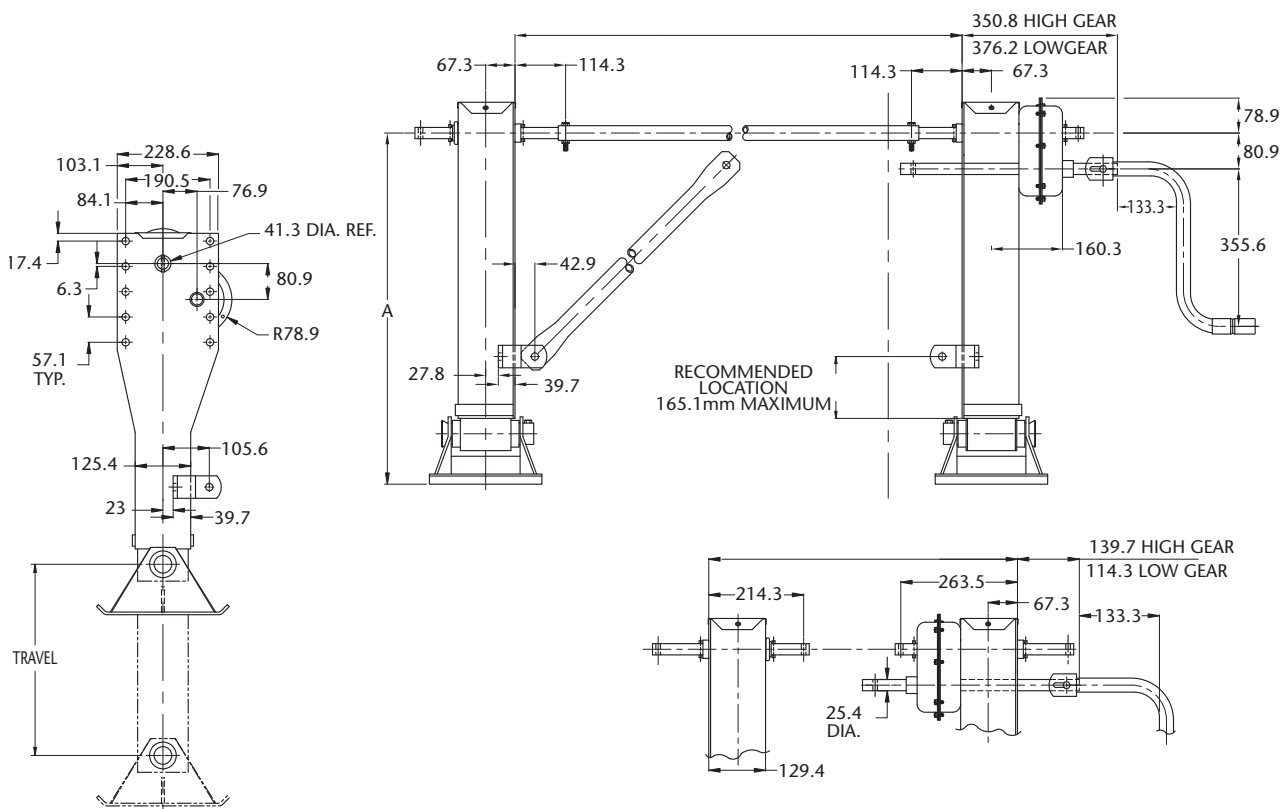

Landing Gear Dimensions

Description	A
(254x254x114.3 Sandshoe)	
342.9 (13.5") Travel	28.688"
393.7 (15.5") Travel	29.688"
431.7 (17") Travel	31.188"
482.5 (19") Travel	33.688"

Note: Specifications regarding heights and weights are nominal only. We reserve the right to make changes as necessary.



GO THE DISTANCE.

LIGHT COMMERCIAL

Light Commercial
Landing Gear

LG700
HC3J



LANDING GEAR

Light Commercial

GO THE DISTANCE.

Dual Pin Drop Leg

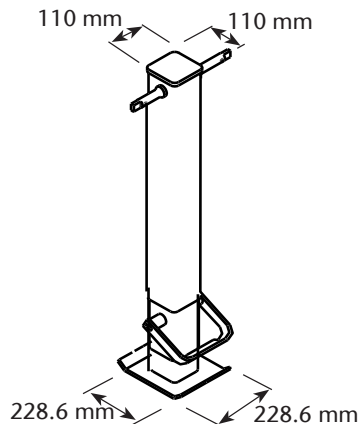

45.5kg input torque 5,682 kg
 Crank Travel 305 mm
 Drop Leg Travel 355 mm
 Crank Turns per 25mm Travel 8.75

Part Number	Static Capacity	Lift Capacity	Extended Length	Retracted Length	Weight
LG700	9,090 kg	134 Nm	1,279.5 mm	619 mm	30 kg

Dolly Jack with Wheel

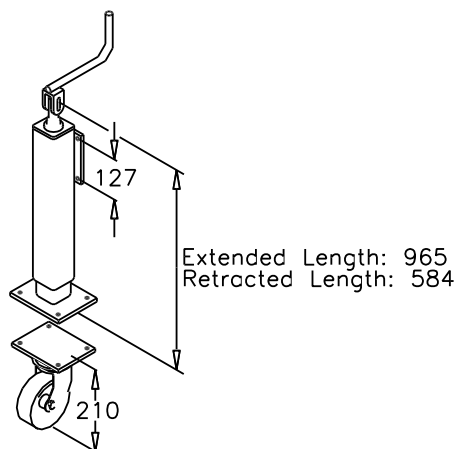

Travel 381 mm
 Crank Turns per 25mm Travel 4

Part Number	Static Capacity	Lift Capacity	*Extended Length	*Retracted Length	Weight
HC3J	454 kg	227 kg	949 mm	568 mm	18 kg

* Does not include wheel height of 210mm

Note: Specifications regarding heights and weights are nominal only. We reserve the right to make changes as necessary.



GO THE DISTANCE.

PARTS

Parts
Landing Gear



GO THE DISTANCE.

LANDING GEAR

Spare Parts
Model Identification

Model LGS

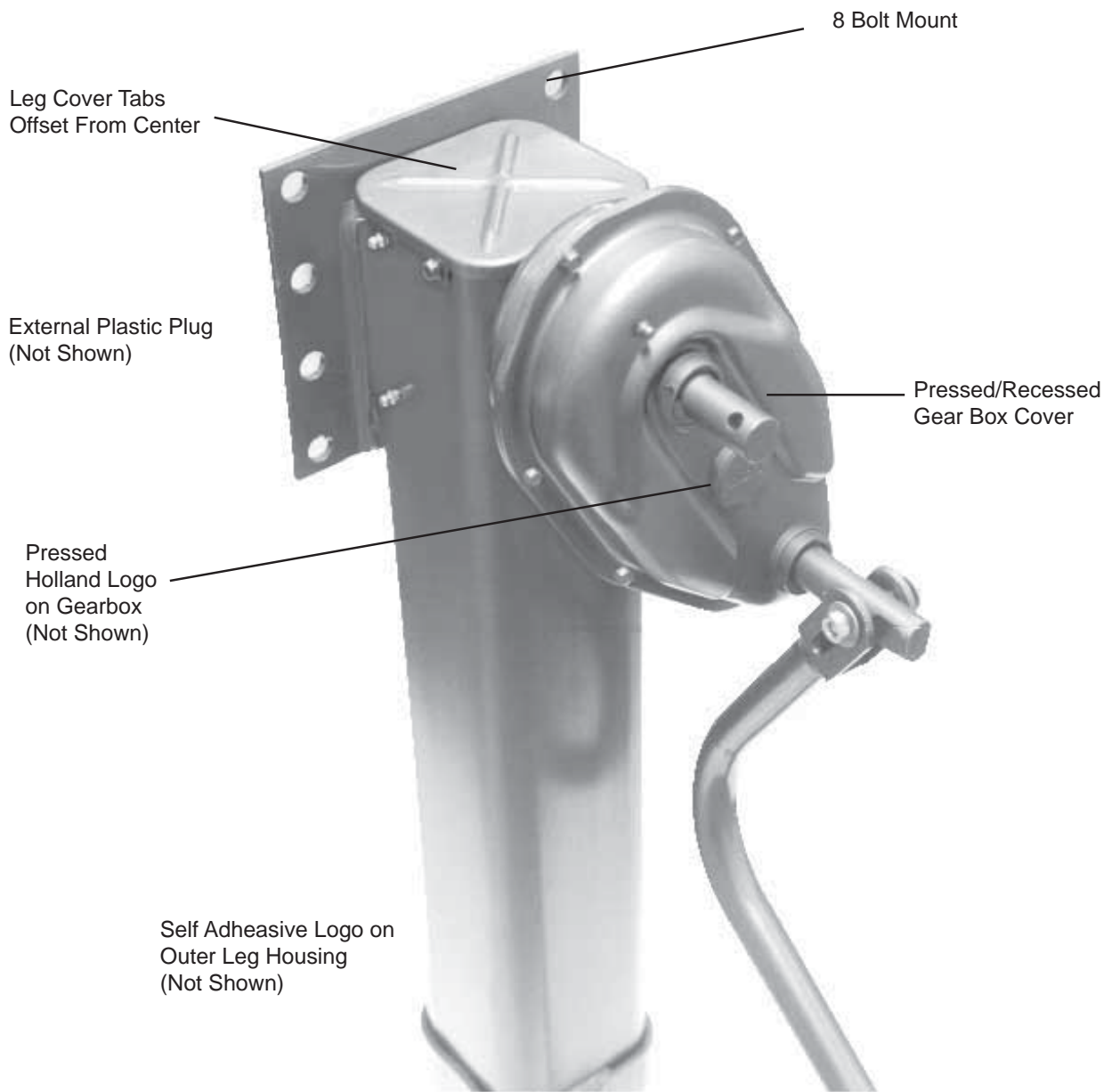

Gears
Highspeed - 2.5 turns per inch
Low speed - 33.3 turns per inch

LANDING GEAR

Spare Parts
Mark V - (Figure 1)

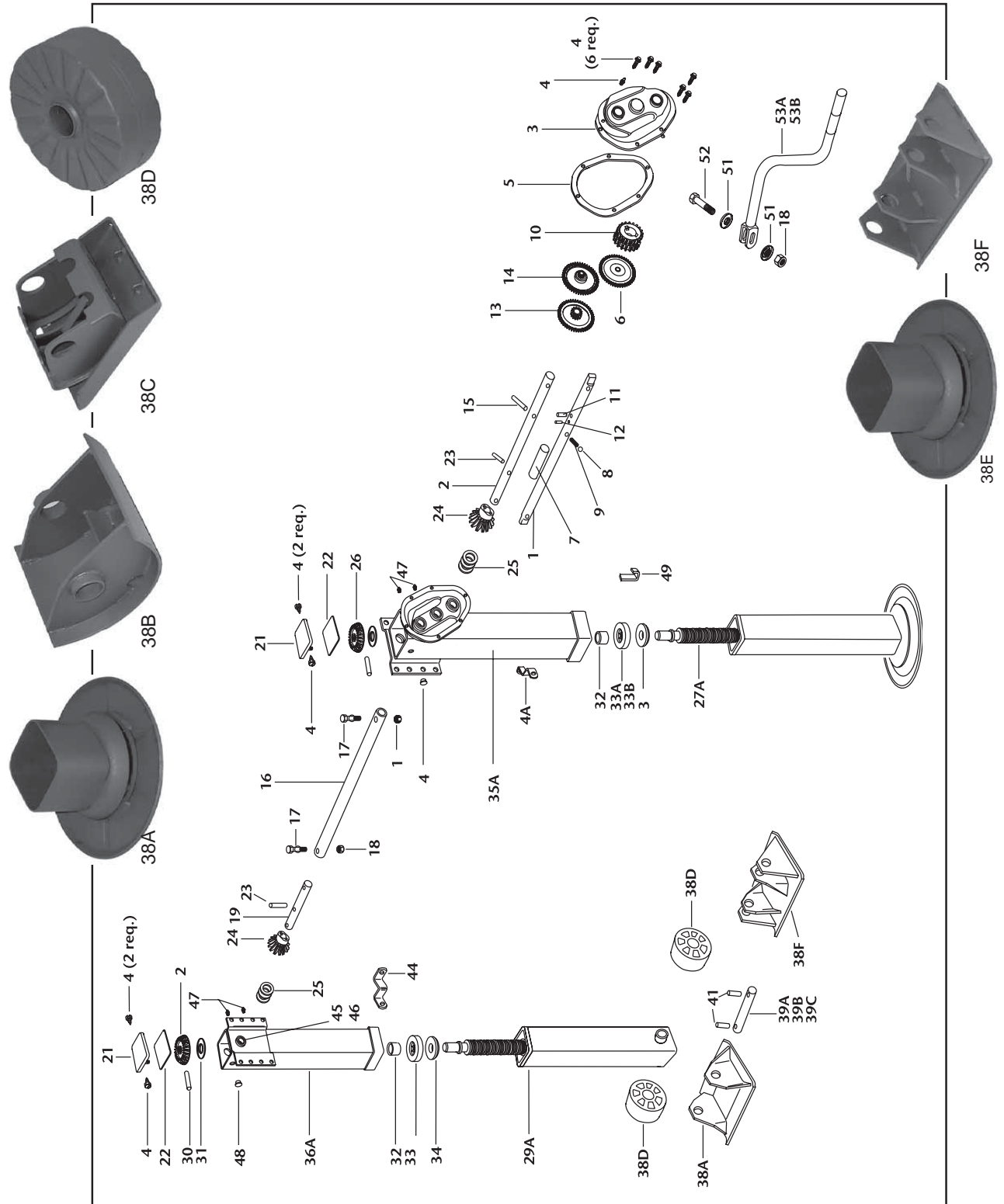



LANDING GEAR

Spare Parts
Mark V

Item	Part Number	Description	Item	Part Number	Description
1	XAV06625A	Crankshaft	34	XAV06629	Collar
2	XAV06624A	Drive gear shaft	35A	Not available seperately	
3	XAV06618	Gearbox cover assembly	36A	Not available seperately	
4	XB06372	Thread rolling screw	38A	XAV796WS	Weight saver skid foot, 3.8" x 10" x 11.5"
5	XBV06621	Gearbox gasket	38B	XAV818R	Rocker foot
6	XAV06602	Idler ear	38C	RKE1091	Compensating foot kit
7	XAV07085	Idler gear shaft	38D	XBV747	Wheel
8	XBPP002301	Ball	38E	N/A	Self leveling foot
9	XBPP002002	Spring	38F	XAV796T	Heavy duty skid foot
10	XAV066041	Shifter gear	39A	XAV19011	Axle, suits skid & compensating foot
11	XACRPV06633	Pin, 25" x 1.44"	39B	XAV19014	Axle rocker foot
12	XB21S2181250	Spring pin, 22" x 1.25"	39C	XAV19012	Axle wheel
13	XAV06606	Spur gear	39D	XAV19013	Axle, suit HD skid foot
14	XAV06603	Step gear	41	XB21S3753000	Rollpin .38" x 3"
15	XACRPV06634	Pin, 38" x 1.5"	44	XAV1938	Ear brace
16	XAV19101000	Cross shaft, 1 mtr long	45	XBLG0559	Bearing
17	XBV4441	HHCS, 3/8" - 16 x 1.75"	46	XBLG1570	Retainer
18	XB338	Locknut, 3/8"-16	47	XB767	Lube fitting
19	XAV06623A	Bevel pinion gear	48	XB01789	Plastic plug
21	XAV06611	Upper leg cover	49	XBLG0085	Crank hanger
22	XBV07054	Gasket	51	XB1108	3/8" SAE washer
23	XB02065	Groove pin	52	XBH332	HHCS, 1/4"-28 x 3"
24	XAV06600	Bevel pinion gear	53A	XAV902A	Crank, short
25	XB01977	Shim	53B	XAV9010A	Crank, long
26	XAV06601	Bevel gear	*54	XAV85	Lever
27A	XAV066280101 thru 515-1	Inner leg & screw assy.	*55	XBV932	Spring
29A	XAV066280000 thru 505-0	Inner leg & screw assy.	*56	XBV06622	Bushing retainer -open
30	XACRPV06635	Pin, 38" x 2"	*57	XBV07082	Bushing, retainer -closed end
31	XBV06632	Washer	*58	XBLG065801	Bushing, shifter
32	XBV06630	Bushing	*59	XBLG065801	Spring, compensating foot (used in 38C)
33	XBV647	Thrust bearing			

* Items not shown



GO THE DISTANCE.

LANDING GEAR

Spare Parts
Model Identification

Model LG75

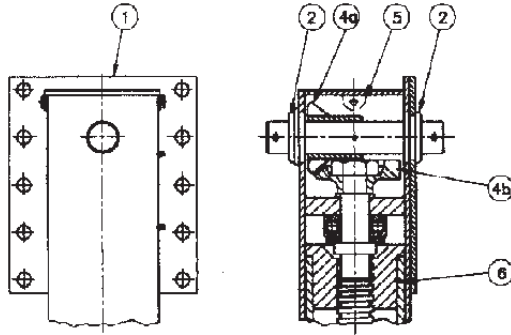

MANUFACTURED BEFORE 01/02/90

- | | | |
|---|---------------------------------|--------------------------------------|
| 1 | Long mounting plate | (10 holes) |
| 2 | Brass bushings | XBV851 |
| 3 | Turns per inch | (high speed - 4)
(low speed - 25) |
| 4 | Bevel gears | (a) XAV1961
(b) XAV1962 |
| 5 | Leg cover tabs centered | |
| 6 | Inner leg and screw subassembly | |

Model EX75

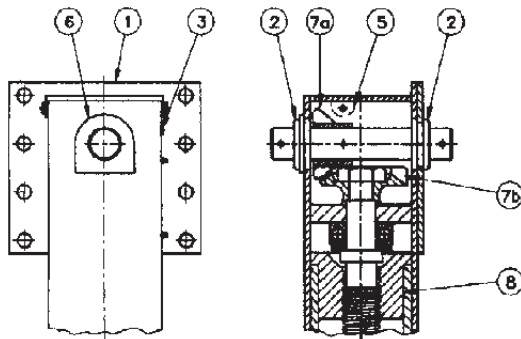

MANUFACTURED FROM 01/02/90 TO 30/06/92

- | | | |
|---|---------------------------------------|--|
| 1 | Short mounting plate | (8 holes) |
| 2 | Plastic bushings | XB0307 |
| 3 | Plastic plug | XB01789 |
| 4 | Turns per inch | (high speed - 4.6)
(low speed - 28.8) |
| 5 | Leg cover tabs offset from center | |
| 6 | "D" shaped piece for bushing retainer | |
| 7 | Bevel gears | (a) XAV05272
(b) XAV042051 |
| 8 | Inner Leg and screw subassembly | |

Model EXA75

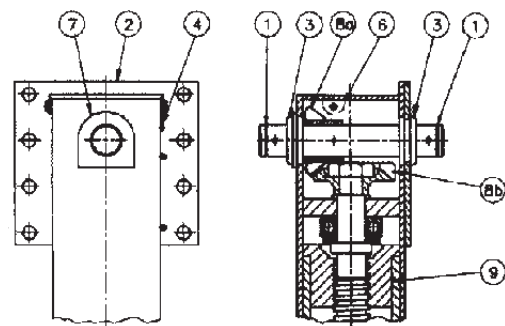

MANUFACTURED SINCE 1/07/92 TO 31/05/94

- | | | |
|---|---------------------------------------|--------------------------------------|
| 1 | Grooves on shaft | |
| 2 | Short mounting plate | (8 holes) |
| 3 | Plastic bushings | XB0307 |
| 4 | Plastic plug | XB01789 |
| 5 | Turns per inch | (high speed - 4)
(low speed - 25) |
| 6 | Leg cover tabs offset from center | |
| 7 | "D" shaped piece for bushing retainer | |
| 8 | Bevel gears | (a) XA03878
(b) XAV1962 |
| 9 | Inner leg and screw subassembly | |



GO THE DISTANCE.

LANDING GEAR

Spare Parts

Chart # 1
Drive Shaft for Single Speed Leg

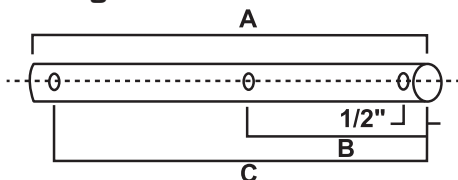

Model Number	When Used	Part Number	A	B	C
LG75	Before 1/2/90	① XAV1939	12"	7"	11 1/2"
EX75	Between 1/2/90 to 30/6/92	XAV05123A	15 1/2" (393.7)	5 5/16" (135)	14" (355.6)
EXA75	Between 1/7/92 to 30/4/94	② XAX05123A	16" (406.4)	5 1/4" (133.4)	15 1/4" (387.4)
LGS	After 1/5/94	XAV06623A	15 1/2" (393.7)	5 3/16" (131.8)	15" (381)

Chart # 2
Drive Shaft for Two Speed Leg

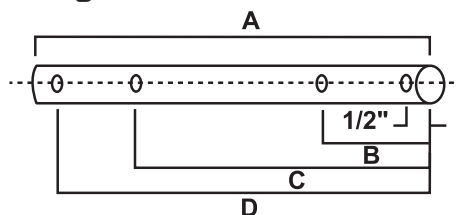

Model Number	When Used	Part Number	A	B	C	D
LG75	Before 1/2/90	③ XA03823A	18 1/4" (463.6)	3 1/2" (89)	8 3/4" (222.2)	17 3/4" (451)
EX75	Between 1/2/90 to 30/6/92	XAV05122A	18 1/4" (463.6)	3 1/2" (89)	9 7/16" (239.7)	17 3/4" (451)
EXA75	Between 1/7/92 to 30/4/94	④ XAX05122A	18 3/4" (476)	3 3/4" (95)	10" (254)	18" (457)
LGS	After 1/5/94	XAV06624A	18 1/4" (463.6)	4 7/32" (107)	9 25/32" (248.5)	17 3/4" (451)

Chart # 3
Crank Shaft for Two Speed Leg

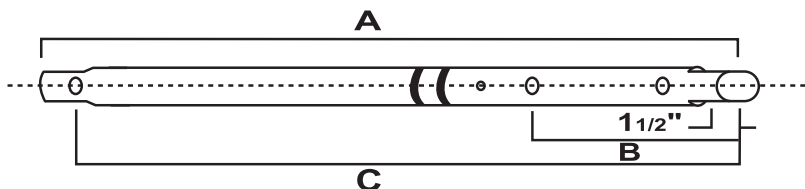

Model Number	When Used	Part Number	A	B	C
LG75	Before 1/2/90	⑤ XAV1919	18 7/8" (479.5)	5 13/16" (147.6)	17 3/8" (441)
EX75 & EXA75	Before 1/5/94	XAV05159A	18 7/8" (479.5)	5 13/16" (147.6)	17 3/8" (441)
LGS	After 1/5/94	XAV06625A	18 7/8" (479.5)	8 1/8" (206.4)	17 3/8" (441)

① XA03821A used in some models after July '87. Uses XA03878 Bevel Pinion.

② July '92 - April '94 Grooves in shaft ends for EXA model. Can also be used I.L.O. XAV1939 but Bevel Pinion must be changed to XA03878.

③ XA03823A used in some models after July '87. Uses XA03878 Bevel Pinion.

④ July '92 - April '94 Grooves in shaft ends for EXA model. Can also be used I.L.O. XAV1918 but Bevel Pinion must be changed to XA03878.

⑤ XAV1919 replaced by XAV05159A after July '92.



GO THE DISTANCE.

LANDING GEAR

Spare Parts

Chart #4
Single Speed Outer Leg

Travel Length	LG75 Before 1/2/90	EX75 & EXA75 1/2/90 to 1/5/94	LGS After 1/5/94
12 1/2"	XAV195000	XAV038750	XAV071320
13 1/2"	XAV195010	XAV038751	XAV071321
15"	XAV195020	XAV038752	XAV071322
16 1/2"	XAV195030	XAV038753	XAV071323
17 9/16"	XAV195040	XAV038754	XAV071324
18 5/8"	XAV195050	XAV038755	XAV071325

Chart #5
Two Speed Outer Leg

Travel Length	LG75 Before 1/2/90	EX75 & EXA75 1/2/90 to 1/5/94	LGS After 1/5/94
12 1/2"	XAV1925000	XAV037860	XAV071330
13 1/2"	XAV1925010	XAV037861	XAV071331
15"	XAV1925020	XAV037862	XAV071332
16 1/2"	XAV1925030	XAV037863	XAV071333
17 9/16"	XAV1925040	XAV037864	XAV071334
18 5/8"	XAV1925050	XAV037865	XAV071335



GO THE DISTANCE.

LANDING GEAR

Spare Parts

Chart #6

Inner Leg - Skid Foot, Wheeled & Rocker Foot

Travel Length	LG75 & EXA75	EX75	LGS
	Before 1/2/90 then 1/7/92 to 1/5/94	1/2/90 to 30/6/92	After 1/5/94
9 3/8"	XAV1963A0	XAV053560	XAV0662800
13 1/2"	XAV1963A1	XAV053561	XAV0662810
15"	XAV1963A2	XAV053562	XAV0662820
16 1/2"	XAV1963A3	XAV053563	XAV0662830
17 9/16"	XAV1963A4	XAV053564	XAV0662840
18 5/8"	XAV1963A5	XAV053565	XAV0662850

Chart #7

Inner Leg - Self-Levelling Foot

Travel Length	LG75 & EXA75	EX75	LGS
	Before 1/2/90 then 1/7/92 to 1/5/94	1/2/90 to 30/6/92	After 1/5/94
12 1/2"	XAV1960A0	XAV051200	XAV0662801
13 1/2"	XAV1960A1	XAV051201	XAV0662811
15"	XAV1960A2	XAV051202	XAV0662821
16 1/2"	XAV1960A3	XAV051203	XAV0662831
17 9/16"	XAV1960A4	XAV051204	XAV0662841
18 5/8"	XAV1960A5	XAV051205	XAV0662851



LANDING GEAR

Spare Parts
LGS Kits

Part Number	Description	Item Number	Required Parts	Qty
LK40	Bush Kit	45	XBLG0559	3
		46	XBLG1570	3
		56	XBV06622	2
		57	XBV07082	1
		58	XBLG065801	1
		23	XB02065	2
		15	XACRPV06634	1
		12	XB21S2181250	1
		11	XACRPV06633	1
		9	XBPP002002	1
		8	XBPP002301	1
		LK41	Bevel Gear Kit	26
33	XBV647			1
34	XAV06629			1
32	XBV06630			1
31	XBV06632			1
30	XACRPV06635			1
LK42	Drive Shaft Kit, Single Speed Leg	19	XAV06623A	1
		23	XB02065	1
		24	XAV06600	1
		25	XB01977	3
		45	XBLG0559	2
		46	XBLG1570	2
LK43	Drive Shaft Kit, Two Speed Leg	2	XAV06624A	1
		23	XB02065	1
		15	XACRPV06634	1
		24	XAV06600	1
		25	XB01977	3
		45	XBLG0559	1
		46	XBLG1570	1
		56	XBV06622	1
LK44	Crankshaft Kit	1	XAV06625A	1
		10	XAV066041	1
		11	XACRPV06633	1
		12	XB21S2181250	1
		9	XBPP002002	1
		8	XBPP002301	1
		58	XBLG065801	1
		56	XBV06622	1

Note: Item no. refers to item no. on (fig 1)



LANDING GEAR

Spare Parts
LGS Kits

Part Number	Description	Item Number	Required Parts	Qty
RKV063881	Hardware Kit, Leg Set	49	XBLG0085	1
		44	XAV1938	2
		54	XAV85	1
		51	XB1108	1
		18	XB338	3
		52	XBH332	1
		17	XBV4441	2
		55	XBV932	1
RKV796	Kit, Skid Foot, Landing	39A	XAV19011	2
		28A	XAV796WS	2
		41	XB21S3753000	4
RKV747	Kit, Wheel set, Landing Gear	39C	XAV19012	2
		41	XB21S3753000	4
		38D	XBV747	4
RKV818	Kit, Rocker Foot set, landing	39B	XAV19014	2
		38B	XAV818R	2
		41	XB21S3753000	4
RKE1019	Compensating Foot, L/G, C/W	(not shown)	34011	2
		(not shown)	XA60060	1
		(not shown)	XAE19011	1
		(not shown)	XB60066	4
RKV08332	Hardware Kit, Geared Leg only	44	XAV1938	1
		49	XBLG0085	1
		52	XBH332	1
		18	XB338	1
		51	XB1108	1
		54	XAV85	1
		55	XBV932	1

Note: Item no. refers to item no. on (fig 1)

LANDING GEAR

Spare Parts
LG700

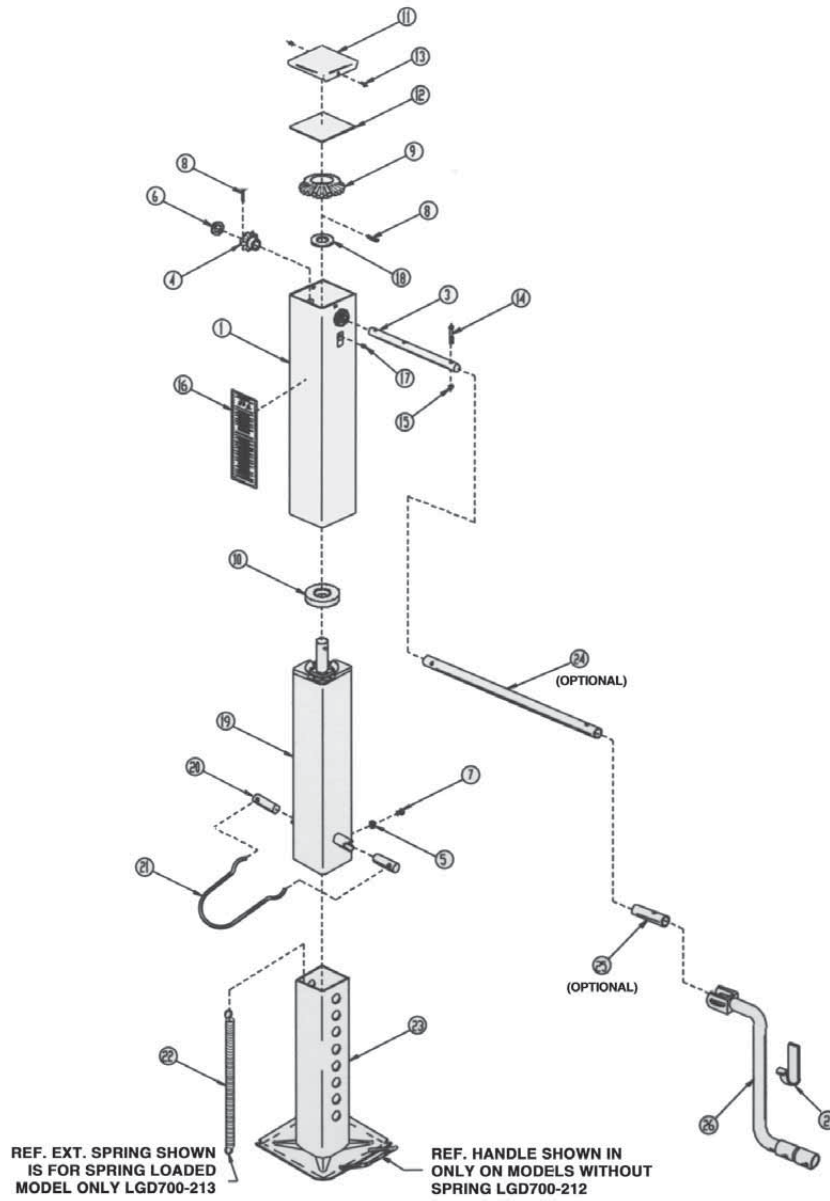



LANDING GEAR

Spare Parts
LG700

Section 4 - 4k

Item	Part Number	Description	Qty
1	LG158703	Upper housing	1
2	LG0085	Crank hanger	1
3	LG202001	Shaft drive	1
4	XBLG2026	Gear, pinion	1
5	XBPW01603	Washer, FL. 3/8 std. type A	1
6	XBPW01673	Washer, plain thrust .766 ID	1
7	XBSTS00817	Screw, self tap 3/8-16 x 7/16 hex	1
8	XBGP01407	Pin, groove type E 1/4 x 1-1/2	2
9	XBLG2027	Gear, bevel	1
10	XBBRG01370	Bearing thrust	1
11	XBLG0880	Top cover	1
12	XBLG0893	Cover Gasket	1
13	XBSTS00811	Self tap screw	2
14	XBHHC05042	Screw, hex, cap 3/8 x 2-1/4 GR.5	1
15	XBSLN01204	Self-locking nut	1
16	XBDCL03160	Decal, dual-pin	1
17	XBGRF02216	Grease fitting, 1/4-28	1
18	XBPW01651	Washer, plain 1.015 ID x 1.750 OD	1
19	LG2033	Retract tube & screw assembly	1
20	XBLG202401	Pin, locking	2
21	XBLG2006	Handle, spring	1
22	XBSPG02028	Spring, extension	1
23	LG200301	Ass'y., drop tube with handle	1
23	LG2003	Ass'y., drop tube without handle	1
24	LG2023	Tube crank extension	1
25	CP465116	Adaptor, crank	1
26	LG008301	Universal crank	1
27	LG2032	Retract tube and screw ass'y with drop section, spring loaded (not shown)	1
28	LG203201	Retract tube and screw ass'y with drop section, non-spring loaded (not shown)	1

LANDING GEAR

Spare Parts
LG5000

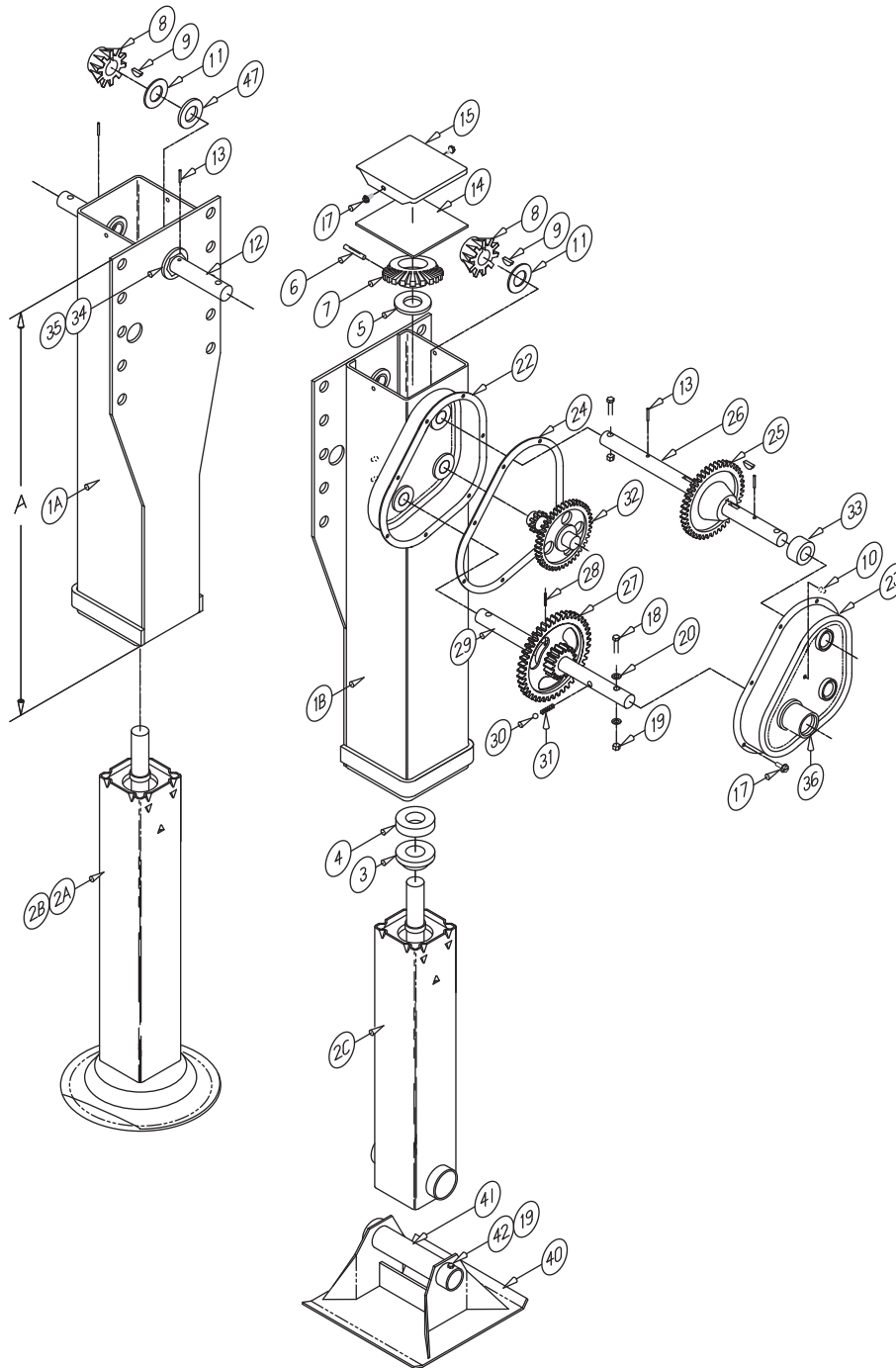



LANDING GEAR

Spare Parts
LG5000

Section 4 - 4m

Item	Part Number	Description	Qty
1A	N/A	Upper housing, L.H.	1
1B	N/A	Upper housing, R.H. w/gearbox half	1
2A	N/A	Retract tube ass'y. 10" dia. S.F.	2
2B	N/A	Retract tube ass'y. 12" dia S.F.	2
2C	N/A	Retract tube ass'y. axle socket	2
3	XBLG0544	Collar	2
4	XBBRG01377	Thrust bearing	2
5	XBPW01662	Washer	2
6	XBGP05221	Groove pin 3/8 x 2	2
7	XALG057001	Bevel gear	2
8	LG053102	Pinion gear	2
9	XBKEY01802	Woodruff key	3
10	XBGRF02216	Grease fitting, 1/4-28	5
11	XBPW01619	Thrust washer	2
12	LG0259	Jack shaft L.H. universal	1
13	XBSP01427	Spring pin 1/4 x 1 1/2	4
14	XBLG0413	Cover gasket	2
15	LG0264	Top cover	2
16	LG1430	Tag. date of manufacture (not shown)	2
17	XBSTS00811	Self-tapping screw	11
18	XBHHC05042	Screw, hex. cap 3/8-16 x 2 1/4	3
19	XBSLN01204	Self-locking nut 3/8-16	5
20	XBPW01603	Washer 3/8 std. type A	2
21	XBLG0668	Seal, gearbox to HSG (not shown)	1
22	XBLG0662	Gearbox half, inside	1
23	XBLG0663	Gearbox half, outside	1
24	XBLG0428	Gearbox gasket	1
25	LG054301	Output gear	1
26	LG0260	Jack shaft R.H. universal	1
27	LG0541-01	Input gear	1
28	XBGP01407	Groove pin, type E 1/4 x 1 1/2	1
29	LG026101	Shift shaft, universal	1
30	XBBAL02307	Shift lock ball, stainless stl.	1
31	XBSPG02036	Shift lock spring, galvanized	1
32	XBLG054201	Idler gear	1
33	XBLG021901	Spacer bushing	1
34	LG2094	Retainer, hex lock	3
35	LG2095	Boss, hex lock	3
36	XBLG065801	Shift lock boss	1
37	XBLG065901	Gearbox boss (not shown)	4
38	XBLG0660	Gearbox boss, inside half (not shown)	1
39	N/A	Gearbox ass'y., complete (not shown)	1
40	LG0055	Sandshoe 10 x 10 x 4 1/2 (code 1)	2
41	LG007002	Axle, sandshoe	2
42	XBHHC05069	Screw, hex cap 3/8-16 x 3/4	2
43	LG213006	Crank (not shown)	1
44	N/A	Cross drive shaft (not shown)	1
45	LG0266	Strut bracket (not shown)	2
46	XBLG0085	Crank hanger (not shown)	1
47	XBPW01614	Thrust washer, L.H.	1



GO THE DISTANCE.

RL250

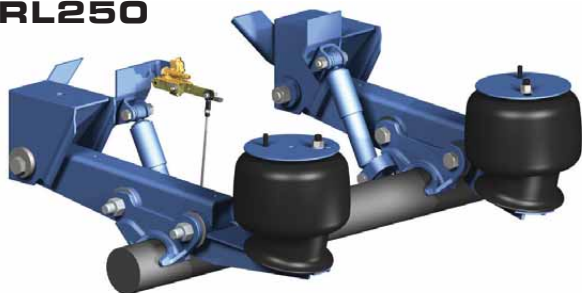

TRAILER SUSPENSION

RL300



SECTION 5

- Holland Air	1
- Neway	2
- Parts	3



GO THE DISTANCE.

HOLLAND AIR

Holland Air
Trailer Suspensions



GO THE DISTANCE.

TRAILER SUSPENSIONS

* 11,000 kg Capacity (Heavy Duty) Holland Air Kits

Recommended Spring Centres:

Dual wheel 920-980mm (based on use with an axle track of 1850mm [73"]).

Single wheel 1200-1300mm (based on use with an axle track of 2000mm) 10,000kg capacity.

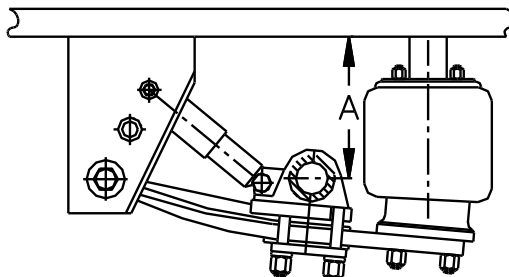

Part Number	Description	Ride Height Dimension A (mm)	Weight/ Module kg
H041	U/Slung	240-315	210-240
H042	O/Slung	490-575	210-240
H043	U/Slung	390-475	210-240

* 13,000 kg Capacity (Heavy Duty Plus) available on application

10,000 kg Capacity (Long) Holland Air Kits

Recommended Spring Centres:

Dual wheel 920-980mm (based on use with an axle track of 1850mm [73"]).

Single wheel 1200-1300mm (based on use with an axle track of 2000mm) 9,000kg capacity.

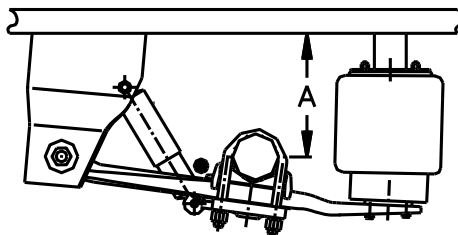

Part Number	Description	Ride Height Dimension A (mm)	Weight/ Module kg
L541	U/Slung	215-280	180-212
L541D	U/Slung	240-280	180-212
L541L	O/Slung	445-530	180-212
L542	O/Slung Cranked Spring	350-435	180-212

Notes:

1. Modules are supplied with Spring Seats to suit 127mm Round Beam Axle (Air Tank is not included).
2. For Air Suspension Options - see overleaf.
3. For Trailer Axles suitable for use with Air Suspension-see Trailer Axles Section.
4. In most cases no additional stroke limitation is necessary due to an internal stroke limitation facility within the shock absorber.

Note: No order for suspension and/or axle assemblies will be accepted without specifications sheets.
Use forms 1151HH, 1174HH or 1186HH.



GO THE DISTANCE.

TRAILER SUSPENSIONS

Holland Air Suspension ADR 38/01

Section 5 - 1b

Mass management approval number 2002.

Height Control Kits

To suit Single, Tandem, Tri & Quad axles. Prices on application.

Suspension Type	Axle Group	Approval Number
Holland Air	Single Axle	10898 SS
Holland Air	Tandem Axle	10897 SS
Holland Air	Tri-Axle	10896 SS
Holland Air	Quad-Axle	10257 SS

Options

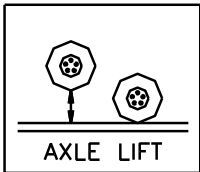
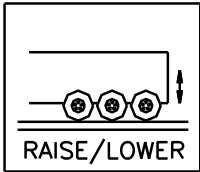
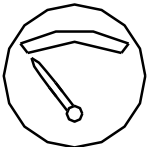
Product	Part Number	Description
	AL400	Dual Side Lift to suit Holland Euro/Ultra-Lite Series c/w Auto Drop Facility to suit Single Levelling Valve System
	AL138	Single Centre Lift to suit Holland Heavy Duty Series c/w Auto Drop Facility to suit Single Levelling Valve System
	CBL500	Single Centre Lift to suit Holland Neway c/w Auto Drop Facility to suit Single Levelling Valve System
	AL77	Single centre lift to suit Holland Neway RLU 228/250 C/W _ to drop facility to suit single levelling valve system.
	RL200	Raise/Lower Kit Single Levelling Valve System, suits Holland Air and Neway.
	WG300	Weight gauge kit, P.I.F. suit 12mm Airline.
	WG200	Weight gauge kit, suit Neway, 3/8" Airline.

Note: No order for suspension and/or axle assemblies will be accepted without specifications sheets.
Use forms 1151HH, 1174HH or 1186HH.



GO THE DISTANCE.

TRAILER SUSPENSIONS

Holland Air Suspension Order Specification Form

Delivery Address _____

Post Code _____

Date _____

Order No _____

Date Required _____

Job No _____

Transport _____

Step 1 SUSPENSION GROUPING / TRAILER TYPE

Please Specify

Single

Tandem

Tri-axle

Quad

Trailer Type

Step 2

SPRING CENTRES

Please Specify

mm

RIDE HEIGHT

Please Specify

mm

OPERATING LOCATION

Step 3 SUSPENSION MODEL

Long Series

10,00 kg's

L541

Under Slung

L541D

Under Slung

L541L

Over Slung

L542

Over Slung

Heavy Duty Series

11,000 kg's

H041

Under Slung

H042

Over Slung

H043

Under Slung

Step 4 OPTIONS

Please Specify

Yes

Pneumatic Kit

No

AD

Air Dump

RL

Raise/Lower

WG

Weight Gauge

AL138

Center Bag Lift

AL400

Side Bag Lift

1: Ride height dimension represents the distance from the centre of the axle to the underside of the chassis frame.

2: Use one form per trailer.

3: All steps must be completed.

Completed by: _____
(block letters please)

Axle Make/ Model: _____

Signed by: _____

Date: _____



GO THE DISTANCE.

HOLLAND NEWAY

Holland Neway
Trailer Suspensions



TRAILER SUSPENSIONS

10,250 kg Capacity (RLU228) Holland Neway Kits

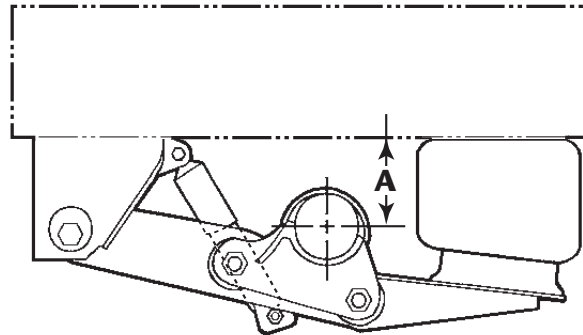

Part Number	Description	Ride Height	Ride Height Dimension A (mm)	Weight/ Module kg (Complete)
RLU-228	U/Slung	8"	203	164

10,250 kg Capacity (RL228) Holland Neway Kits

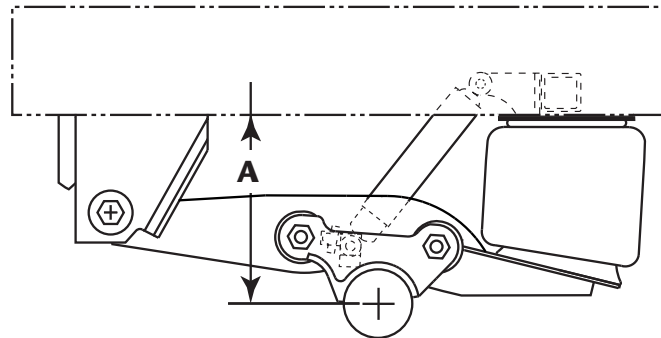

Part Number	Description	Ride Height	Ride Height Dimension A (mm)	Weight/ Module kg
RL-280-15	O/Slung	15"	380	158

Notes:

1. Modules are supplied with Spring Seats to suit 127mm Round Beam Axle (Air Tank is not included).
2. For Air Suspension Options - see overleaf.
3. For Trailer Axles suitable for use with Air Suspension-see Trailer Axles Section.

Note: No order for suspension and/or axle assemblies will be accepted without specifications sheets. Use forms 1195HH.



TRAILER SUSPENSIONS

11,340 kg Capacity (RLU250) Holland Neway Kits

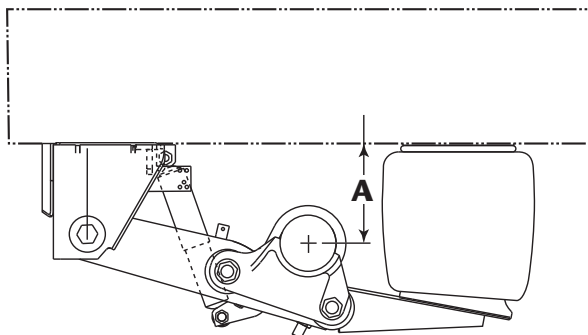

Part Number	Description	Ride Height	Ride Height Dimension A (mm)	Weight/ Module kg (Complete)
RLU-250	U/Slung	9"	228	164

11,340 kg Capacity (RL250) Holland Neway Kits

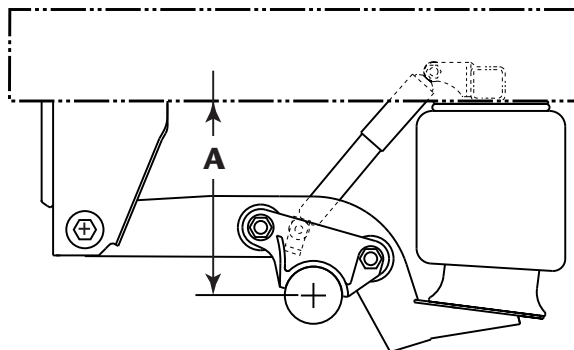

Part Number	Description	Ride Height	Ride Height Dimension A (mm)	Weight/ Module kg
RL-250-15	O/Slung	15"	380	162
RL-250-17	O/Slung	17"	430	168

Notes:

1. Modules are supplied with Spring Seats to suit 127mm Round Beam Axle (Air Tank is not included).
2. For Air Suspension Options - see overleaf.
3. For Trailer Axles suitable for use with Air Suspension-see Trailer Axles Section.

Note: No order for suspension and/or axle assemblies will be accepted without specifications sheets. Use forms 1195HH.



TRAILER SUSPENSIONS

13,610 kg Capacity (RLU300) Holland Neway Kits

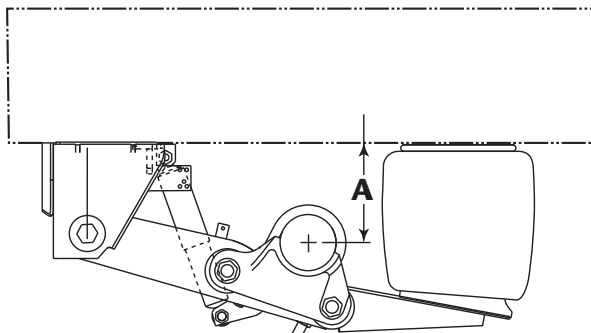

Part Number	Description	Ride Height	Ride Height Dimension A (mm)	Weight/ Module kg (Complete)
RLU-300	U/Slung	9"	228	135

13,610 kg Capacity (RL300) Holland Neway Kits

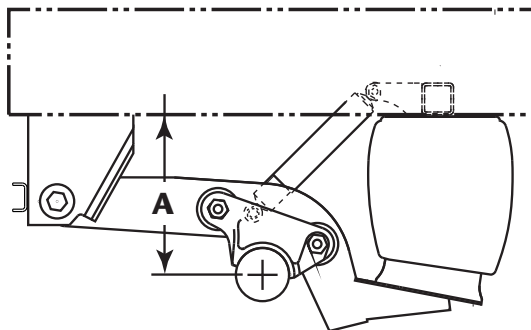

Part Number	Description	Ride Height	Ride Height Dimension A (mm)	Weight/ Module kg
RL-300-15	O/Slung	15"	380	166
RL-300-17	O/Slung	17"	430	170

Notes:

1. Modules are supplied with Spring Seats to suit 127mm Round Beam Axle (Air Tank is not included).
2. For Air Suspension Options - see overleaf.
3. For Trailer Axles suitable for use with Air Suspension-see Trailer Axles Section.

Note: No order for suspension and/or axle assemblies will be accepted without specifications sheets. Use forms 1195HH.

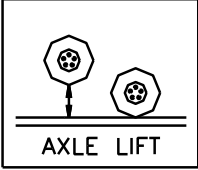
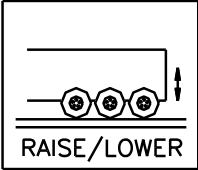
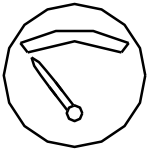
Product	Part Number	Description
	AL400	Dual Side Lift to suit Holland Euro/Ultra-Lite Series c/w Auto Drop Facility to suit Single Levelling Valve System
	AL138	Single Centre Lift to suit Holland Heavy Duty Series c/w Auto Drop Facility to suit Single Levelling Valve System
	CBL500	Single Centre Lift to suit Holland Neway c/w Auto Drop Facility to suit Single Levelling Valve System
	AL77	Single centre lift to suit Holland Neway RLU 228/250 C/W _ to drop facility to suit single levelling valve system.
	RL200	Raise/Lower Kit Single Levelling Valve System, suits Holland Air and Neway.
	WG300	Weight gauge kit, P.I.F. suit 12mm Airline.
	WG200	Weight gauge kit, suit Neway, 3/8" Airline.

Note: No order for suspension and/or axle assemblies will be accepted without specifications sheets.
Use forms 1195HH.



TRAILER SUSPENSIONS

Holland Neway Suspension Order Specification Form

Company	_____	Contact	_____
Delivery Address	_____		
Post Code	_____	Date	_____
Order No	_____	Date Required	_____
Job No	_____	Transport	_____

Step 1	SUSPENSION GROUPING / TRAILER TYPE
---------------	---

Please Specify

Single	Tandem	Tri-axle	Quad	Trailer Type

Step 2	
---------------	--

Please Specify

	RL228 Series 10,250 kg.	RL250 Series 11,340 kg.	RL300 Series 13,610 kg.		
	<input style="width: 40px; height: 30px;" type="text"/> <input style="width: 40px; height: 30px;" type="text"/>	<input style="width: 40px; height: 30px;" type="text"/> <input style="width: 40px; height: 30px;" type="text"/>	<input style="width: 40px; height: 30px;" type="text"/> <input style="width: 40px; height: 30px;" type="text"/>		
	RL228 O/Slung	RLU228 U/Slung	RL250 O/Slung	RLU250 U/Slung	RL300 O/Slung

Ride Height mm

Step 3	SUSPENSION MODEL
---------------	-------------------------

Please Specify

Yes	No	AD	RL	WG	CBL	EDL
Pneumatic Kit		Air Dump	Raise/Lower	Weight Gauge	Center Bag Lift	Side Bag Lift

Step 4	NOTES
---------------	--------------

- 1: Ride height dimension represents the distance from the centre of the axle to the underside of the chassis frame.
- 2: Use one form per trailer.
- 3: All steps must be completed.

Completed by: _____ <small>(block letters please)</small>	Axle Make/Model: _____
Signed by: _____	Date: _____

PLEASE RETURN FAX TO 03 9747 3895

Form No:
1195HH(c)



GO THE DISTANCE.

AD123



TRUCK SUSPENSION

ADTRIDEM



SECTION 6

- Single 1
- Tandem 2
- Tridem 3
- Parts



GO THE DISTANCE.

SINGLE AXLE

Single Axle
AD Series Truck Suspensions

Heavy-Duty Drive Axle
Air-Ride Suspensions
for Truck and Bus.



TRUCK SUSPENSIONS

Single Axle

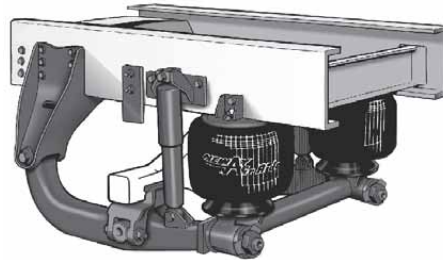

Part Number	Ride Heights ^①	Approx Susp. ^⑤ Weight	*GAWR	**GCWR	④ Site Travel Rating ^⑦ @ 110 PSIG Air Spring Pressure	Axle ^⑥ Travel		Multi ^③ Axle Spacing Min. - Max.	Max. Brake Chamber Size
						Total	Up		
AD-123	165mm (6.5")	216kg	10,433kg	-	13,721kg	145mm	74mm	1321-1524mm (52"-60")	3030
	222mm (8.75")					142mm	79mm		
	254mm (10")					145mm	69mm		
AD-126	222mm (8.75")	253kg	11,793kg	-	14,968kg	160mm	84mm	1346-1524mm (53"-60")	3030
	254mm (10")					168mm	76mm		
AD-130	222mm (8.75")	285kg	13,608kg	-	17,690kg	165mm	76mm	1549-1600mm (61"-63")	3636
	254mm (10")	294kg				165mm	89mm		
	305mm (12")	299kg				165mm	89mm		

① Ride heights should include imperial in bracket side due to High number of vehicles imported from USA & imperial still extensively used.

② AD-123/246 at 165mm (6.5") is only available with 18,144kg (40,000 lb.) capacity axles.

③ Contact Holland Applications Engineering for approval of axle spreads other than indicated.

④ For GCWR, consult OEM Applications Engineering. AD Series suspensions are less susceptible to the effects of high GCWR, due to their parallelogram design, than other drive train components. The AD Series suspension is typically not the limiting factor when calculating maximum GCWR.

⑤ Suspension weight does not include track bar, torque rod/axle brackets and axle adaptors.

⑥ Axle travel for AD-123/126 is listed for 7" (177.8mm) axle adapter drop. Axle travel for AD-130 is listed for 7.75" (196.8mm) axle adapter drop.

⑦ Vehicles equipped with liftable tag or pusher axles must not exceed published ratings when the tag and pusher axles are in their raised position (transfer of GVW to the steer and drive axles only).
Vehicle operation at these ratings is limited to no more than 5% of total vehicle operation and a maximum speed not to exceed 5 MPH (8 KPH). Site travel ratings for AD Series suspensions are limited to the load capacity of the air springs, based on an available 110 PSIG at the air springs.

* GAWR - Gross Axle Weight Rating

** GCWR - Gross Combination Weight Rating.



GO THE DISTANCE.

TANDEM AXLE

Tandem Axle
AD Series Truck Suspensions

Heavy-Duty Drive Axle
Air-Ride Suspensions
for Truck and Bus.



TRUCK SUSPENSIONS

Tandem Axle

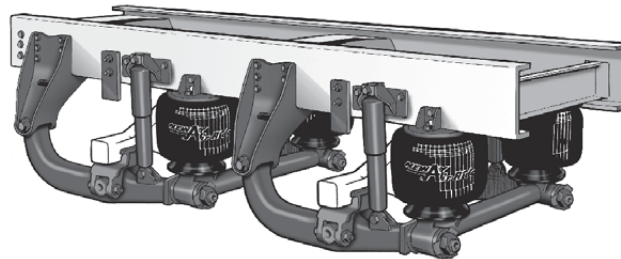

Part Number	Ride Heights ^①	Approx Susp. Weight ^⑤	*GAWR	**GCWR ^④	Site Travel Rating ^⑦ @ 110 PSIG Air Spring Pressure	Axle ^⑥ Travel		Multi ^③ Axle Spacing Min. - Max.	Max. Brake Chamber Size
						Total	Up		
AD-246	165mm (6.5")	433kg	20,865kg	-	27,433kg	145mm	74mm	1321-1524mm (52"-60")	3030
	222mm (8.75")					142mm	79mm		
	254mm (10")					145mm	69mm		
AD-252	222mm (8.75")	507kg	23,587kg	-	29,937kg	160mm	84mm	1346-1524mm (53"-60")	3030
	254mm (10")					168mm	76mm		
AD-260	222mm (8.75")	571kg	27,216kg	-	35,380kg	165mm	76mm	1549-1600mm (61"-63")	3636
	254mm (10")	589kg				165mm	89mm		
	305mm (12")	598kg				165mm	89mm		

① Ride heights should include imperial in bracket side due to High number of vehicles imported from USA & imperial still extensively used.

② AD-123/246 at 165mm (6.5") is only available with 18,144kg (40,000 lb.) capacity axles.

③ Contact Holland Applications Engineering for approval of axle spreads other than indicated.

④ For GCWR, consult OEM Applications Engineering. AD Series suspensions are less susceptible to the effects of high GCWR, due to their parallelogram design, than other drive train components. The AD Series suspension is typically not the limiting factor when calculating maximum GCWR.

⑤ Suspension weight does not include track bar, torque rod/axle brackets and axle adaptors.

⑥ Axle travel for AD-123/126 is listed for 7" (177.8mm) axle adapter drop. Axle travel for AD-130 is listed for 7.75" (196.8mm) axle adapter drop.

⑦ Vehicles equipped with liftable tag or pusher axles must not exceed published ratings when the tag and pusher axles are in their raised position (transfer of GVW to the steer and drive axles only).
Vehicle operation at these ratings is limited to no more than 5% of total vehicle operation and a maximum speed not to exceed 5 MPH (8 KPH). Site travel ratings for AD Series suspensions are limited to the load capacity of the air springs, based on an available 110 PSIG at the air springs.

* GAWR - Gross Axle Weight Rating

** GCWR - Gross Combination Weight Rating.



GO THE DISTANCE.

TRIDEM AXLE

Tridem Axle
AD Series Truck Suspensions

Heavy-Duty Drive Axle
Air-Ride Suspensions
for Truck and Bus.



GO THE DISTANCE.

TRUCK SUSPENSIONS

Tridem Axle

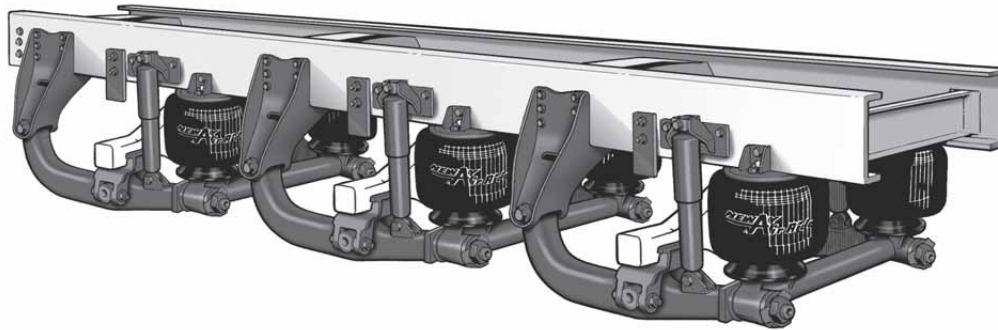

Part Number	Ride ① Heights	Approx Susp. ⑤ Weight	*GAWR	**GCWR ④	Site Travel Rating ⑦ @ 110 PSIG Air Spring Pressure	Axle ⑥ Travel		Multi ③ Axle Spacing Min. - Max.	Max. Brake Chamber Size
						Total	Up		
AD-369	165mm (6.5")	649kg	31,298kg	-	41,164kg	142mm	79mm	1321-1524mm (52"-60")	3030
	222mm (8.75") 254mm (10")					145mm	69mm		
AD-378	222mm (8.75") 254mm (10")	760kg	35,380kg	-	44,906kg	160mm	84mm	1346-1524mm (53"-60")	3030
						168mm	76mm		
AD-390	222mm (8.75")	857kg	40,824kg	-	53,070kg	165mm	76mm	1549-1600mm (61"-63")	3636
	254mm (10")	884kg				165mm	89mm		
	305mm (12")	898kg				165mm	89mm		

① Ride heights should include imperial in bracket side due to High number of vehicles imported from USA & imperial still extensively used.

② AD-123/246 at 165mm (6.5") is only available with 18,144kg (40,000 lb.) capacity axles.

③ Contact Holland Applications Engineering for approval of axle spreads other than indicated.

④ For GCWR, consult OEM Applications Engineering. AD Series suspensions are less susceptible to the effects of high GCWR, due to their parallelogram design, than other drive train components. The AD Series suspension is typically not the limiting factor when calculating maximum GCWR.

⑤ Suspension weight does not include track bar, torque rod/axle brackets and axle adaptors.

⑥ Axle travel for AD-123/126 is listed for 7" (177.8mm) axle adapter drop. Axle travel for AD-130 is listed for 7.75" (196.8mm) axle adapter drop.

⑦ Vehicles equipped with liftable tag or pusher axles must not exceed published ratings when the tag and pusher axles are in their raised position (transfer of GVW to the steer and drive axles only).

Vehicle operation at these ratings is limited to no more than 5% of total vehicle operation and a maximum speed not to exceed 5 MPH (8 KPH). Site travel ratings for AD Series suspensions are limited to the load capacity of the air springs, based on an available 110 PSIG at the air springs.

* GAWR - Gross Axle Weight Rating

** GCWR - Gross Combination Weight Rating.



GO THE DISTANCE.

SPARE PARTS

Spare Parts
Holland Truck Suspensions



SUSPENSIONS

Spare Parts Truck Suspensions Parts List AD-123 / 246 / 369 Series

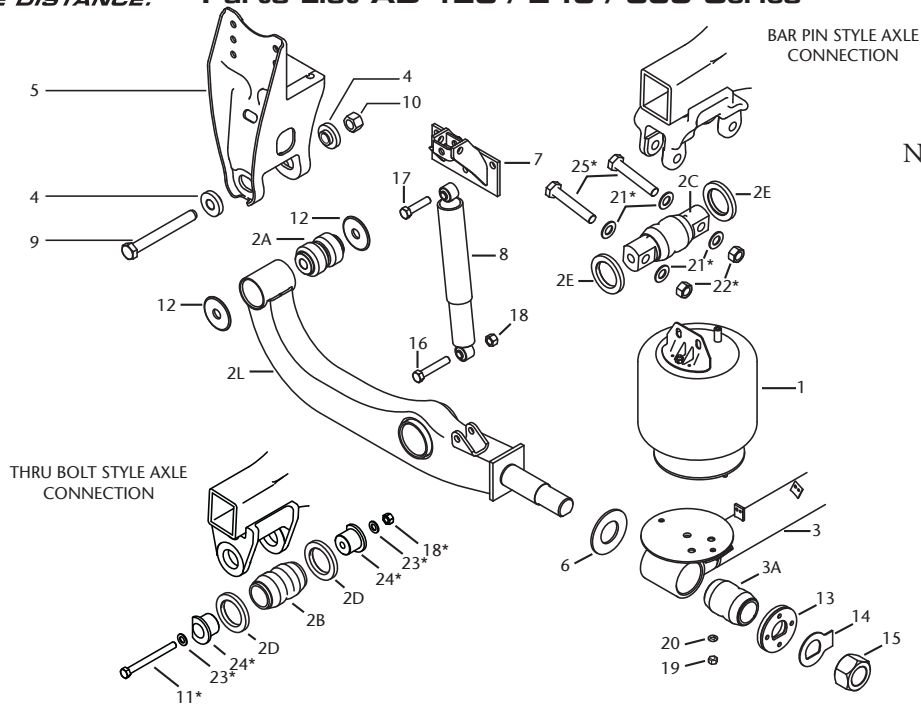

Note: Some parts may not be listed as they are generic to specific Truck Manufacturers. Please check with the manufacturer if unable to identify from the lists.

Item #	AD-123/246/369 Part No.	Description	Axle Groupings		
			Single Qty	Tandem Qty	Tridem Qty
1	**	Air Spring with mounting bracket	2	4	6
2L	**	Eq. Beam Assembly - Left Hand - Thru Bolt Design	1	2	3
2R	**	Eq. Beam Assembly - Right Hand - Thru Bolt Design	1	2	3
2L	**	Eq. Beam Assembly - Left Hand - Bar Pin Design	1	2	3
2R	**	Eq. Beam Assembly - Right Hand - Bar Pin Design	1	2	3
2A	900 08 252	Rubber Bushing - Front Pivot	2	4	6
2B	900 08 008	Bushing - Beam Center - Thru Bolt style	2	4	6
2C	900 08 175	Bushing - Beam Center - Bar Pin style	2	4	6
2D	900 01 065	Washer for Thru Bolt style connection	4	8	12
2E	900 01 205	Washer for Bar Pin style connection	4	8	12
3	905 45 997	Transverse Beam Assembly	1	2	3
3A	900 08 219	Bushing - Transverse Beam	2	4	6
4	900 08 120	Alignment Bushing (Qty. per adjustable bracket)	2	4	6
5	**	Frame Bracket - LH adjustable (requires item 4)	1	2	3
	**	Frame Bracket - RH fixed	1	2	3
6	906 00 498	Spacer Washer	2	4	6
7	**	Upper Shock Bracket	2	4	6
8	**	Shock Absorber	2	4	6
9	932 01 055	Hex Bolt 1-1/8" - 7 x 9.53	2	4	6
10	934 00 506	Hex Nut 1-1/8" - 7	2	4	6
11	*	Hex Bolt 3/4" - 10 x 7-1/2" (Thru Bolt Design only)	2	4	6
12	936 00 502	Washer - Pivot Spacer	4	8	12
13	905 36 006	Locking Spacer Assembly	2	4	6
14	936 00 533	Lock Tab Washer	2	4	6
15	934 00 607	Heavy Hex Nut 2-1/4" - 8	2	4	6
16	930 03 615	Cap Screw 3/4 - 10 x 4.25"	2	4	6
17	930 03 591	Cap Screw 3/4 - 10 x 3.25"	2	4	6
18	934 00 492*	Hex Nut 3/4"	2***	4***	6***
19	934 00 136	Hex Nut 1/2"	2	4	6
20	936 00 072	Lock Washer 1/2"	2	4	6
21	*	Washer Flat Narrow 1"	8	16	24
22	*	Hex Nut Lock 1"-8	4	8	12
23	*	Washer Flat Narrow (Thru) 3/4"	4	8	12
24	*	Bushing Adapter (Thru)	4	8	12
25	*	Cap Screw - 1 - 8 x 6 Gr. 8 (Bar Pin Only)	4	8	12

* Refer to OE/vehicle manufacturer build specifications to properly identify axle connection components.

** Refer to the OE/vehicle manufacturer's build specifications to properly identify the Holland Newway part numbers for the components noted with " ** ".

A serial tag may be affixed to the transverse beam that also denotes the Holland Newway kit number that will provide the individual component numbers needed.

*** The quantity shown is for a bar pin style unit. If a thru bolt style is used, increase the quantity by two per axle.



SUSPENSIONS

Spare Parts Truck Suspensions Parts List AD-126 / 252 / 378 Series

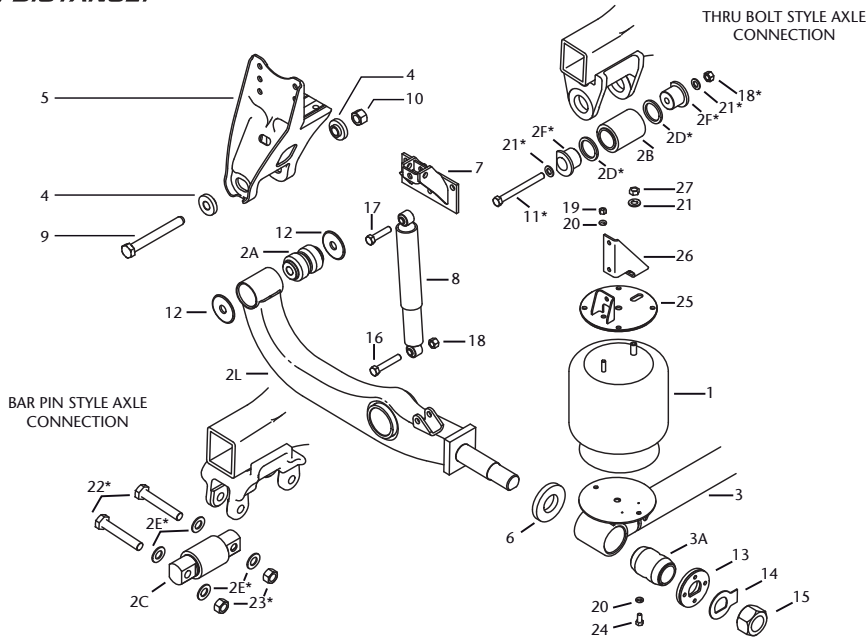

Note: Some parts may not be listed as they are generic to specific Truck Manufacturers. Please check with the manufacturer if unable to identify from the lists.

Item #	AD-126/252/378 Part No.	Description	Axle Groupings		
			Single Qty	Tandem Qty	Tridem Qty
1	**	Air Spring	2	4	6
2L	**	Eq. Beam Assembly - Left Hand - Thru Bolt Design (shown)	1	2	3
2R	**	Eq. Beam Assembly - Right Hand - Thru Bolt Design	1	2	3
2L	**	Eq. Beam Assembly - LH - Bar Pin Design (side view)	1	2	3
2R	**	Eq. Beam Assembly - Right Hand - Bar Pin Design	1	2	3
2A	900 08 252	Bushing - Front Pivot	2	4	6
2B	900 08 195	Bushing - Beam Center - Thru Bolt style	2	4	6
2C	905 08 012	Bushing - Beam Center - Bar Pin style	2	4	6
2D	*	Washer for Thru Bolt style connection	4	8	12
2E	*	Washer for Bar Pin style connection	8	16	24
2F	*	Adapter Bushing	4	8	12
3	905 45 987	Transverse Beam Assembly	1	2	3
3A	900 08 219	Bushing - Transverse Beam	2	4	6
4	900 08 120	Alignment Bushing (Qty. per adjustable bracket)	2	4	6
5	**	Frame Bracket - LH adjustable (Shown) (Requires Item 4)	1	2	3
	**	Frame Bracket - RH fixed	1	2	3
6	900 36 209	Washer	2	4	6
7	**	Upper Shock Bracket	2	4	6
8	**	Shock Absorber	2	4	6
9	932 01 055	Cap Screw 1.12 - 7 x 9.53"	2	4	6
10	934 00 506	Lock Nut 1.12 - 7	2	4	6
11	*	Cap Screw 3/4" - 10 x 7 1/2" (Thru Bolt Design only)	2	4	6
12	936 00 502	Washer - Pivot Spacer	4	8	12
13	905 36 006	Locking Spacer Assembly	2	4	6
14	936 00 533	Tab Washer	2	4	6
15	934 00 607	Heavy Nex Nut 2-1/4" - 8	2	4	6
16	930 03 615	Cap Screw 3/4 - 10 x 4.25"	2	4	6
17	930 03 591	Cap Screw 3/4 - 10 x 3.25"	2	4	6
18	934 00 492*	Lock Nut 3/4"	2***	4***	6***
19	934 00 136	Hex Nut 1/2"	2	4	6
20	936 00 072	Lock Washer 1/2"	6	12	18
21	*	Washer Flat Narrow 0.75	2	4	9
22	*	Bolt Hex 1 - 8x6 Gr 8	4	8	12
23	*	Nut Hex Lock 1 - 8	4	8	12
24	930 02 893	Bolt Hex 0.5 - 13x1 Gr 2	4	8	12
25	905 31 001	Air Spring Mounting Plate	2	4	6
26	900 23 131	Brace	2	4	6
27	*	Nut Hex Lock Thin .75 - 16 Gr A	2	4	6

* Refer to OE/vehicle manufacturer build specifications to properly identify axle connection components.

** Refer to the OE/vehicle manufacturer's build specifications to properly identify the Holland Newway part numbers for the components noted with " ** ". A serial tag may be affixed to the transverse beam that also denotes the Holland Newway kit number that will provide the individual component numbers needed.

*** The quantity shown is for a bar pin style unit. If a thru bolt style is used, increase the quantity by two per axle.



SUSPENSIONS

Spare Parts Truck Suspensions
Parts List AD-130 / 260 / 390 Series

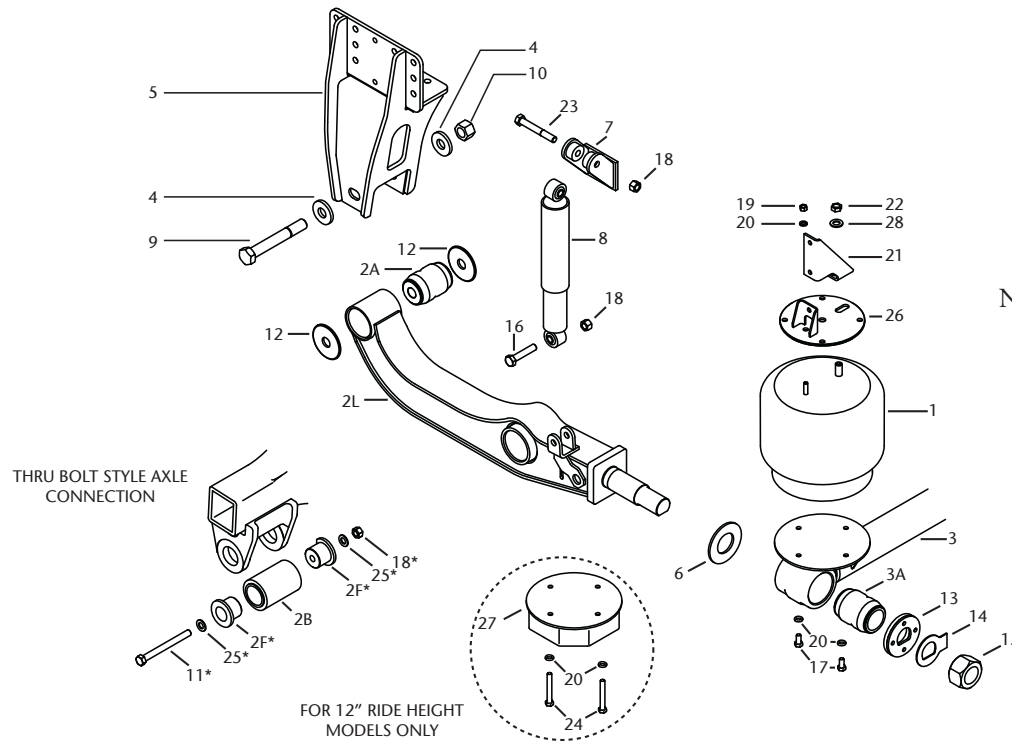

Note: Some parts may not be listed as they are generic to specific Truck Manufacturers. Please check with the manufacturer if unable to identify from the lists.

Item #	AD-130/260/390 Part No.	Description	Axle Groupings		
			Single Qty	Tandem Qty	Tridem Qty
1	**	Air Spring with mounting bracket	2	4	6
2L	905 16 963	Eq. Beam Assembly - Left Hand - Thru Bolt Design (shown)	1	2	3
2R	905 16 964	Eq. Beam Assembly - Right Hand - Thru Bolt Design	1	2	3
2A	900 08 256	Bushing - Front Pivot	0	4	6
2B	900 08 225	Bushing - Beam Center - Thru Bolt style	0	4	6
2F	*	Adapter Bushing	4	8	12
3	905 47 187	Transverse Beam Assembly	1	2	3
3A	900 08 135	Bushing - Transverse Beam	2	4	6
4	900 08 232	Alignment Bushing (Qty. per adjustable bracket)	2	4	6
5	**	Frame Bracket - LH adjustable (Shown) (Requires Item 4)	1	2	3
	**	Frame Bracket - RH fixed	1	2	3
6	936 00 498	Washer	2	4	6
7	**	Upper Shock Bracket	2	4	6
8	**	Shock Absorber	2	4	6
9	932 01 068	Cap Screw 1.25 - 7 x 9"	2	4	6
10	934 00 510	Lock Nut 1.25 - 7	2	4	6
11	*	Cap Screw 3/4" - 10 x 8.00" (Thru Bolt Design only)	2	4	6
12	936 00 546	Washer - Pivot Spacer	4	8	12
13	905 36 006	Locking Spacer Assembly	2	4	6
14	936 00 533	Tab Washer	2	4	6
15	934 00 607	Heavy Nex Nut 2-1/4" - 8	2	4	6
16	930 03 603	Cap Screw 3/4 - 10 x 3.75"	2	4	6
17	930 02 893	Cap Screw 1/2 - 13 x 1"	4	8	12
18	934 00 492*	Lock Nut 3/4"	6	12	18
19	934 00 136	Hex Nut 1/2"	2	4	6
20	936 00 072***	Lock Washer 1/2"	6	12	18
21	900 23 131	Brace Angle	2	4	6
22	934 00 417	Hex Nut Thin - 0.75" - 16 Gr A	2	4	6
23	930 03 645	Cap Screw 3/4 - 10 x 5.5"	2	4	6
24	930 02 961	Bolt Hex 0.5-13 x 3.75 Gr 5 - for 12" ride height models only	4	8	12
25	*	Washer Flat Narrow 0.75	4	8	12
26	905 31 001	Plate Air Spring Mounting Upper	2	4	6
27	905 36 009	Spacer Air Spring Assembly - for 12" ride height models only	2	4	6

* Refer to OE/vehicle manufacturer build specifications to properly identify axle connection components.

** Refer to the OE/vehicle manufacturer's build specifications to properly identify the Holland Newway part numbers for the components noted with " ** ".

A serial tag may be affixed to the transverse beam that also denotes the Holland Newway kit number that will provide the individual component numbers needed.

***For 12" ride height models, increase quantity by 4 per axle.



GO THE DISTANCE.

SUSPENSIONS

Spare Parts Truck Suspensions
Service Repair Kits (SRK)

Section 6 - 4d

Pivot Connection

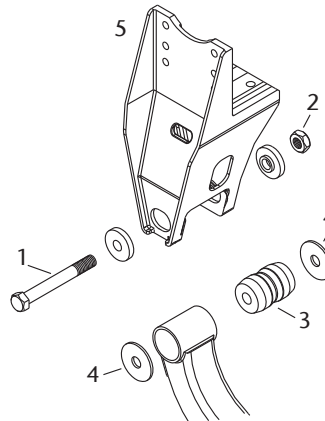

NOTE: New alignment bushings recommended when alignment bushing surface become deformed. Refer to parts list.

NOTE: Item 4 is not used on former Ford production units.

Part Number	Description	Item Number	Required Parts	Qty
SRK-200: 481 00 260	Pivot Connection - AD123 & AD126 Series	1	932 01 055	2
		2	934 00 506	2
		3	900 08 151	2
		4	936 00 502	4
SRK-499: 481 00 363	Pivot Connection - AD130 Series	1	932 01 068	2
		2	934 00 510	2
		3	900 08 226	2
		4	936 00 547	4

Transverse Beam Connection

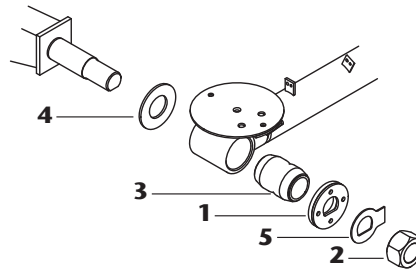

Part Number	Description	Item Number	Required Parts	Qty
SRK-214: 481 00 276	Transverse Beam Connection - AD123 Series	1	905 36 006	2
		2	934 00 607	2
		3	900 08 219	2
		4	936 00 498	2
		5	936 00 533	2
SRK-472: 481 00 335	Transverse Beam Connection - AD126 Series	1	905 36 006	2
		2	934 00 607	2
		3	900 08 219	2
		4	900 36 209	2
		5	936 00 533	2
SRK-500: 481 00 364	Transverse Beam Connection - AD130 Series	1	905 36 006	2
		2	934 00 607	2
		3	900 08 135	2
		4	936 00 498	2
		5	936 00 533	2



SUSPENSIONS

Spare Parts Truck Suspensions
Service Repair Kits (SRK)

Axle Bar Pin Connection

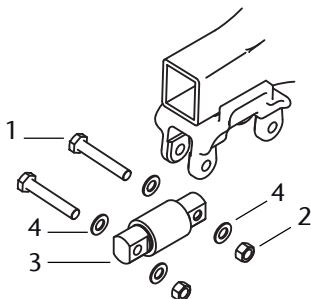

NOTE: The AD130 Series does not utilize the bar pin connection.

Part Number	Description	Item Number	Required Parts	Qty
SRK-450: 481 00 313	Axle Bar Pin Connection - AD126 Series	1	930 04 301	4
		2	934 00 502	4
		3	905 08 175	2
		4	936 00 168	8

Axle Thru Bolt Connection

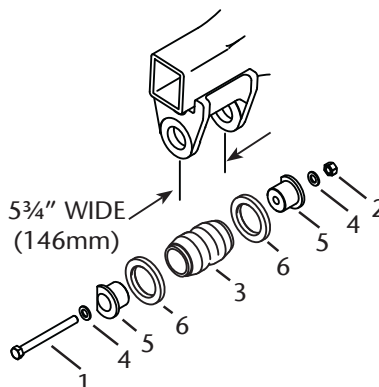

Part Number	Description	Item Number	Required Parts	Qty
SRK-80: 481 00 124	Axle Thru Bolt Connection - AD123 Series	1	930 03 693	2
		2	934 00 492	2
		3	900 08 008	2
		4	936 00 156	4
		5	900 01 002	4
		6	900 01 065	4

Conditions of Sale



1. Interpretation

“Company” means Holland Hitch (Aust.) Pty. Ltd. “Customer” means the person to or for whom Goods are supplied by the Company. “Delivery Date” has the meaning given in clause 4(b). “Goods” means the goods, which are the subject matter of these terms. “Implied Warranties,” mean any term, condition or warranty implied law.

2. Operation

- (a) All orders for and supply of Goods shall be governed by these conditions of sale.
- (b) A Customer shall be deemed to have accepted these conditions of sale by placing an order with the Company.

3. Orders

- (a) The Customer may order Goods only by completing the order forms approved by the Company from time to time.
- (b) The Company is not obliged to accept any order for Goods. The Company may accept an order only by notifying the Customer in writing or by delivering the Goods described in the order to the Customer or to a carrier.
- (c) The Customer authorises the Company to complete any uncompleted order form received from the Customer and agrees to be bound by the terms of such a completed order form.
- (d) The Customer cannot cancel an order, which has been accepted by the Company, without prior written consent of the Company. The Customer acknowledges that if the Company accepts the cancellation, the Company may charge a cancellation fee.

4. Delivery and Risk

- (a) Delivery of goods is conditional upon availability. The Customer acknowledges that the Company shall be under no liability for late delivery.
- (b) Delivery shall be deemed to take place at the time of physical taking of the Goods by the Customer or by a carrier whether engaged by the Company or by the Customer (“Delivery Date”).
- (c) Goods shall be at Customer’s risk on and from the Delivery Date.
- (d) Subject to Implied Warranties, which are not capable of exclusion or limitation, the Company’s responsibility for damage or shortage ceases on and from the Delivery Date.
- (e) All delivery and return costs shall be borne by the Customer, unless otherwise specified.

5. Prices and Payment

- (a) The provision of a price list is not to be construed as an offer to sell.
- (b) Prices are subject to withdrawal or change without notice.
- (c) If partial delivery is made proportionate payment shall apply. If the Customer is in breach of any obligation, the Company has the right not to fulfil any unexecuted part orders.
- (d) The prices charged for the Goods will be those ruling at the Delivery Date.
- (e) Unless stated to the contrary, prices do not include taxes, duties, levies, imports or charges for which the Customer will be responsible.
- (f) The Company may recover from the Customer interest on any unpaid amounts at a rate (set out on the invoice).
- (g) Subject to clause 5(h) payment of the full purchase price for the Goods is due and payable within 30 days of the date specified on the invoice.
- (h) The full purchase price for the Goods shall become immediately due and payable if the Customer, takes or has taken or instituted against it any action or proceeding whether voluntary or compulsory which has object or may result in the bankruptcy or winding up of the Customer (other than a voluntary winding up for the purposes of amalgamation or reconstruction) or is placed under official management or a receiver, receiver and manager or administrator is appointed over the whole or any part of its undertaking or the Customer is unable to pay its debts if and when they fall due.

6. Returns

- (a) Subject to any Implied Warranties which are not capable of exclusion or limitation, credit will not be issued for Goods returned unless the Company believes it appropriate, and:
 - i. Invoice numbers are quoted; and
 - ii. The Customer notifies the Company immediately on receipt of Goods.
- (b) Subject to any Implied Warranties which are not capable of exclusion or limitation, credit will not be issued for Goods made to order.
- (c) The Customer must provide the reasons for return upon request by the Company.
- (d) Subject to any Implied Warranties which are not capable of exclusion or limitation, a penalty restocking fee of 15% of the value of the goods being returned will be charged on all goods returned after the expiration of 30 days from the original delivery date.

- (e) Subject to any Implied Warranties, which are not capable of exclusion or limitation, no goods will be returned without the customer firstly obtaining goods return number from the Company.
- (f) Subject to any Implied Warranties, which are not capable of exclusion or limitation, no goods will be accepted as being returned for credit upon the expiration of six (6) calendar months from the original delivery date.

7.Risk and Insurance

- (a) The Customer at its own expense must insure Goods on and from the Delivery Date.

8.Property

- (a) Title to Goods remains in the Company until:
 - i. The full purchase price and all other sums payable by the Customer to the Company in respect of the Goods are paid; or
 - ii. The Customer sells or disposes of the Goods to its customers in the ordinary cause of business.
- (b) While title to the Goods remains in the Company, the Customer shall have no ownership or rights in the Goods and shall, while possesses of the same, hold only as a mere bailee for the Company.
- (c) Until the full purchase price and all other sums payable by the Customer to the Company in respect of the Goods are paid the Customer shall store the Goods separately so that they are clearly identifiable and shall label the Goods in a way which clearly manifests the Company's title (and shall not transform the Goods or incorporate the Goods into other products).
- (d) Notwithstanding anything in this clause the Customer may sell or dispose of the Goods to its customers in the ordinary course of business in which case the Customer shall:
 - i. Hold the process of sale for the Company and shall not mix any of the proceeds of sale with its own money but shall ensure that all receipts are kept separate and identifiable; and
 - ii. Where requested by the Company assign to the Customer the benefit of any claim against a third party.
- (e) If the Customer fails to pay the full purchase price for the Goods by the due date and the Goods are in the Customer's possession or control, the Company or its representative may enter the Customer's premises or any premises where the Company reasonably believes the Goods are kept and remove the Goods and the Customer shall assist and indemnify the Company in relation to such removal.

9.Packaging

The Company recommends that deliveries to country areas be packed in timber crates to prevent transit damage.

10.Warranties

- (a) If the liability of the Company to the Customer for any breach of any Implied Warranty is capable of exclusion it is excluded.
- (b) If the liability of the Company to the customer for any breach of any Implied Warranty is capable of limitation it is limited to resupplying or replacing the Goods.
- (c) Subject to any Implied Warranties which are not capable of exclusion or limitation:
 - i. The Company makes no warranties in relation to the Goods;
 - ii. The Company, its servants, agents and contractors shall not be liable for any loss, damage or injury (including without limitation any loss of profit, indirect or consequential loss) arising from the supply or use of the Goods or for any act or omission (including negligence) of the Company;
 - iii. The Customer indemnifies the Company from any loss, damage or injury resulting from any claims or demands by any third party relating in any way to the Goods.
- (d) These conditions of sale supersede and exclude all prior and other discussion and arrangements relating to the supply of the Goods.

11.General

- (a) Special conditions embodied in Customer's orders are not considered binding unless specifically agreed to in writing by the Company.
- (b) These conditions of sale are governed by the law of Victoria and the Customer agrees to submit to the jurisdiction of Victorian courts and tribunals.
- (c) Subject to any Implied warranties which are not capable of exclusion or limitation, the Company reserves the right to charge a restocking fee of 15%.
- (d) The Customer acknowledges that the minimum amount of any order is \$100.00.
- (e) The Customer acknowledges some Goods are not kept as stock lines. It is the Customer's responsibility to check lead times for Goods they have ordered.



COMMERCIAL PRODUCTS WARRANTY

HOLLAND HITCH (AUST.) PTY. LTD. warrants all Commercial Products (products other than those normally used for personal, family or house hold purposes) manufactured by it, when properly installed, to be free from defects in material and workmanship under normal use and service for a period of one (1) year from the date of manufacture, with the exception of the FW351/FW342 (not including attached Bases and Balltraces) fifth wheel that have 2 years and the elevating fifth wheels for which the warranty period is ninety (90) days.

The warranty is void with respect to any product which has been altered in any way from its manufactured condition, such as intentional modification, accident, corrosion, misuse failure to provide necessary and reasonable maintenance and is exclusive of normal wear.

The sole responsibility of HOLLAND under this warranty is limited to repairing or replacing at the factory any part or parts which are returned, with transportation charges prepaid, and are found to be defective to the satisfaction of HOLLAND. Written authorization from HOLLAND must be obtained prior to returning any part or parts. No charges for transportation or for labour performed on Holland products by unauthorized persons will be allowed under this warranty. HOLLAND shall not be liable, in any event, for proximate, incidental, consequential or other damages, including but not limited to damages for loss of production or injury to persons or property arising out of any breach of this warranty.

THERE ARE NO WARRANTIES, EXPRESSED OR IMPLIED, INCLUDING THE WARRANTY OF MERCHANTABILITY OR A WARRANTY OF FITNESS FOR A PARTICULAR PURPOSE EXTENDING BEYOND THAT SET FORTH ABOVE.

HOLLAND reserves the right, without prior notice, to change specifications and dimensions as designs are altered and/or improved.

Options and features other than those shown may be provided.



GO THE DISTANCE.



GO THE DISTANCE.

THE HOLLAND GROUP, INC.
467 Ottawa Avenue P.O. Box 2099 Holland, MI 49422-2099
www.thehollandgroupinc.com

Copyright © May 2006 Holland Hitch (Aust.) Pty. Ltd.
www.hollandhitch.com.au



Quality
Endorsed
Company

ISO 9001:2000 L1 1996
SAS Global

Holland Hitch (Aust.) Pty. Ltd.
A.B.N. 79 004 371 215
P.O. Box 63 - 115 High Street
MELTON VIC 3337
Ph: (03) 9743 6799
Fax: (03) 9743 6763

Western Region
Unit 2 - 511 Abernethy Road
KEWDALE WA 6105
Ph: (08) 9353 6122
Fax: (08) 9353 6144

Northern Region
12 Pradella Street
DARRA QLD 4076
Ph: (07) 3375 7033
FAX: (07) 3375 7044

Eastern Region
Unit 4-13 McCormack Street
ARNDILL PARK NSW 2148
Ph: (02) 9672 1950
FAX: (02) 9672 1994