



FIFTH WHEELS

SERVICE BULLETIN

Holland HITCH

Out of service inspection for
FW3500 / FW351 / FW342 / FW70
Fifth Wheels
19 March 2002

VERTICAL MOVEMENT OF TOP PLATE

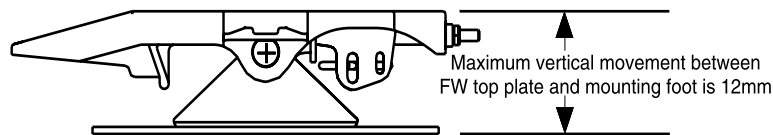

To determine the amount of movement between the fifth wheel top plate and the mounting foot, place a bar beneath the pivot pin lobe on the casting and slowly apply pressure to the bar to take up the free clearance only. It is important to note that the pivot bush is constructed from a soft medium and will compress, do not compress the bush when taking your measurement.

WEAR LIMITS

Fifth wheel top plate to fifth wheel rocker feet (mounting brackets)
Horizontal movement - 3mm forward and rear of centre

Fifth wheel top plate inner foot pocket wear - 3mm
mounting bracket wear - 3mm

Single row ballrace - Vertical Lift (axial movement) - 2mm
Horizontal (radial movement) - 3mm

Double row ballrace - Vertical Lift (axial movement) - 3.5mm
Horizontal (radial movement) - 3mm

PIVOT PIN & BORE

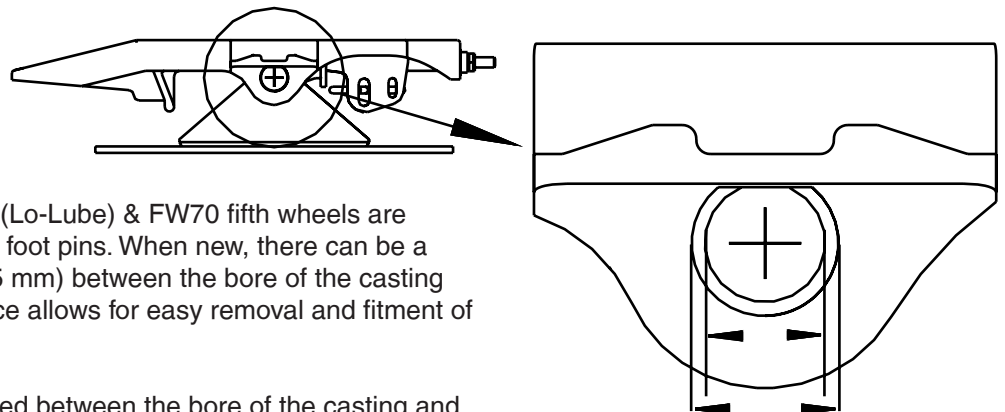

Holland Hitch FW351, FW342 (Lo-Lube) & FW70 fifth wheels are manufactured with loose fitting foot pins. When new, there can be a clearance of up to 0.033" (0.85 mm) between the bore of the casting and the pivot pin. This clearance allows for easy removal and fitment of the foot pin in the field.

The maximum clearance allowed between the bore of the casting and the pivot pin is 0.125" (3.2mm).

0.125" (3.2 mm) Maximum clearance
between casting bore and a new foot pin.

HORIZONTAL MOVEMENT

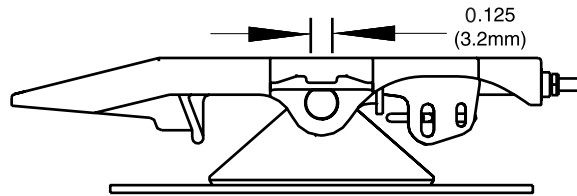

If the horizontal (fore & aft) movement between the fifth wheel locking jaws and a Holland lock tester exceeds 0.125" (3.2mm) the fifth wheel locking jaws require adjustment.

If the locking jaws cannot be adjusted to the point where resistance is felt when rotating the lock tester, new lock jaws need to be fitted.

ALL SERVICE AND ADJUSTMENT PROCEDURES CAN BE FOUND IN THE SERVICE ICON AT
www.hollandhitch.com.au



GO THE DISTANCE.

HOLLAND HITCH (AUST.) PTY. LTD.
P.O. Box 63 Melton, Vic 3337 Phone: (03) 9743 6799 Fax: (03) 9743 6763
www.hollandhitch.com.au



Quality
Endorsed
Company

ISO 9001:2000 Lic. 1995
Standards Australia