

SAF Parallel (P-Style) Spindle Axles

Product Change Notification – Drum Brake Axles Only

Effective Immediately

Attention

SAF-HOLLAND will be implementing a product change to all SAF branded drum brake axles with parallel spindles. The axle spindles will no longer be cross drilled for cotter pin insertion for standard production. Cross drilled P-spindles are still available as an option.

With the market acceptance of new spindle nut technology and systems, these cross drilled holes are no longer necessary. The elimination of the drilled holes will increase overall product quality due to the removal of potential burrs and other drilling issues.

Engineering will be creating new part numbers. The change is being implemented by product line over the next six months.

If you have any questions or require additional product assistance, please contact your account manager or customer service representative.

OLD DESIGN

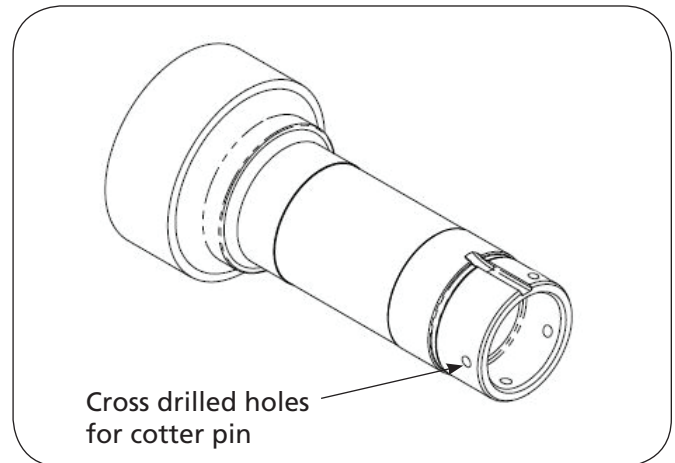

NEW DESIGN

