

NEWAY

MODELS:

AD-160

AD-200

Drive Axle Air Suspension

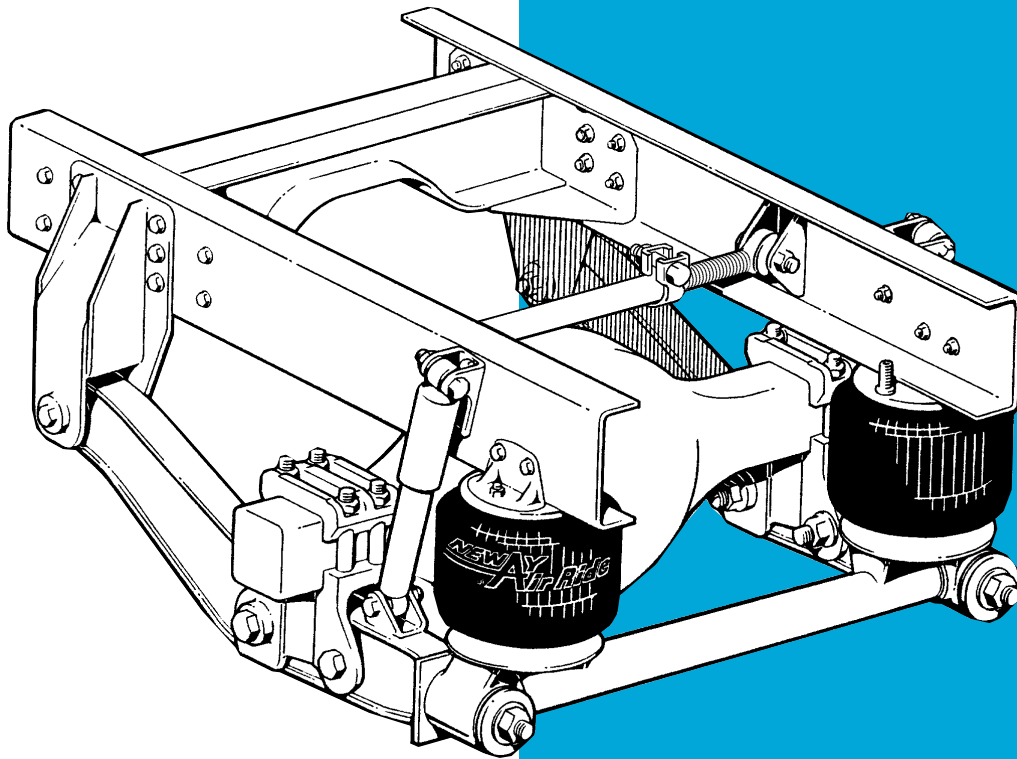

MAINTENANCE MANUAL

THIS MANUAL MUST ACCOMPANY THE VEHICLE TO THE END USER.

VEHICLE REFERENCE INFORMATION

NOTE:

This manual applies to the suspension models or series shown and for special orders of the same. It is very important to determine your specific model number, serial number and parts list number. Write those numbers here, and refer to them when obtaining information or replacement parts.

NOTE:

REFER TO SERIAL NUMBER PLATE ATTACHED TO THE TRANSVERSE BEAM FOR INFORMATION.

MODEL NUMBER _____

SERIAL NUMBER _____

PARTS LISTS NUMBER _____

IN SERVICE DATE _____

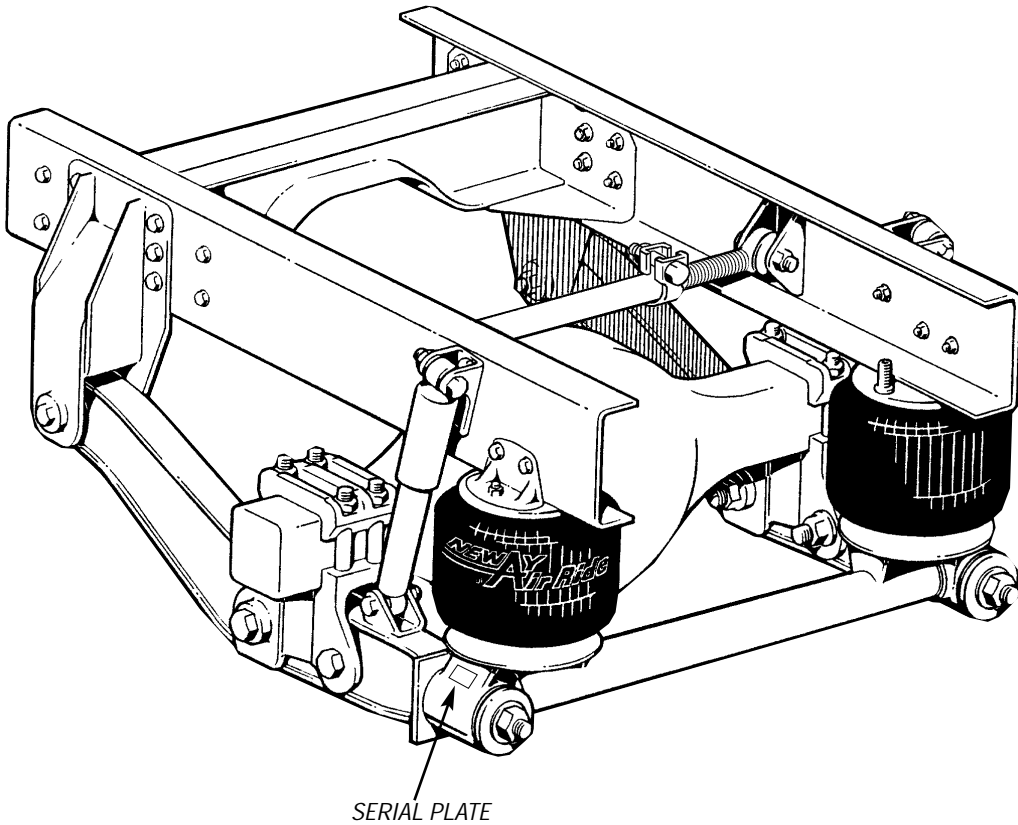

CONTENTS

Introduction	3
Warranty.....	3
Operating Instructions and Maintenance Instructions	4
Pre-Operational Checklist	5
Parts Lists	6
Type CR (Controlled Response) Height Control Valve Information	7
Type CR HCV Control Parts Lists	8
Type CR Flexible Link Assembly.....	9
Type IR (Immediate Response) Height Control Valve Information	10
Type IR HCV Control Parts Lists	11
Type IR Flexible Link Assembly	12
Pressure Protection Valve and Filter	12
Service Repair Kits.....	13
Frame Bracket Replacement Instructions.....	13
Component Replacement Instructions.....	14
Trouble Shooting.....	15

INTRODUCTION

This manual gives you information necessary for the care, maintenance, inspection, and safe operation of Neway's Series, drive axle air suspension models specified.

The Neway Air Suspension is designed and engineered to provide trouble-free service. In the event of minor breakdown, such as a loss of air in the air springs, there are safety features designed into the suspension that will allow the vehicle to be driven CAUTIOUSLY at slow speed, to the nearest service facility. Be sure tires are not rubbing underside of any object.

This suspension uses air drawn from the air system to pressurize the air springs. The height control valve regulates the air pressure required for varying loads and maintains a constant ride height. This suspension can provide a cushioned ride throughout the load range, from empty to fully loaded. The suspension also provides excellent side-to-side and axle-to-axle loading which helps equalize and control braking.

NOTES, CAUTIONS, AND WARNINGS

Throughout this manual, you will notice the terms "NOTE", "IMPORTANT", and "CAUTION" followed by important product information. So that you may better understand the manual, those terms are defined.

NOTE:

is used as a reminder of an instruction where the concern deals with product integrity and has to do with installation, operation, maintenance or service and care of the product.

IMPORTANT:

is with product integrity and has to do with installation, operation, maintenance or service and care of the product. It is intended to show that vehicle breakdown and/or expensive repair could result if the instruction is not followed.

CAUTION:

is used with an instruction for the distinct purpose of showing that a safe practice must be adhered to or that an unsafe practice must be avoided, and that if proper precautions are not taken, personal injury could result.

WARRANTY

Neway Anchorlok International, Inc. warrants its products manufactured and supplied by it for coverage periods of

Major Components -

Up to 36 months or 250,000 miles, whichever occurs first.

Other Components -

Up to 12 months or 100,000 miles, whichever occurs first.

Refer to the complete warranty for the country in which the product will be used. A copy of the written warranty is included with the product. It may also be ordered directly from the address shown on the back cover. The information contained on this page does not in and of itself constitute a warranty.

NOTE: This manual applies to the suspension models or series shown and for special orders of the same. It is very important to determine your specific model number, serial number and parts list number. Write those numbers in the inside front cover, and refer to them when obtaining information or replacement parts.

NEWAY Drive Axle Air Suspension Operation

The NEWAY Drive Axle Air Suspension is controlled by a single "Type CR" or "Type IR" height control valve. Properly adjusted, it will maintain the desired ride height throughout the unloaded to loaded range automatically. The height control valve automatically adds air to, or exhausts air from the air suspension to maintain a constant design height. The Type CR HCV does not respond to short duration dynamic changes in axle position, while the Type IR does.

Before putting the vehicle in operation, build air pressure in excess of 70 P.S.I. This will open the pressure protection valve, and allow air flow to the height control valve.

RECOMMENDED INSPECTIONS AND ROUTINE MAINTENANCE

Daily Inspection

Daily or before each trip, check the suspension to be sure it is fully operational. Visually inspect air springs for sufficient and equal pressure and to see that suspension is set at proper ride height. See page 7 for ride height measurement and re-setting instructions. Service as necessary.

Initial 5,000 Mile (8,000 KM) Inspection

1. After initial 5,000 miles (8000 KM) Inspect bolts and nuts at the pivot and axle connections to assure they are properly torqued. Check all other nuts and bolts for proper torque. Re-torque as necessary thereafter.
2. With vehicle on level surface and air pressure in excess of 70 P.S.I.G., all air springs should be of sufficient and equal firmness to maintain the suspension ride height.

NOTE: Height control valve controls all air springs. Check all fittings for air leaks, by applying a soapy solution, checking for bubbles at all air connections and fittings.

3. Suspension ride height (underside of frame to centerline of axle) **MUST BE WITHIN $\pm 1/4$ " OF RECOMMENDED DESIGN HEIGHT.** Improper ride height could result in a poor ride or damage to the suspension and erratic vehicle handling. See page 7 for instructions on measuring ride height.

Routine Maintenance - 50,000 Miles (80,000 KM) or 1 year min. or as needed

At 50,000 miles (80,000 KM) or 1 year, or when servicing vehicle brake system, inspect suspension components per 5,000 mile (8,000 KM) inspection. Also check all other suspension components for any sign of damage, looseness, wear or cracks. Replace any damaged parts to prevent failure or equipment breakdown.

Visual Inspection Schedule and Recommended Procedure

A schedule for physical and visual inspections should be established by the operator based on severity of operation.

During each pre-trip and safety inspection of the vehicle, a visual inspection of the suspension should be done.

VISUALLY CHECK FOR:

- Bolt movement - loose dirt, rust or metal wear around bolt head and nut.
- Air Springs - wear damage and proper inflation.
- Shock absorbers - leaking or damaged.
- Cracked parts or welds.

TORQUE CHART

Size/Item	Torque in Ft. Lbs.	in Nm
1/2" Air Spring Nuts Top & Bottom	30-35	41-48
7/8" Pivot Conn. Nut	310-330	421-448
3/4" Shock Absorber Upper & Lower	90-110	122-149
3/4" Axle Adapter Nut	260-280	353-380
7/8" Track Bar Nut	310-330	421-448
1 1/8" Axle Bracket Connection	600-650	814-882
1 1/4" Transverse Beam	500-550	678-746

NOTE:

Torque specifications are with clean threads lubricated with oil.

IMPORTANT:

Torque specs do not include threads lubricated with anti-seize.

PRE-OPERATIONAL CHECKLIST

Prior to placing unit in service, check the following items:

Build air pressure above 70 P.S.I.G. (4.8 Bar). With vehicle shut off, check system for air leaks.

Check all frame fasteners per vehicle manufacturers recommended torque.

7/8" Pivot Nut torque to 310-330 ft. lbs. (421-448 Nm).

3/4" Axle Adapter Nut torqued to 260-280 ft. lbs. (353-380 Nm) or 7/8" nut torqued to 310-330 ft. lbs. (421-448 Nm) depending on axle size.

Some frame brackets have vertical bolts. Check and make sure they are installed, and properly torqued.

7/8" Track Bar Nut. Torque to 310-330 ft. lbs. or (421-448 Nm).

Minimum clearance around air springs is 1 3/4" (44mm).

Pinion angle should be within manufacturing specifications.

Suspension ride height should be within $\pm 1/4"$ of recommended design height. See Height Control Valve adjustment for proper setting, page 7.

1 1/8" Axle Bracket Connection Nut torque to 600-650 ft. lbs. (814-882 Nm).

3/4" Shock Absorber nuts. Torque to 90-110 ft. lbs. (122-149 Nm).

With vehicle on level surface, air supply pressure in excess of 70 P.S.I.G. (4.8 Bar), both Air Springs should be of equal firmness.

1/2" Air Spring Mounting Nuts (Top/Bottom). Torque to 30-35 ft. lbs. (41-48 Nm).

Transverse Beam Connection (1 1/4") Nut must be torqued to 500-550 ft. lbs. (678-746 Nm).

Check for proper installation of spacer washers at Transverse Beam and Equalizing Beam Connection.

Check Shock Absorbers for proper installation.

NOTE: Torque specifications are with clean threads lubricated with oil.

IMPORTANT: Torque specs do not include threads lubricated with anti-seize.

AD-160/200 PARTS LIST

NOTE: For Part Name Reference Only. Some parts may be in different orientation based on application (rear engine or front engine). See your specific Installation Dwg. for current locations/orientations.

NOTE: Shims not necessary with adjustable rod.

ADJUSTABLE PANHARD ROD
(TRACK BAR)
Min. 21.5"/Max. 23.5" Length

IMPORTANT: It is the responsibility of the suspension installer to determine and supply adequate frame reinforcement at the track bar attachment bracket.

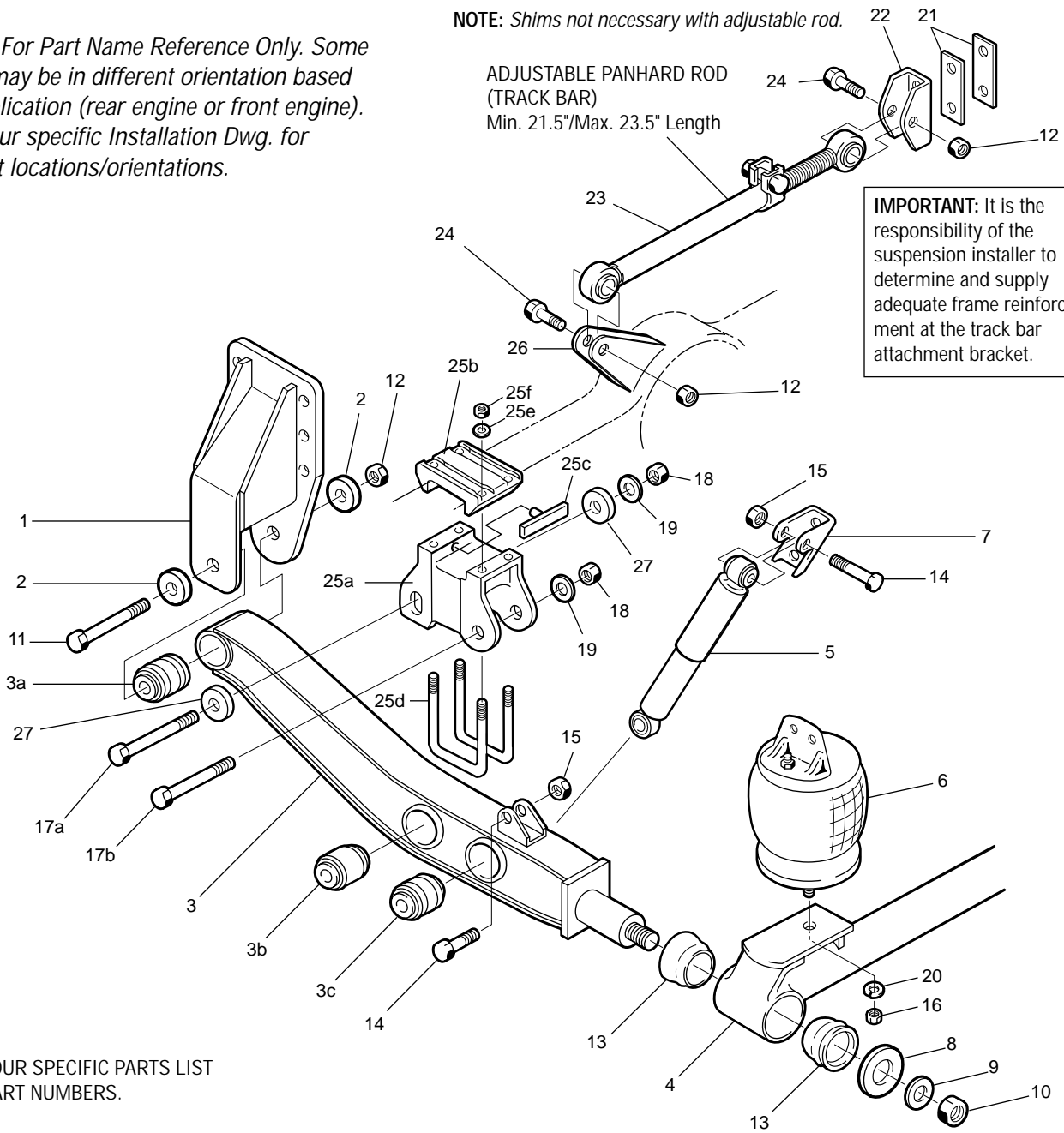

NOTE:
SEE YOUR SPECIFIC PARTS LIST
FOR PART NUMBERS.

Item No.	Description	Qty.	Item No.	Description	Qty.
1	Frame bracket	2	16	Hex Nut 1/2-13	2
2	Alignment Bushing	4	17a	Hex Bolt 1 1/8-7 x 7	2
3	Equalizing Beam Assembly	2	17b	Hex Bolt 1 1/8-7 x 8	2
3a	Bushing (Front End)	2	18	Hex Nut 1 1/8-7	4
3b	Bushing (Center)	2	19	Flat Narrow Washer 1 1/8	4
3c	Bushing (Rear End)	2	20	Lock Washer 1/2	2
4	Transverse Beam Assembly	1	21	Track Bar Shim	2
5	Shock	2	22	Control Arm Bracket (Frame)	1
6	Air Spring	2	23	Adjustable Panhard Torque Rod (Track Bar)	1
7	Shock Upper Bracket	2	24	Hex Bolt 7/8-9 x 4 1/2	2
8	Spacer Washer	2	25	DDK - Axle Adapter Kit	1
9	Flat Washer	2	25a	Axle Adapter	2
10	Hex Lock Nut 1 1/4-12	2	25b	Axle Cap	2
11	Hex Bolt 7/8-9 x 7 1/2	2	25c	Shim	2
12	Hex Lock Nut 7/8-9	4	25d	U-bolt	4
13	Bushing	4	25e	Washer	8
14	Hex Bolt 3/4-10 x 3 3/4	4	25f	Nut	8
15	Hex Nut 3/4-10	4	26	Track Bar Axle Bracket	1
			27	Alignment Bushing	4

Refer to page 13 for Frame Bracket Replacement instructions.

TYPE CR SINGLE HEIGHT CONTROL VALVE ADJUSTMENT

Adjustment Procedure

1. Prior to adjustment, the vehicle must be in an unladen condition and on a level floor.
2. Pressurize the air system with a constant supply of air in excess of 70 P.S.I.G. All air springs should inflate and be a proper ride height.
3. If ride height is off, adjust ride height by the adjusting nut (see Figure 1). Loosen the 1/4" nut, push up to increase ride height and pull down to decrease ride height.

NOTE: Valve has a built in time delay feature; therefore, several seconds may elapse prior to air flow.

4. Inspect air system and eliminate any air leaks.

NOTE: If proper ride height is not obtained or air springs do not inflate properly, check air pressure, check for proper piping and check CR valve as shown on page 8 Figure 3, Valve Inspection Procedure. Then if not functioning properly, contact the Neway Service Department

Figure 1

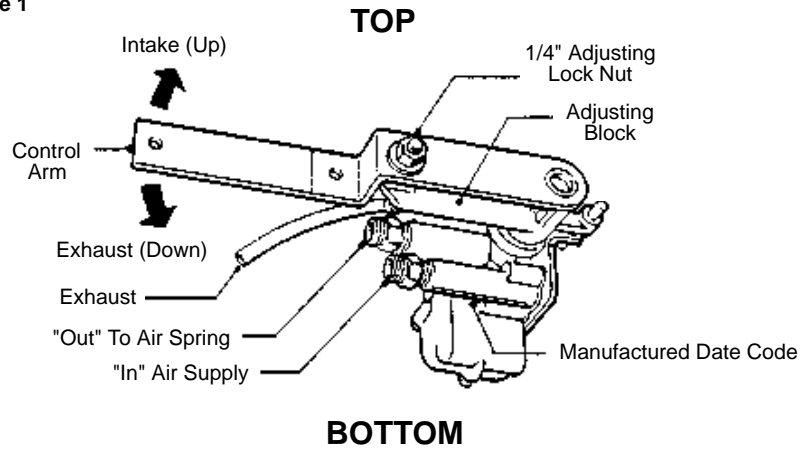
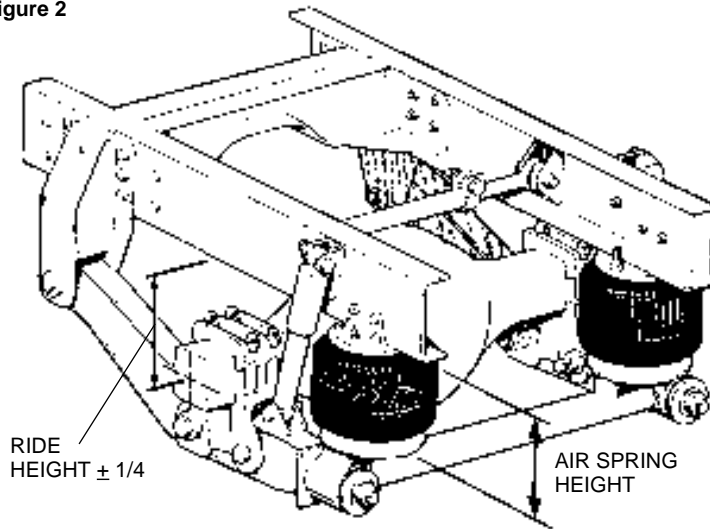

Figure 2



Ride Height vs Air Spring Height Chart

Model No.	Ride Height	Air Spring Height
AD-160-7	7.25"/7.5" (184/191mm)	10.5" (267mm)
AD-200-7	7.0"/7.5" (178/191mm)	10.5" (267mm)
AD-200-8	8.0"/8.5" (203/216mm)	11.5" (292mm)
AD-200-9	9.0"/9.5" (229/241mm)	11.5" (292mm)
AD-200-11	10.75/11" (273/279mm)	14.0" (356mm)

TYPE CR HEIGHT CONTROL VALVE INSPECTION

Inspection Procedure

Proper inspection can eliminate unnecessary replacement of height control valve.

1. Apply air Pressure in excess of 70 P.S.I.G. (4.8 Bar)*
2. Disconnect the link.
3. Move control arm up 45° for ten seconds (See Figure 3) - air pressure should inflate the air spring(s).
4. If the air spring(s) are not being inflated recheck the air lines for proper port connection and the control arm for proper position.
5. Move control arm to neutral position - valve should shut off air flow.
6. Move control arm down 45° for ten seconds - air should exhaust from the air spring(s) through the exhaust port of the CR-HCV.
7. Move control arm to neutral position - valve should shut off air flow.
8. Valve is good if performance is as noted.
9. If necessary, refer to adjustment procedure - page 7.

Figure 3

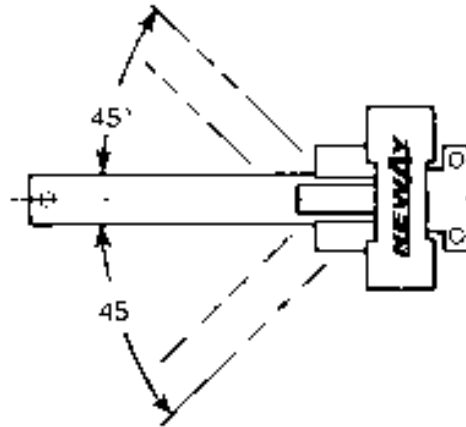

*If 70 P.S.I.G. (4.8 Bar) air system pressure cannot be achieved, check Pressure Protection Valve and vehicle Air Compressor to see if they are operating properly. Also check the air lines for obstructions caused by dirt particles, foreign debris, ice, etc.

Height Control Valve Care and Maintenance

1. Visually inspect the valve on a regular basis for proper clearance around or damage to valve control arm or adjusting block.
2. Dirt or foreign particles in the air line may harm the internal workings of the valve. Even though it contains a protective filter to eliminate foreign matter, normal air brake system maintenance should be practiced – DO NOT grease valve.
3. Drain moisture from air tank periodically. In severe cold weather an air dryer and/or alcohol evaporator is recommended to avoid valve freezing and damage.

PARTS LIST — AIR CONTROLS

AC-3600-CR

AIR PRESSURE PROTECTION VALVE & FILTER MAINTAINS SAFE AIR BRAKE PRESSURE AND CLEANS AIR. SET TO 70 P.S.I.G. (4.8 Bar) AT FACTORY

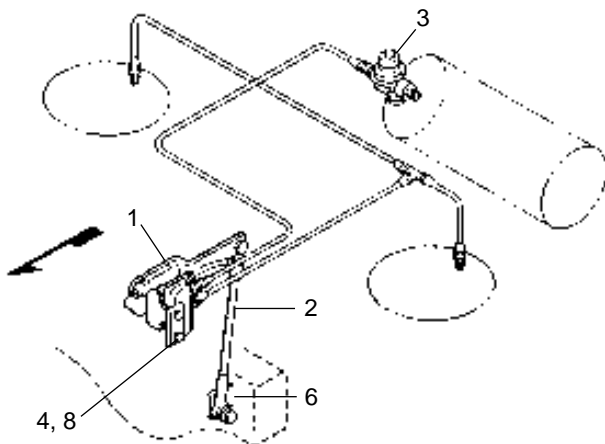

Item	Part No.	Description	Qty.
1	900 54 007	Height Control Valve	1
2	481 00 225	Flexible Link Assembly - SRK 168	1
3	905 54 107	Air Pressure Protection Valve & Filter	1
4	934 00 060	1/4 - 20 Hex. Lock Nut (Gr. B)	4
5	941 00 119	Decal (Operating) (Not Shown)	1
6	900 31 425	Axle Bracket	2
7	900 18 090	Mounting Bracket (Not Shown)	2
8	930 02 349	1/4 - 20 x 3/4 Hex. Hd. Cap Screw (Gr. 4)	4
9	941 00 466	Height Control Valve Instructions	1

FLEXIBLE LINK ASSEMBLY (Type CR HCV)

Assembly Procedure

1. Determine length of Link Assembly required ("A" Dim.). (See Figure 4)
This can be done by measuring the Link removed or the distance from centerline of Height Control Valve Arm hole to centerline of lower connection bracket hole.

NOTE: This measurement must be taken with suspension at proper ride height.

2. Determine length of Rod required ("B" Dim.) by subtracting 1 3/4" (44mm) from "A" Dim. Example: 13 3/4" (349 mm) "A" Dim. minus 1 3/4" (44mm) = 12" (305mm) "B" Dim., the length of the Rod required.
3. Cut Rod to length required; remove any sharp edges that may cause damage to the Rubber Link Ends during assembly.
4. Assemble Clamps, Link ends and Rods as shown.(See Figure 4)
Insert Rod into Link End equal distance both ends, **observing the minimum and maximum tolerance.** Be certain the Link Ends are parallel to each other.

5. With Link Ends properly aligned and Link Assembly at required length, tighten Clamps.
6. Install Link Assembly.
NOTE: 1/4" washers to be inserted between nut and control arm or bracket, 5/16" washer between bolt head and rubber link. Torque to 24 - 48 lb. in. (See Figure 4)

Service Repair Kit SRK-168

Item	Part No.	Description	Qty.
*1	900 06 396	Rod 18 1/4" long (SRK-168)	1
2	900 54 516	Link End	2
3	939 00 198	Hose Clamp	2
4	939 00 224	Shoulder Bolt	2
5	939 00 119	Washer 1/4" Plain	2
6	934 00 060	Lock Nut 1/4" - 20	2
7	936 00 118	Washer 5/16"	2

*NOTE: Item 1 - P/N 900 06 396 (SRK-168) is for use when servicing Link Assemblies with required lengths from 4.5 inches (114 mm) to 20 inches (508 mm).

Figure 4

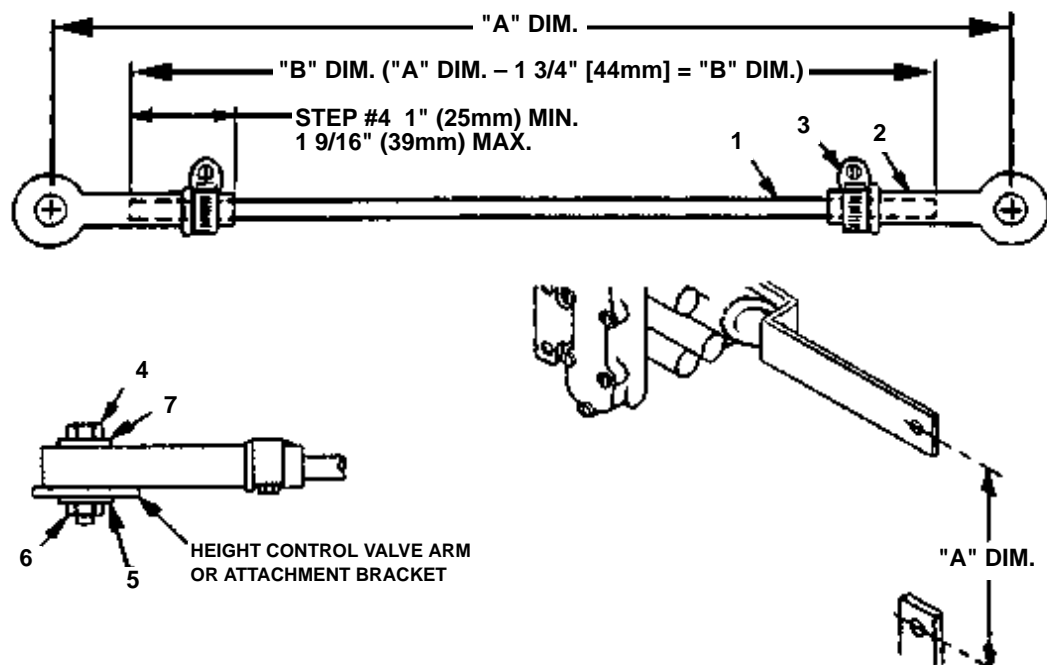

TYPE IR SINGLE HEIGHT CONTROL VALVE ADJUSTMENT

Adjustment Procedure

1. Prior to adjustment, the vehicle must be in an unladen condition and a level floor.
2. Pressurize the air system with a constant supply of air in excess of 80 P.S.I.G. (5.5 Bar) All air springs should inflate and be a proper ride height.
3. If ride height is off, adjust height control valve by loosening the hose clamp (as shown Figure 5) on the universal connection fitting. Push up to raise ride height and push down to lower ride height (Retighten hose clamp after adjustment).
4. Inspect air system and eliminate any air leaks.

Figure 5

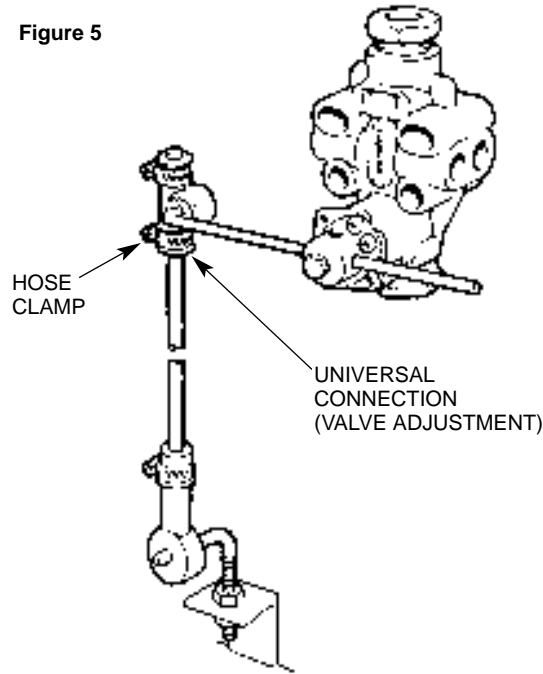

NOTE: If proper ride height is not obtained or air springs do not inflate properly, check air pressure, check for proper piping and repeat above steps. Then if not functioning properly, contact the Neway Service Department.

NOTE: A Neway Type IR-HCV can be installed in a vertical or horizontal position with the control arm in either left-hand or right-hand position. Refer to Form SD-922 or contact Neway Service Dept. for information.

Figure 6

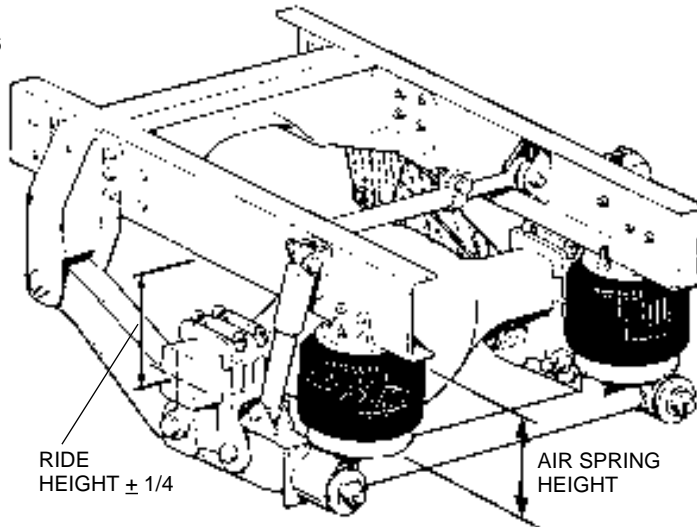

Ride Height vs Air Spring Height Chart

Model No.	Ride Height	Air Spring Height
AD-160-7	7.25"/7.5" (184/191mm)	10.5" (267mm)
AD-200-7	7.0"/7.5" (178/191mm)	10.5" (267mm)
AD-200-8	8.0"/8.5" (203/216mm)	11.5" (292mm)
AD-200-9	9.0"/9.5" (229/241mm)	11.5" (292mm)
AD-200-11	10.75/11" (273/279mm)	14.0" (356mm)

TYPE IR HEIGHT CONTROL VALVE INSPECTION PROCEDURE

Inspection Procedure

Proper inspection can eliminate unnecessary replacement of height control valve.

1. Apply air Pressure in excess of 70 P.S.I.G. (4.8 Bar)*
2. Loosen hose clamp and disconnect the universal link.
3. Move control arm up 20° (above horizontal) - air pressure should inflate the air spring. (See Figure 7)
4. If the air spring(s) are not being inflated recheck the air lines for proper port connection and the control arm and actuation shaft for proper position.
4. Move control arm to neutral position - valve should shut off air flow.
5. Move control arm down 20° - air should exhaust from the air spring(s) through the exhaust port of the IR-HCV.
6. Move control arm to neutral position - valve should shut off air flow.
7. Valve is good if functioning as noted.
8. If necessary, refer to adjustment procedure - page 10.

Figure 7

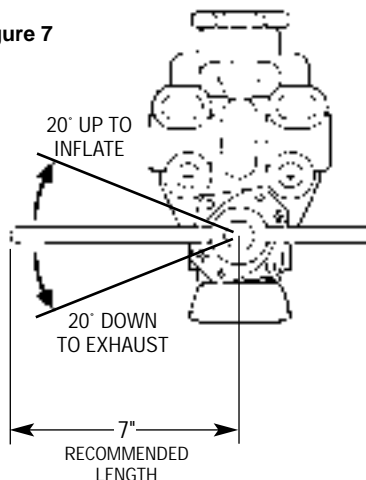

*If 70 P.S.I.G. (4.8 Bar) system pressure cannot be achieved, check Pressure Protection Valve and vehicle Air Compressor to see if they are operating properly. Also check the air lines for obstructions caused by dirt particles, foreign debris, ice, etc.

Height Control Valve Care and Maintenance

1. Visually inspect the valve on a regular basis for proper clearance around or damage to valve control arm.
2. Dirt or foreign particles in the air line may harm the internal workings of the valve. Normal air brake system maintenance should be practiced – DO NOT grease valve.
3. Drain moisture from air tank periodically. In severe cold weather an air dryer and/or alcohol evaporator is recommended to avoid valve freezing and damage.

NOTE: The Type IR Height Control Valve has filter screens in the supply port and both air spring pots. To prevent air flow restrictions, the filters should be cleaned every six months or when air flow becomes restricted.

PARTS LIST — AIR CONTROLS TYPE IR-SINGLE HEIGHT CONTROL VALVE

AC-3600-IR

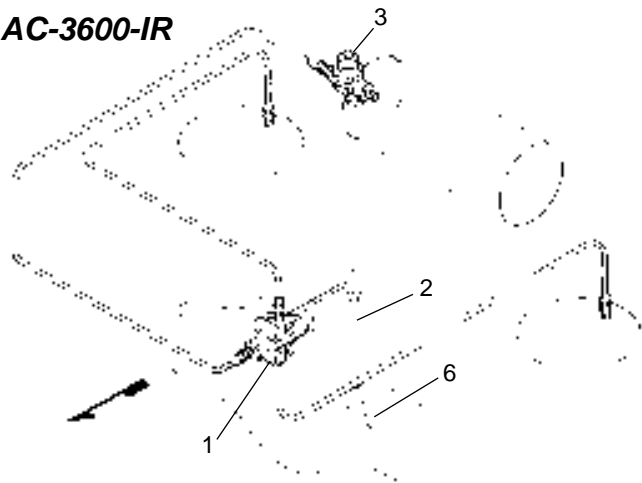

Item	Part No.	Description	Qty.
1	905 52 241	IR Height Control Valve	1
2	481 00 267	SRK-205 Link Assembly	1
3	905 54 107	Air Pressure Protection Valve & Filter	1
6	900 23 121	Axle Bracket	1
7	900 18 541	Mounting Bracket (Not Shown)	1

NOTE: A Newway Type IR-HCV can be installed in a vertical or horizontal position with the control arm in either left-hand or right-hand position. Refer to SD-922 or contact Newway Service Dept. for information.

FLEXIBLE LINK ASSEMBLY (Type IR HCV)

Assembly Procedure

1. Determine length of Rod required.

NOTE: Link assembly must be done with suspension at proper ride height.

2. Cut off excess Rod if required; remove any sharp edges that may cause damage to the Rubber Link Ends during assembly.

3. Assemble Clamps, Link Ends and Rod as shown.

NOTE: Control arm should extend 7" from center of lock bolt to universal link. See Fig. 8A

4. With Link Ends properly aligned and Link Assembly at required length, tighten Clamps.

NOTE: 1/4" washers to be inserted between cotter pins and universal link (one on each side).

NOTE: A Neway Type IR-HCV can be installed in a vertical or horizontal position with the control arm in either left-hand or right-hand position. Refer to form SD-922 or contact Neway Service Dept. for information.

Service Repair Kit SRK-205

Item	Part No.	Description	Qty.
*1	900 54 634	Rod 18" long	1
2	900 54 670	Link End (Bottom Connector)	1
3	900 54 630	Link End (Universal Connector)	1
4	900 54 636	Lower Link Connector	1
5	939 00 198	Hose Clamp	3
6	938 00 070	Cotter Pin	2
7	900 54 635	Control Arm	1
8	936 00 522	Flat Washer	2
9	934 00 468	Lock Nut	1
10	934 00 124	Nut	1

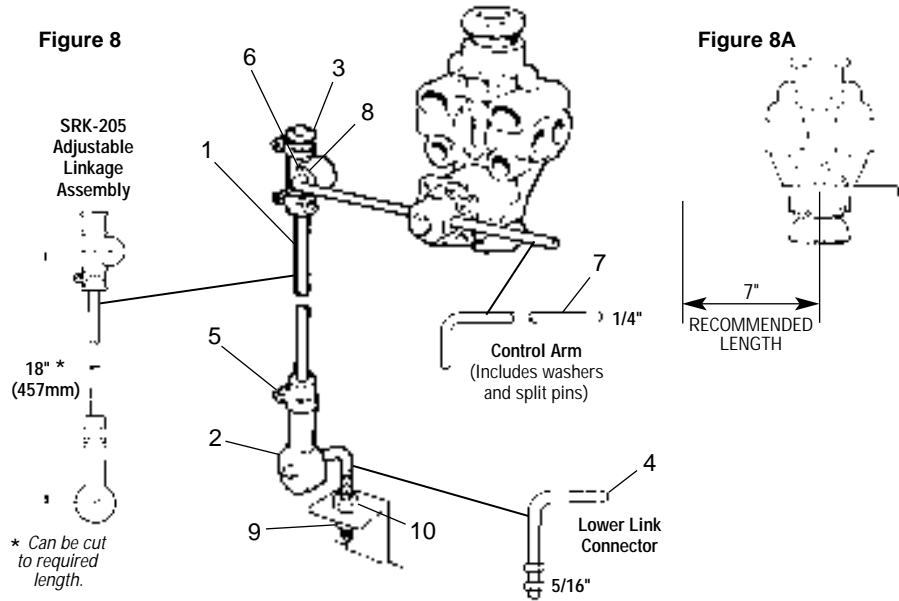

PRESSURE PROTECTION VALVE & FILTER

Periodic Maintenance

Drain all moisture from air reservoir at regular intervals. Approximately every 3 months, remove air filter and "O" ring from bottom of valve and inspect. (See Figure 9) replace if necessary (SRK-143). Replace "O" ring and air filter, **hand tighten only.**

The PPV must be checked for proper operation during each brake system inspection. The purpose of the valve is to maintain at least 70 P.S.I.G. (4.8 Bar) brake operating pressure in event of a serious air leak in the suspension system. With the air tank pressure charged above 75 P.S.I.G. (5.2 Bar), disconnect air line from downstream (suspension) side of PPV. Air should stop flowing through the valve before the spring brakes begin to apply or before 70 P.S.I.G. (4.8 Bar) tank pressure is reached. If air does not stop flowing, replace the valve.

Figure 9

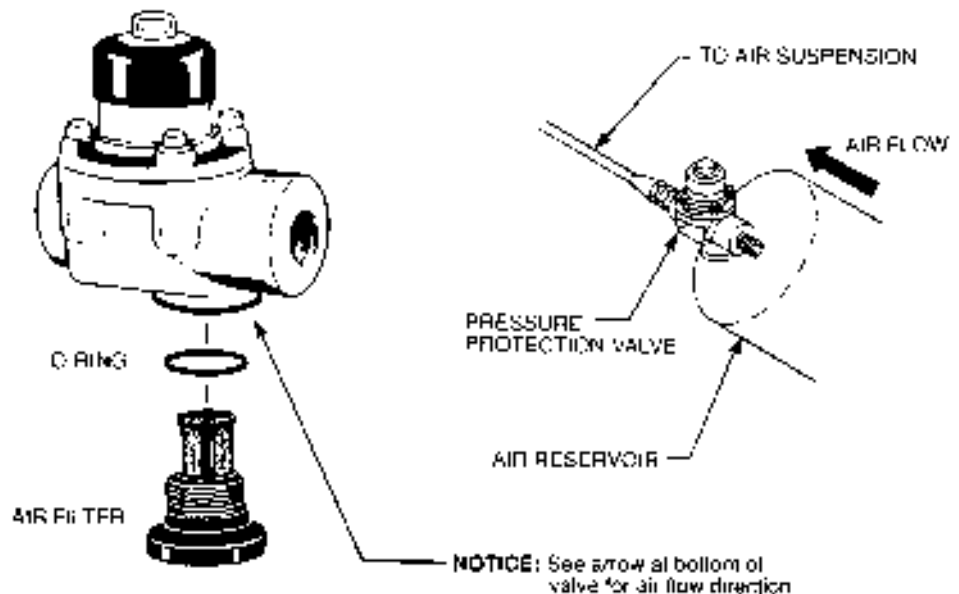

SERVICE REPAIR KITS

When servicing your Neway Air Ride Drive Axle Suspension use the convenient service repair kits noted below.

Model	Pivot Connection	Axle Pivot Connection	Transverse Connection
AD-160/200	SRK-242	SRK-244	SRK-245

NOTE: One (1) SRK Required per axle.

Figure 10

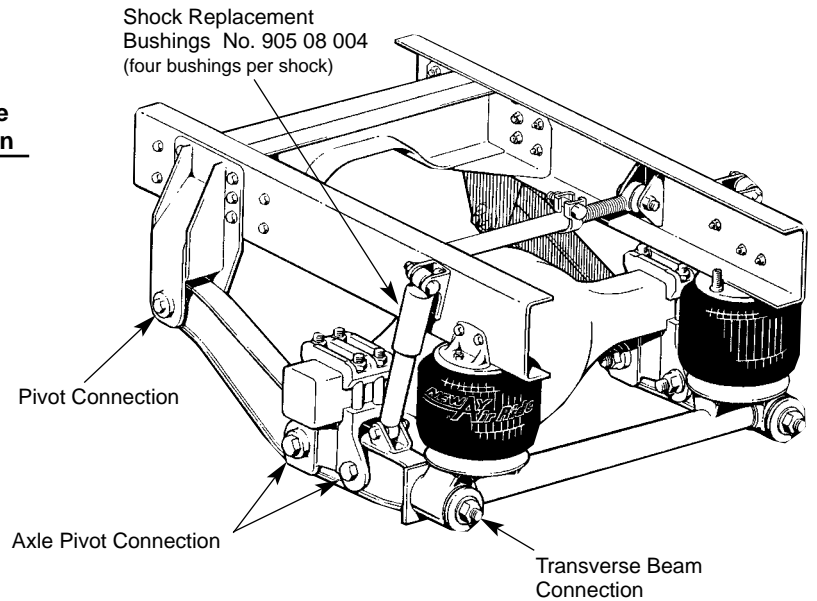

REPLACEMENT INSTRUCTION — FRAME BRACKET

Frame Bracket Installation

1. Support frame, then exhaust air from air springs.
2. Disconnect frame bracket and remove. Make note of alignment block positions for reassembly.
3. Replace pivot rubber bushing if necessary.
4. Reassemble pivot connection hardware and position alignment blocks as previously noted in Step 2. **DO NOT WELD ALIGNMENT BLOCKS AT THIS TIME.**
5. With suspension set at proper Ride Height, (see page 5) align axle by shifting alignment blocks (fore/aft). Torque the pivot connection nut to 310-330 ft. lbs. (421-448 Nm) lubricated. (See Torque Note)
6. Recheck alignment, then weld alignment blocks on both sides of each frame bracket. (See Figure 11) Make three 3/4" welds using welding rod E-7028 or equivalent.
7. **AFTER ALIGNMENT** blocks are welded and have cooled down retorque the pivot connection to 310-330 ft. lbs. (421-448 Nm) lubricated.

Figure 11

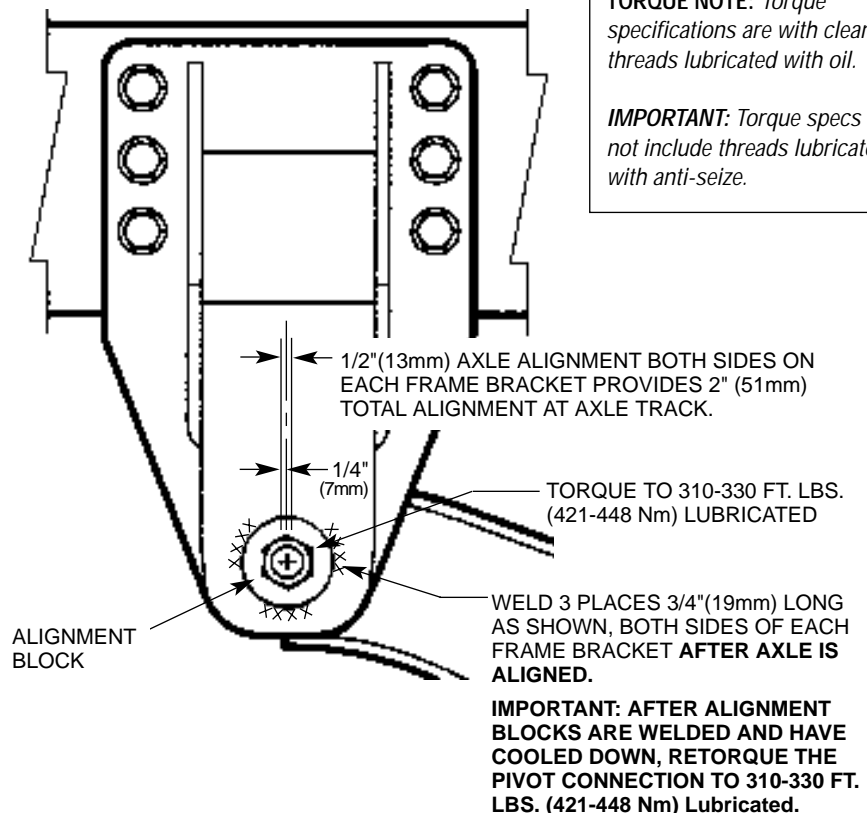

Shock Absorbers

1. It is recommended the vehicle be unloaded. Block vehicle to prevent rolling.
2. Remove upper and lower mounting bolts and shock absorber.
3. Replace with correct shock absorber.
4. See Torque Chart page 4.

Bushings - Equalizing Beam

The rubber bushings in the equalizing beam may be replaced using a hydraulic press with a capacity of 10,000 lbs. or greater.

To replace the bushings in an equalizing beam, first remove the beam from the vehicle. The following procedure is recommended:

1. It is recommended the vehicle be unloaded. Block vehicle to prevent rolling. Support vehicle frame with adequate jacks or stands. Remove tires
2. Exhaust air by:
 - A. Automatic control - height control valve - disconnect link at lower connection, then rotate control arm down to exhaust (approx. 45° down for Type CR HCV), (approx. 20° down for Type IR HCV). Drain all air from air reservoir.
 - B. Disconnect air supply line from air spring.
3. Disconnect shock absorbers, and air springs at lower end.
4. Disconnect transverse beam (if it does not come off easily, use a port-a-power between the axle and transverse beam) Do not damage the axle or transverse beam.
5. Support the beam. Press out old bushings with a hydraulic press
CAUTION: The Beam support fixture must be securely mounted to the hydraulic press.
6. Clean out bushing receptacles in beam of all foreign material before pressing in new bushings.
7. Lubricate the new replacement bushing and tube receptacle with an approved rubber lubricant or a soap and water solution.
NOTE: DO NOT USE AN OIL-BASED LUBRICATION OR BRAKE FLUID, as it can cause damage to the rubber. With the beam supported press the new bushing into the beam. (Refer to Step No. 9)
8. Inspect all parts for wear, cracks or failed welds - repair or replace if necessary.
CAUTION: DO NOT REPAIR A CRACKED EQUALIZING BEAM - REPLACE IT.

Figure 12

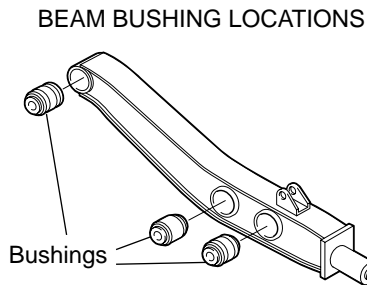

9. **NOTE:** Bushings are to be centered in the equalizing beam. (See Figure 13)

Figure 13

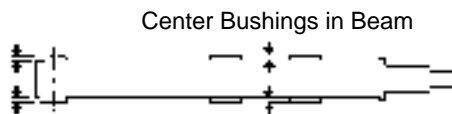

10. Reassemble new or rebushed equalizing beam to frame bracket.
11. Reassemble axle and transverse beam connections. **NOTE: BEFORE TORQUING FRONT PIVOT BOLT, SET SUSPENSION AT PROPER RIDE HEIGHT.**
12. Reconnect air springs, shock absorbers, and height control valve link (Torque to proper specifications).
13. Re-install wheels and tires. Remove jacks and or stands, and build air reservoir pressure in excess of 70 P.S.I.G (4.8 Bar). Check for proper ride height, page 7. **CAUTION: 100 P.S.I.G. (6.9 Bar) IS MAXIMUM ALLOWABLE OPERATING AIR SYSTEM PRESSURE.**

Bushings Transverse Beam

1. **NOTE: REFER TO AND PERFORM PROCEDURE 1 AND 2 OF EQUALIZING BEAM BUSHING REPLACEMENT. PRIOR TO PROCEEDING (DO NOT REMOVE TIRES).**
2. Disconnect air springs at the lower connection.
3. Remove transverse beam.
4. Remove the bushings.
5. Clean out bushing receptacles in beam of all foreign material before assembling new bushings into the beam.
IMPORTANT: Inspect all parts for wear, cracks or failed welds - repair or replace. **CAUTION: DO NOT REPAIR A CRACKED TRANSVERSE BEAM - REPLACE IT.**
6. Reassemble new or rebushed transverse beam on equalizing beam with new bushings as shown. (See Figure 14)

Figure 14

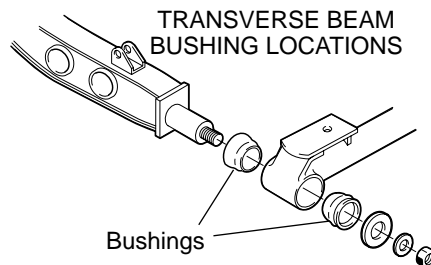

7. Reconnect air springs.
8. Remove jacks and or stands, and build air reservoir pressure in excess of 70 P.S.I.G. (4.8 Bar) Check for proper ride height.
CAUTION: 100 P.S.I.G. (6.9 Bar) IS MAXIMUM ALLOWABLE OPERATING AIR SYSTEM PRESSURE.

Suspension Air Springs

1. **CAUTION:** Be sure to use proper air spring replacement.
2. **CAUTION:** Prior to removing air spring vehicle must be unloaded. Support vehicle frame with adequate jacks or stands at approximate ride height.
3. Exhaust air from suspension system. Exhaust air by:
 - A. Automatic Control - Height control valve - disconnect link at lower connection, then rotate control arm down to exhaust (approx. 45° down for Type CR HCV), (approx. 20° down for Type IR HCV).
 - B. Disconnect air supply line from air spring.
4. Disconnect and remove old air spring assembly.
5. Install new air spring assembly and properly torque fasteners. See Torque Chart Page 4.
6. Reconnect air supply line and link connections.
7. Remove jacks and or stands.
8. Build air supply system to compressor cut-off pressure, check for leaks.
CAUTION: 100 P.S.I.G. (4.8 Bar) IS THE MAXIMUM ALLOWABLE OPERATING PRESSURE.

TROUBLE SHOOTING

Problem

All air Springs flat (no air).

Possible Cause and Remedy

Insufficient air pressure in the vehicle air system. Check the air pressure gauge on instrument panel. If air pressure is low, run the engine until a minimum pressure of 70 P.S.I.G. (4.8 Bar) is indicated on the gauge.

Air leakage from the suspension air system or the air brake system. Listen for air leakage due to loose fittings or damaged air lines, air springs, brake actuators or control valve. Tighten loose fittings to stop leakage and/or replace worn or damaged parts.

Air springs deflate rapidly when vehicle is parked.

Air leakage from the suspension air system. Listen for air leakage due to loose fittings between air tank and air suspension or damaged air lines, air springs or height control valve. Apply a soapy solution to connections and air springs if necessary to check for bubbles (leaks). Tighten loose fittings to stop leakage and/or replace worn or damaged parts with new ones.

Chassis ride height too high or too low.

Height control valve out of adjustment. Re-adjust the height control valve.

Air springs ruptured.

Air spring cut or punctured. Replace.

Air spring failed.

Continual or repeated over-extension of the air spring. Visually inspect for broken or loose shock absorber or shock absorber mounting bracket. Reconnect loose parts and replace any defective parts. Check the adjustment of the height control valves.

Air spring(s) worn out. Replace.

Air spring(s) fail to fully deflate when all weight is removed from the suspension.

Restricted air line(s) between the height control valve and the air spring(s). Disconnect the height control valve linkage and rotate the actuating lever to the 45° down position. If the air spring(s) remain inflated, check for pinched or blocked line(s).

Front pivot connection worn and loose.

Check with a pry bar to determine if pivot connection is loose, under torqued. Replace bushing - be sure suspension is set at proper ride height before torquing the pivot connection.

Worn out due to length of service. Replace pivot connection.

Shock absorber failures.

Over-extension. Mislocated shock brackets. Improper shocks installed. Check for oil leaking from shock. If worn out from length of service, replace.

Excessive tire wear.

Axles mis-aligned. Re-align axles per vehicle manufacturer's recommendations. Suspension has alignment blocks located on the frame bracket pivot connections for alignment. Alignment blocks are welded in position, weld must be removed prior to re-alignment. Reweld after alignment.
Worn pivot or axle bushings. Rebush with proper bushing.

Vehicle unstable or handles poorly.

Loose frame bolts or attachments. Tighten frame bolts and attaching parts to proper specifications.

Cracked or loose frame crossmembers. Repair or replace damaged frame members and torque all nuts and bolts to proper torque specifications.

Check the ride height, Readjust if necessary.

Loose transverse beam connection. Replace worn bushings, retorque to specifications.

Loose or worn pivot connection. Retorque to specification and/or rebush if necessary.

Contact your vehicle manufacturer for his recommendation if these possible causes and effects do not solve the vehicle handling problem.

***Additional copies of this
Maintenance Manual
are available from
Neway Distributors
or by writing directly to:***



MAKING THE WORLD'S ROADWAYS SAFER & SMOOTHER

U.S.A.
1950 INDUSTRIAL BLVD.
P.O. BOX 425
MUSKEGON, MI
49443-0425 U.S.A.
TEL: (616) 773-3271
FAX: (616) 766-3893

CANADA
1153 LORIMAR DR.
MISSISSAUGA,
ONTARIO
CANADA L5S 1M5
TEL: (905) 670-8858
FAX: (905) 670-4382

EUROPE
UNITS 250-251 IKON TRADING ESTATE
DROITWICH ROAD
HARTLEBURY, WORCESTERSHIRE
DY10 4ED UNITED KINGDOM
TEL: 44-(0)-1299-251663
FAX: 44-(0)-1299-251664

AUSTRALIA
SALES/DISTRIBUTION
DANA AUSTRALIA PTY. LTD.
39-45 WEDGEWOOD ROAD
HALLAM, VICTORIA
3803 AUSTRALIA
TEL: 61-(0)-9213-5555
FAX: 61-(0)-9213-5580