

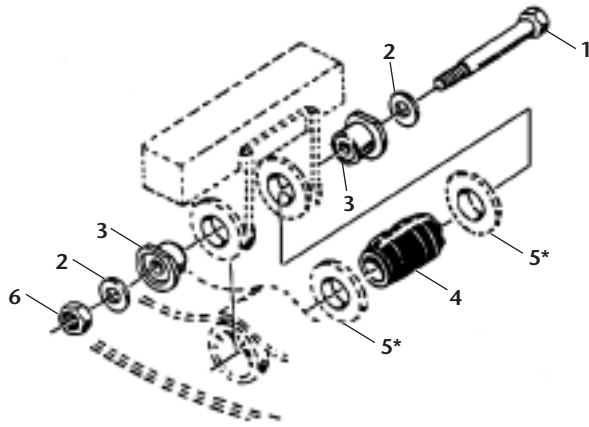

GO THE DISTANCE.

AD/ARD SERVICE REPAIR KIT SERIES



NOTE: AD-123/246 or other suspensions where washers are present. Some products do not require washers (item 5).

TRUCK/TRACTOR SUSPENSION MODELS

Truck: ARD-125/244-6, ARD-125/244-8, ARD-234-6, ARD-238-6, ARD-120-6, AD-123/246/369

DISASSEMBLE AXLE BEAM HANGER CONNECTION

Step 1Block vehicle front wheels to prevent rolling. Raise vehicle 2", supporting frame with jacks or stands downward.

Step 2Exhaust all air from air springs both sides of vehicle by disconnecting height control valve links at lower end, and then rotate height control valve arm to exhaust position (down 45° approx.). Disconnect air supply line from air springs. Remove tires.

CAUTION Be sure air is completely exhausted.

Step 3Loosen and remove pivot bolt. Note position of spacer washers at front pivot connections for reassembly. Position jacks under equalizing beam for ease of lowering. Disconnect air springs and shock absorbers at lower end, remove transverse beam, and then remove equalizing beam. Note the presence or absence of spacer washers (item 5).

SRK-80 BUSHING CONNECTION

For applicable models, see left column. Kit is used when servicing 5-1/4" axle beam hanger bushing connection.

SRK-80: 481 00 124

Pivot Connection - 1 kit per axle

Item	Part No.	Description	Qty.
1	930 03 693	Hex Hd Cap Screw 3/4"-10x7-1/2"	2
2	936 00 156	Washer 3/4"	4
3	900 01 002	Adapter Bushing	4
4	900 08 008	Rubber Bushing 5-3/4" Long	2
5	900 01 065	Spacer Washer 4.25"x3.03"x0.31"	4
6	934 00 492	Lock Nut 3/4" - 10	2

NOTE: New bushings recommended when bushing surface becomes deformed. Refer to parts list.

WARNING Never repair a cracked equalizing beam. If cracks are detected anywhere on a beam, replace the beam; otherwise, secondary weld failures during use may cause loss of vehicle control and could cause serious injury or death.

Step 4Press out old bushings, and clean out all foreign material from bushing tubes.

IMPORTANT: DO NOT use an open flame or other heat source to remove the bushings.

Step 5Lubricate new bushings with approved rubber lubricant such as P-80 or equivalent.

IMPORTANT: DO NOT use an oil-based lubricant, soap and water solution, or brake fluid as they can cause damage to the rubber.

Step 6Install new bushings using Bushing Service Tool, Part No. 505 44 001, to ease removal and replacement of bushings, reducing installation time. Contact your Holland distributor for details. Press bushing past center, and turn beam over to center in beam.

*REASSEMBLE THE AXLE BEAM HANGER CONNECTION

Step 1Before installing beam, inspect frame brackets for any excessive wear such as elongated holes, cracks or cracked welds.

⚠ WARNING Never repair a cracked frame bracket. If cracks are detected anywhere on a bracket, replace the bracket; otherwise, secondary weld failures during use may cause loss of vehicle control and could cause serious injury or death.

Step 2Install beam at ride height, reinstalling hardware as noted during disassembly, and tighten front pivot to proper torque (1-1/4" to 700 ft. lbs., 1-1/8" to 600 ft. lbs. lubricated).

Tighten lock nut (item 6) to 200 ft. lbs. lubricated. Reinstall transverse beam (1-1/4" to 700 ft. lbs., 2-1/4" to 525 ft. lbs. lubricated), air spring (1/2" and 3/4" to 35 ft. lbs.), shock absorbers (3/4" to 150 ft. lbs.), and height control valve links (1/4" to 24-48 in. lbs. lubricated).

TORQUE CHART

SIZE	ITEM	TORQUE	
		IN FT. LBS. AD MODELS	NM
1/2"	Air Spring	30-35	40-47
1 1/8"	Pivot	600	813
1 1/4"	Pivot	700	949
3/4"	Shock Absorber	150	203
1 1/4"	Transverse Beam	700	949
2 1/4"	Transverse Beam	500-550	677-745

TORQUE NOTE:

Torque specifications are $\pm 5\%$ tolerance.

Reconnect air lines to air springs, and reinstall tires.

Step 3Remove jacks or stands. Pressurize air system in excess of 65 psig, and check for leaks.

NOTE: It is recommended that a pivot and transverse beam Service Repair Kit be installed at this time. Refer to Holland Neway Master Parts Catalog (XL-AM100-01) for proper kit numbers.

HOLLAND USA, INC.
1950 Industrial Blvd. • P.O. Box 425 • Muskegon, MI 49443-0425
Phone 888-396-6501 • Fax 800-356-3929
www.thehollandgroupinc.com

Copyright © September 2004 • The Holland Group, Inc.

Holland USA, Inc. Facilities:

Dumas, AR Warrenton, MO
Holland, MI Wylie, TX
Muskegon, MI

Ph: 888-396-6501 Fax: 800-356-3929

Holland International, Inc.

Holland, MI
Phone: 616-396-6501
Fax: 616-396-1511

Holland Hitch of Canada, Ltd.

Woodstock, Ontario • Canada
Phone: 519-537-3494
Fax: 800-565-7753

Holland Equipment, Ltd.

Norwich, Ontario • Canada
Phone: 519-863-3414
Fax: 519-863-2398

Holland Hitch of Canada, Ltd.

Surrey, British Columbia • Canada
Phone: 604-574-7491
Fax: 604-574-0244