

**IMPORTANT:** Different frame widths require various spacer washer placement at the pivot connection.

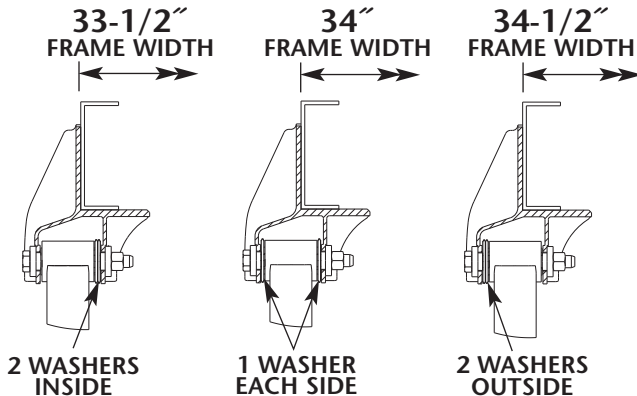

### Pivot Bolt Torque Lubrication Requirements -

Old Style (pre June 2002) vs.

New Style (post June 2002) Identification



Pivot Connection Bolt Head marked "NEWAY" **REQUIRES** lubrication.



Pivot Connection Bolt Head marked "HOLLAND NEWAY" **DOES NOT REQUIRE** lubrication.

Old Style (pre June 2002)  
Pivot Bolt with Phos & Oil Protectant Coating

New Style (post June 2002)  
Pivot Bolt with Permanent Protectant Coating



SRK-563 & SRK-565

AD SERIES PIVOT CONNECTION

SERVICE REPAIR KITS

**SRK-563: 481 00 427**

**Pivot Connection - AD-123 & AD-126 Models**

Item	Part No.	Description	Qty.
1	932 01 055	Rod Bolt 1-1/8" - 7 x 9-17/32"	2
2	934 00 506	Lock Nut 1-1/8" - 7	2
3	900 08 252	Rubber Bushing	2
4	936 00 502	Spacer Washer	4
5	936 00 174	Flat Washer, Narrow	4
6	XL-AK399-01	Decal, Torque Specification	1

**SRK-565: 481 00 429**

**Pivot Connection - AD-130 Models**

Item	Part No.	Description	Qty.
1	932 01 068	Rod Bolt 1-1/4" - 7 x 9.0"	2
2	934 00 510	Lock Nut 1-1/4" - 7	2
3	900 08 256	Rubber Bushing	2
4	936 00 546	Spacer Washer	4
5	XL-AK399-01	Decal, Torque Specification	1

**NOTE:** NEW ALIGNMENT BUSHINGS RECOMMENDED WHEN ALIGNMENT BUSHING SURFACE BECOMES DEFORMED. REFER TO PARTS LIST.

### WELDING SPECIFICATIONS

**WELDS** - weld the alignment block to the frame bracket with three (3) - 1" (26mm) welds equally spaced around the circumference of the alignment block. Allow the alignment block to cool for at least 3 minutes and then re-torque connection as specified in Torque Chart page 2.

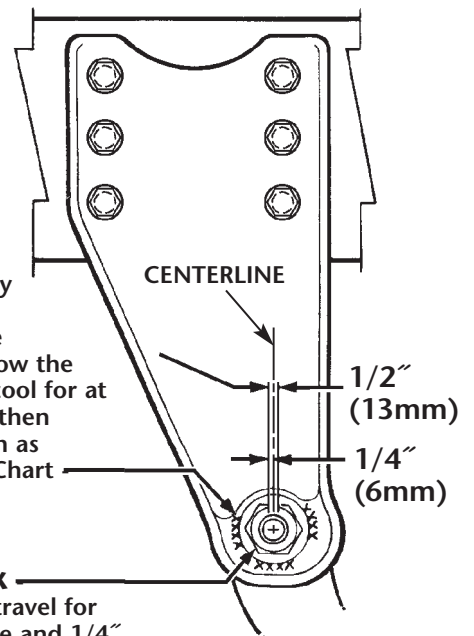

**ALIGNMENT BLOCK**  
1/2" (13mm) total travel for alignment (1/4" fore and 1/4" aft travel from alignment slot center line).

**Table 1**

**RECOMMENDED TORQUE SPECIFICATIONS FOR AD SERIES  
SUSPENSION PIVOT CONNECTIONS**

**GENERAL INFORMATION**

- **Torque specifications listed are applied to the nut.**
- **Torque specifications: +/- 5% tolerance**
- **Lubricated Vs. Non-Lubricated Threads** – The torque specifications stated are for lubricated and non-lubricated fasteners. Holland defines lubricated vs. non-lubricated as follows:
  - **Lubricated** – a bolted connection, such as the pivot bolt/nut arrangement, that has some form of friction modifier or lubricant pre-applied or applied to the thread surfaces, providing a lower torque requirement for a predetermined clampload.
  - **Non-Lubricated** – a bolted connection, either new or in service, that has little or no lubricant on the thread surfaces. Typically, this applies to bolted connections that have been in service for a certain length of time where the original protective coating has evaporated or deteriorated due to environmental exposure. Thus, a “non-lube” torque specification is commonly required for in-service torque check or retorquing procedures. A “non-lube” specification could be required for new installations if the pivot bolt has seen sufficient shelf life to allow for evaporation and deterioration of the protective coating.

**NOTE: Use of special lubricants with friction modifiers, such as Anti-Seize or Never-Seize, without written approval from Holland Engineering will void warranty and could lead to premature bolt failure or other component issues.**

**IMPORTANT:**

- **Prior to June of 2002**, all AD Series pivot bolts supplied by Holland were coated with an industry standard corrosion protectant commonly referred to as “phos & oil”. The black colored phos & oil protectant is susceptible to evaporation. Thus, the lubricating properties of the phos & oil coating varies significantly depending on the age of the coating. Holland recommends pivot bolts to be considered “non-lube” even though the phos & oil coating may still be present (Figure 3).
- **As of June 2002**, Holland will supply all AD Series pivot bolts with a new coating that effectively eliminates the non-lube vs. lubricated issue. This silver colored coating is specifically formulated to provide greatly enhanced corrosion protection and act as a permanent lubricant. No additional lubrication is required (Figure 3). Thus, the new coating will only require one torque setting (with the possible exception of severe duty applications): 600 ft. lbs. Additionally, the coating will provide a superior, more consistent clampload.
- **Retorque Procedure** – to re-torque a connection, Holland recommends that the nut be loosened a couple of turns and then torqued to the recommended specification.

**SUSPENSION MODELS:**

**AD-123/246/369 and AD-126/252/378  
1 1/8” - 7 Pivot Connection Bolt**

**OEM Installation** – 600 ft. lbs.\* for lubricated threads or 800 ft. lbs.\* for non-lubricated threads.

**Dealer Pre-Delivery Inspection** – 600 ft. lbs.\* for lubricated threads or 800 ft. lbs.\* for non-lubricated threads. Threads may be lubricated or non-lubricated depending on OEM installation procedures. Check with the Truck OEM to confirm lubricated or non-lubricated threads.

\*Torque Specification: ± 5% Tolerance

**SUSPENSION MODELS:**

**AD-130/260/390  
1 1/4” - 7 Pivot Connection Bolt**

**OEM Installation** – 700 ft. lbs.\* for lubricated threads or 900 ft. lbs.\* for non-lubricated threads.

**Dealer Pre-Delivery Inspection** – 700 ft. lbs.\* for lubricated threads or 900 ft. lbs.\* for non-lubricated threads. Threads may be lubricated or non-lubricated depending on OEM installation procedures. Check with the Truck OEM to confirm lubricated or non-lubricated threads.

HOLLAND USA, INC.  
1950 Industrial Blvd. • P.O. Box 425 • Muskegon, MI 49443-0425  
Phone 888-396-6501 • Fax 800-356-3929  
www.thehollandgroupinc.com

Copyright © February 2005 • The Holland Group, Inc.

**Holland USA, Inc. Facilities:**

Dumas, AR Muskegon, MI  
Holland, MI Warrenton, MO  
Monroe, NC Wylie, TX

Ph: 888-396-6501 Fax: 800-356-3929

**Holland International, Inc.**

Holland, MI  
Phone: 616-396-6501  
Fax: 616-396-1511

**Holland Hitch of Canada, Ltd.**

Woodstock, Ontario • Canada  
Phone: 519-537-3494  
Fax: 800-565-7753

**Holland Equipment, Ltd.**

Norwich, Ontario • Canada  
Phone: 519-863-3414  
Fax: 519-863-2398

**Holland Hitch Western, Ltd.**

Surrey, British Columbia • Canada  
Phone: 604-574-7491  
Fax: 604-574-0244