

Instructions

Suspension Bushing Service Tool

Part No. 50544015

CB/CBX Series Pivot Bushing Replacement Procedures

Introduction

These instructions provide the necessary information about the proper use and function of the SAF-HOLLAND Bushing Service Tool, 50544015 for the replacement of pivot bushings.

1. On a level surface, support the front of the trailer with either a kingpin stand, landing gear, or coupled to a tractor (**Figure 1**).
2. Raise the trailer frame approximately 2" (51 mm) above the suspension's specified ride height. Refer to suspension's maintenance manual for details.
3. Place multiple jack stands at the suspension's specified ride height under the vehicle frame at OEM specified locations, then lower the trailer onto the jack stands.

NOTE: It may be necessary to shim jack stands to achieve specified height.

⚠ WARNING Failure to properly support the suspension during maintenance could create a crush hazard which, if not avoided, could result in death or serious injury.

4. Disconnect Height Control Valve linkage at lower connection and pull HCV arm down to exhaust all air from suspension(s).
5. Set parking brakes, and chock the wheels.

⚠ WARNING Failure to exhaust the suspension air and chock the tires prior to beginning maintenance could allow vehicle movement which, if not avoided, could result in death or serious injury.

NOTE: Prior to disassembly, place a jack and/or jack stands underneath the lower flange of the equalizing beam.

⚠ WARNING Failure to properly support equalizing beams could create a crush hazard which, if not avoided, could result in component damage, death or serious injury.

6. Disconnect front pivot connection hardware on both road-side and curb-side and discard all old hardware (**Figure 2**).

Figure 1

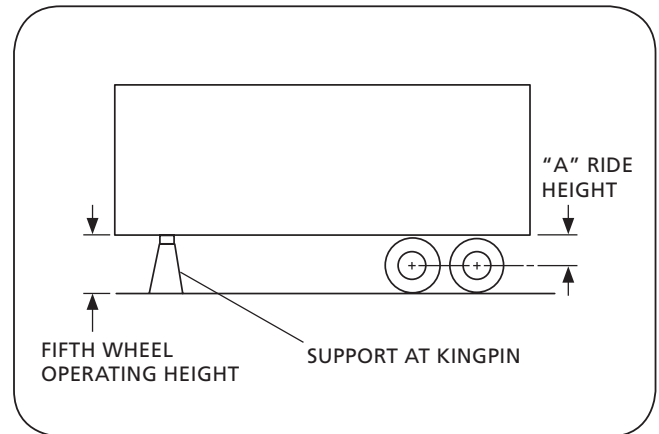
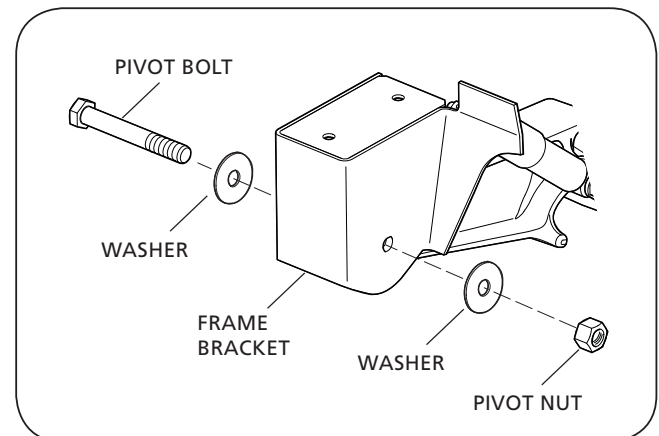

Figure 2



Bushing Replacement Instructions

- Rotate equalizing beams down. Make sure equalizing beams are supported by jack or jack stands.

⚠️ WARNING Failure to properly support equalizing beams could create a crush hazard which, if not avoided, could result in component damage, death or serious injury.

- Inspect equalizing beams for wear, cracks and failed welds at axle. If cracks are detected anywhere on an equalizing beam, replace the beam and axle assembly.

IMPORTANT: NEVER repair a cracked equalizing beam. DO NOT weld cracks. Secondary weld failures during use may cause loss of vehicle control.

⚠️ WARNING Failure to replace a cracked equalizing beam may cause loss of vehicle control which, if not avoided, could result in death or serious injury.

NOTE: Drive Adaptor Plate and Receiver Tube Bushing Adaptor must be used at all times (**Figure 3**). Bushing Adaptor is only used to guide new bushing tube on the beam, when removing bushing it is not required.

NOTE: Replacing bushings with the Bushing Tool requires the use of an air impact capable of producing a minimum torque of 200 ft.-lbs. (271 N•m) and a 1-13/16" heavy duty socket.

IMPORTANT: DO NOT use an open flame or other heat source to remove the bushings.

- Position steel sleeve on threaded rod and generously apply approximately 2" coat of silicone based lubrication compound such as "Sil-Glyde" onto threads (**Figure 4**).

IMPORTANT: Other lubricants will cause thread failures and ruin tool.

- Insert the threaded rod through the old bushing and thread into receiver tube assembly to remove old bushing (**Figure 5**).

NOTE: Receiver tube bushing adaptor must be used on receiver tube. Slots on the receiver tube bushing adaptor MUST align with the ribs of the equalizing beam to ensure proper fit to the equalizing beam.

- Using the proper wrench as indicated above apply torque to drive nut and force old bushing out of the equalizing beam receptacle (**Figure 5**).
- After bushing is removed disassemble the threaded rod from the bushing receiving tube.

Figure 3

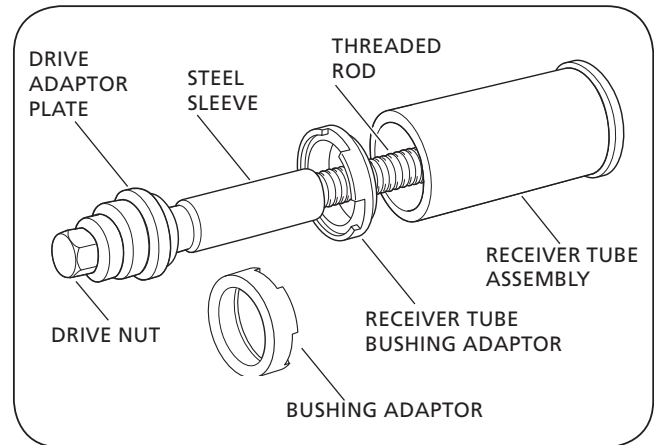

Figure 4

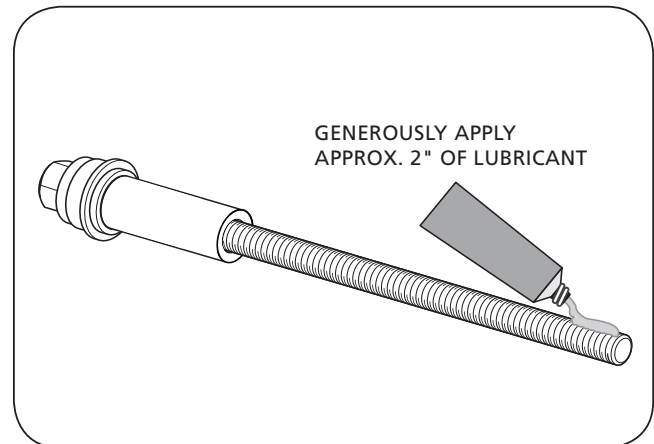
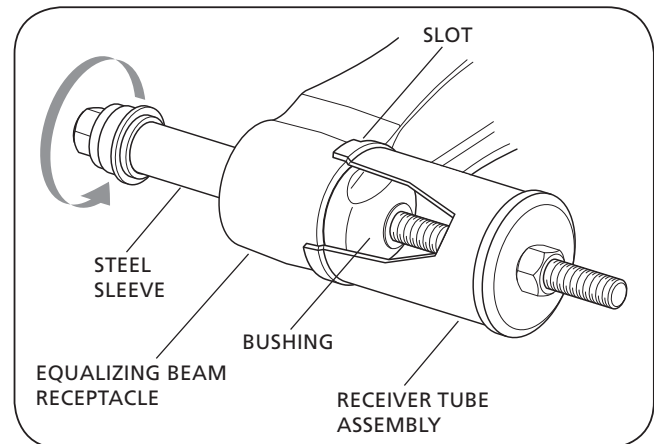

Figure 5



Bushing Replacement Instructions

- Clean out all foreign material from bushing receptacle(s) with a wire brush or wire wheel.
- Lubricate new bushing(s) with liquid dish soap and water solution.

IMPORTANT: DO NOT use oil-based lubricant or brake fluid, as they can cause damage to the bushing.

- Place new pivot bushing on threaded rod and lubricate the rod with a silicone lubricant. Place bushing adaptor onto receptacle (**Figure 6**).
- Position pivot bushing and threaded rod up against bushing adaptor.

NOTE: Slots on the bushing adaptor MUST align with the ribs of the equalizing beam to ensure proper fit to the equalizing beam.

- Thread rod into receiver tube assembly (**Figure 6**).

NOTE: Some models may require proper bushing orientation refer to suspension maintenance manual for proper orientation of new bushing(s).

- Using proper wrench as indicated above apply torque to drive nut and force new pivot bushing into beam receptacle(s) (**Figure 6**).

IMPORTANT: New bushing MUST be centered in bushing receptacle after force has been removed (**Figure 7**).

IMPORTANT: It may be necessary to push bushing past center approximately 1" (25.4 mm) and then recenter the bushing.

- Reassemble the front pivot connection using all new hardware (**Figure 2**).

NOTE: Always refer to suspension maintenance manual for reassembly of pivot connection.

- Raise the trailer approximately 2" inches above ride height and remove jack stands.
- Slowly lower the trailer so that the trailer suspension is fully collapsed. Reattach the lower connection of the Height Control Valve linkage.
- Apply air to the trailer and allow the suspension to return to ride height.
- Remove wheel chocks.
- Check for proper axle alignment. If realignment is necessary, refer to suspension maintenance manual for alignment procedure.

Figure 6

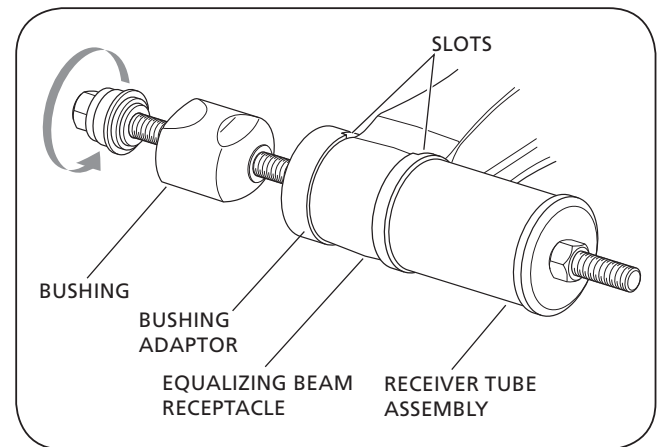
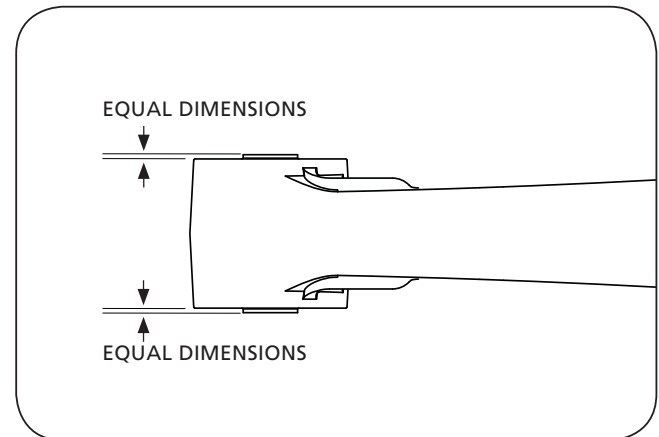

Figure 7





From fifth wheel rebuild kits to suspension bushing repair kits, SAF-HOLLAND Original Parts are the same quality components used in the original component assembly.

SAF-HOLLAND Original Parts are tested and designed to provide maximum performance and durability. Will-fits, look-alikes or, worse yet, counterfeit parts will only limit the performance potential and could possibly void SAF-HOLLAND's warranty. Always be sure to spec

SAF-HOLLAND Original Parts when servicing your SAF-HOLLAND product.

SAF-HOLLAND USA • 888.396.6501 • Fax 800.356.3929
www.safholland.us

SAF-HOLLAND CANADA • 519.537.3494 • Fax 800.565.7753
WESTERN CANADA • 604.574.7491 • Fax 604.574.0244
www.safholland.ca

SAF-HOLLAND MEXICO • 52.1.55.5456.8641 • Fax 52.55.58162230
www.safholland.com.mx

info@safholland.com