



GO THE DISTANCE.

AIRLITE2

PARTS LIST



AirLite2 Air Ride Suspension/ Slider Package for Van and Reefer Trailer Applications

Suspension and Slider Parts List
Information

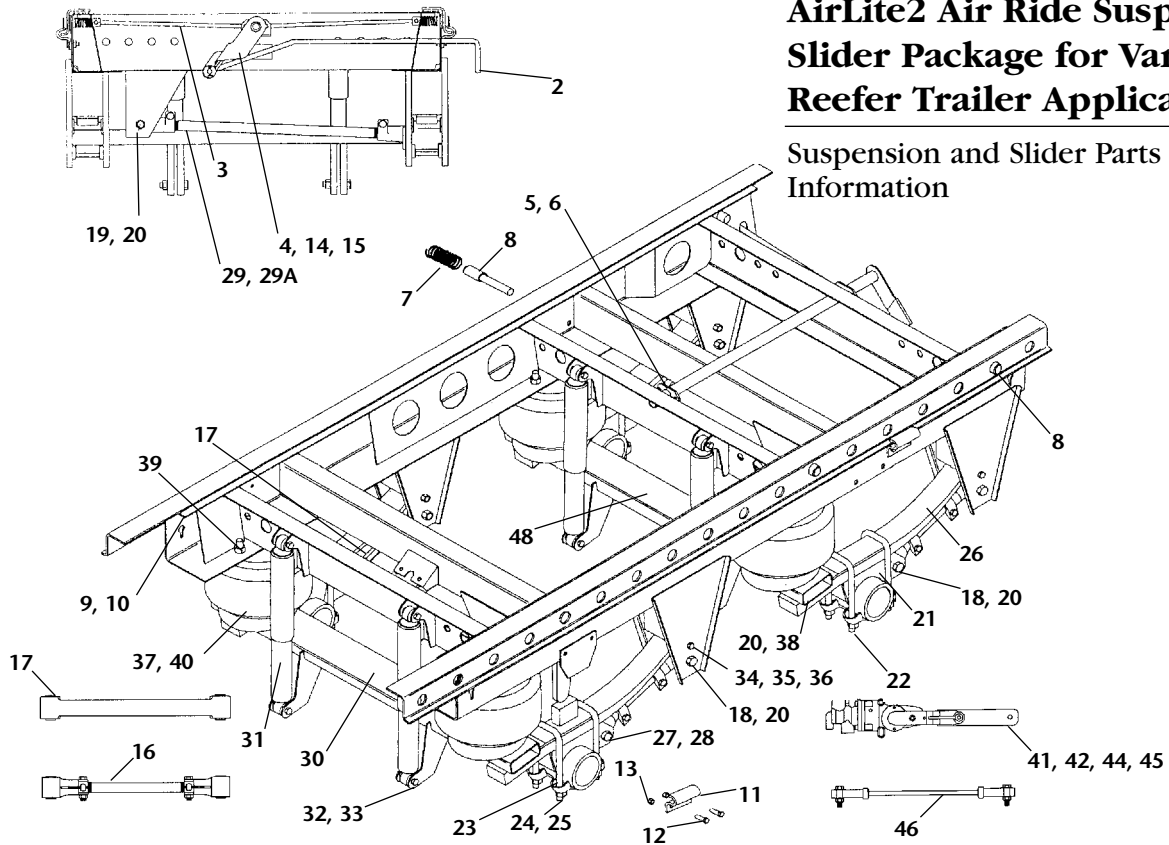

AirLite2 Air Suspension Parts List

ITEM NO.	DESCRIPTION	HOLLAND PART NO.	QTY.
1	W/A, Sub Frame	N/A	1
2	Arm, Pull	42" - SLOA1122-42 48" - SLOA1122-48	1
3	Arm, Linkage	42" - SLOA1058-02 48" - SLOA1058-01	4
4	Qwik Release® Replacement Kit	SL0019-01	1
5	Spacer	SL00523-01	1
6	Torsion Cam	SL0994	1
7	Spring, Compression	XB-SPG-020-33	4
8	Pin, Step Lock	SLOA1056	4
9	Self Tap Screw 3/16"-18 x 3/4"	XB-STS-008-16	16
10	Slider Pad 96" (Long)	XB-SLOA1054	2
11	Bracket, Hold Down	SL0893	4
12	Screw, Hex Cap 1/2"-13 x 1 1/4"	XB-HHC-001-33	8
13	Lock Nut 1/2"-13	XB-SLN-012-42	8
14	Cotter Pin 3/16" x 1 1/2"	XB-CTP-014-59	1
15	Flat Washer	XB-PW-016-08	1
16	Assembly, Adjustable Torque Arm	SP0202-01	2
17	Assembly, Fixed Torque Arm	SP0224	2
18	Screw, Hex Cap 7/8"-14 x 5 1/2"	XB-SP0050-72	8
19	Screw, Hex Cap 7/8"-14 x 4.81"	XB-SP0050-75	4
20	Nut, Hex Flange 7/8"-14	XB-SP0012-36	16
21	W/A, Spring Seat Riser	See Chart 2 (next pg)	4
22	Bottom Plates	SP0099/SP0192	4
23	Flat Top U-Bolts	See Chart 2 (next pg)	8
24	Nut, Hex 3/4"-16	XB-SP0011-44	16

AirLite2 Air Suspension Parts List

ITEM NO.	DESCRIPTION	HOLLAND PART NO.	QTY.
25	Washer, Flat-Hardened	XB-SP0016-67	16
26	Spring - Low Arch	XB-SP0205-01	4
27	Spring Liner Upper	XB-SP0203	4
28	Spring Liner Lower	XB-SP0204	4
29	Assembly, Cross Arm	42" - SP0202-09 48" - SP0202-10	2
30	W/A, Lower Beam Rear	See Chart 1 (next pg)	1
31	Shock Absorber, Monroe	XB-SPN-053-36	4
32	Screw, Hex Cap 3/4"-10 x 3 1/4"	XB-SP0050-99	8
33	Nut, Self-Locking, 3/4"-10	XB-SP0012-49	8
34	Screw, Hex Hd. Cap 5/8"-11 x 5 1/4"	XB-SP0050-101	4
35	Spacer, Sleeve	SP0221	4
36	Nut, Hex Self-Locking, 5/8"-11	XB-SP0012-10	4
37	Air Spring, Firestone	XB-SPN-053-60	4
38	Screw, Hex Hd. Cap 7/8"-14 x 2 1/2"	XB-SP0050-100	4
39	Nut, Hex Self-Locking, 3/4"-16	XB-SP0012-51	4
40	Nut, Hex Self-Locking, 1/2"-13	XB-SP0012-52	8
41	Hadley 500 LV*	XB-SPN-053-58	1
42	Hadley 500 LV* with auto dump	XB-SPN-053-54	1
43**	Hadley Pressure Protection Valve	XB-SPN-053-61	1
44	Manual Switch Valve	XB-SPN-052-51	1
45	Screw, Hex Hd. Cap 1/4"-20 x 2 1/2"	XB-HHC-050-109	2
46	Lock Nut, 1/4"-20	XB-SLN-012-60	2
47	Assembly, Hadley Link, 10.50" LG	XB-SPN-053-62	1
48	W/A, Lower Beam Front	See Chart 1 (next pg)	1

* LV = Leveling Valve.

** Item 43 not shown in diagram.

AIRLITE 2 SUSPENSION PARTS LIST *continued*

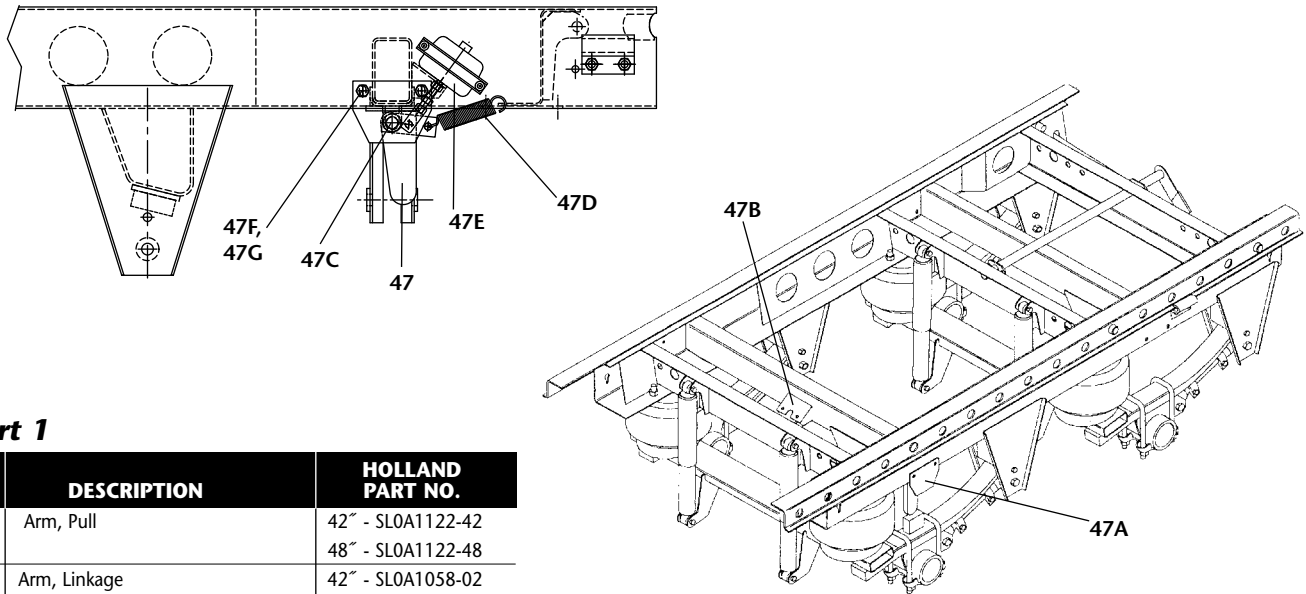

Chart 1

ITEM NO.	DESCRIPTION	HOLLAND PART NO.
2	Arm, Pull	42" - SLOA1122-42 48" - SLOA1122-48
3	Arm, Linkage	42" - SLOA1058-02 48" - SLOA1058-01
29	Cross Arm Assy.	42" - SP0202-09 48" - SP0202-10
29A	Center Link	42" - SP0206-02 48" - SP0206-03
30	W/A, Lower Beam, Rear (without air level)	42" - SP0278-42 48" - SP0278-48
	W/A, Lower Beam (with air level)	42" - SP0284-42 48" - SP0284-48
48	W/A, Lower Beam, Front	42" - SP0277-42 48" - SP0277-48

AirLite2 Optional Air Level

ITEM NO.	DESCRIPTION	HOLLAND PART NO.	QTY.
47	W/A, Air Level Cam	SLOA1134-48/42	1
47A	Assy., Cam Bracket	SLOA1124	2
47B	Bracket, Mounting Air Chamber	SLOA1129	1
47C	Support Shaft	SLOA1123	1
47D	Spring Extension	XB-SPG-020-34	1
47E	Service Chamber	SL0969	1
47F	Screw, Hex Cap 1/2"-13 x 1-1/4"	XB-HHC-001-33	4
47G	Lock Nut 1/2"-13	XB-SLN-012-42	4

Chart 2

ITEM NO.	DESCRIPTION	RIDE HEIGHT/SEAT HEIGHT			
		16.0" / 3/4"	16.5" / 1-1/4"	17.0" / 1-3/4"	17.5" / 2-1/4"
21	W/A, Spring Seat Riser	SP0142-01	SP0142-02	SP0142-03	SP0142-04
23	Flat Top U-Bolts	XB-SP0074-H	XB-SP0074-J	XB-SP0074-K	XB-SP0074-L

www.thehollandgroupinc.com

Copyright © March 2007 • The Holland Group, Inc.

Holland USA, Inc. Facilities:
 Denmark, SC Muskegon, MI
 Dumas, AR Warrenton, MO
 Holland, MI Wylie, TX
 Ph: 888-396-6501 Fax: 800-356-3929

Holland International, Inc.
 Holland, MI
 Phone: 616-396-6501
 Fax: 616-396-1511

Holland Hitch of Canada, Ltd.
 Woodstock, Ontario • Canada
 Phone: 519-537-3494
 Fax: 800-565-7753

Holland Equipment, Ltd.
 Norwich, Ontario • Canada
 Phone: 519-863-3414
 Fax: 519-863-2398

Holland Hitch Western, Ltd.
 Surrey, British Columbia • Canada
 Phone: 604-574-7491
 Fax: 604-574-0244