

SAF **CBXSSA**

LIGHTWEIGHT SUSPENSION SYSTEM WITH
PROVEN SAF SELF STEERING AXLE TECHNOLOGY

THE CBXSSA LIGHTWEIGHT SELF STEERING AXLE

For the first time in North America, a completely pre-engineered single sourced suspension/self-steering axle system that considers wheel cuts, tire clearances, SPIF regulations**, suspension travel, and lift capabilities – ready for installation at the trailer OEM. SAF-HOLLAND has combined the CBX lightweight suspension with SAF self steering axle technology. Together, they represent the first true systems solutions from a single source in North America!

The SAF CBX Series self steering axle suspension delivers one of the lightest weight, cost effective and pre-engineered solutions to address customer requests regarding “matching” of various sourced axle and suspension designs.

SYSTEM BENEFITS

- Reduced Rolling Resistance
- Less Frame and Suspension Damage
- Reduced Maintenance
- Reduced Tire Wear
- Greater Maneuverability

** Safe, Productive and Infrastructure-Friendly (SPIF) vehicle designations per Ontario Ministry of Transportation VW&D regulations.

MODEL CAPACITIES

25,000 lbs. CBX25
30,000 lbs.* CBX25/30
* The CBX25/30 is rated for 30,000 lbs. of load carrying at creep speed. Creep speed is defined as 5 mph or less.

Swing Align™

The fastest and most convenient axle alignment system in the industry.

No replacement parts or disassembly is required. Axle alignment adjustment is made directly by the lead screw. Requires less than 250 ft. lbs. of torque to adjust.

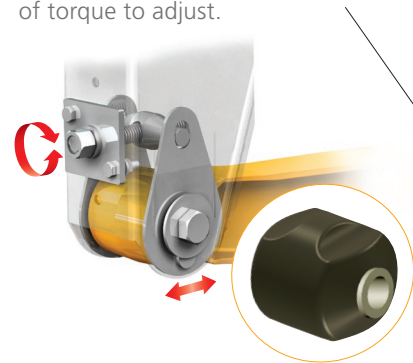

Multi-Functional Pivot Bushing

A robust bushing with its exterior void design limits the twisting movement that could lead to premature bushing and tire wear.

A LIGHT WEIGHT, COST EFFECTIVE, PRE-ENGINEERED SOLUTION



Thrust washers

Double set of thrust washers – one on either face of pivot arm. Completely sealed against dust, dirt, moisture and other contaminants.

Heavy-duty steering arm

Robust design for improved durability. Precisely machined to adapt to standard heavy-duty tie rod ends.

Leading kingpin design

2-3/8" hardened pin with lubricated bronze bushings.

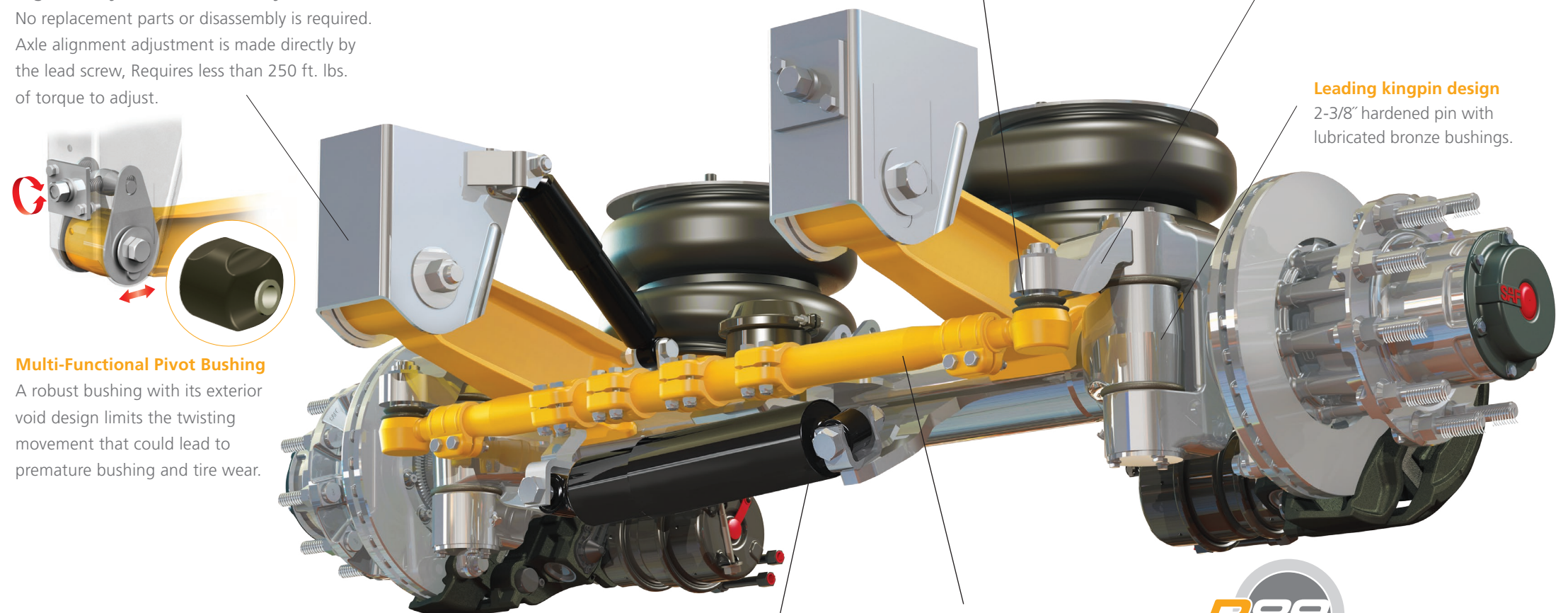

Adjustable tie rod

Durable design with adjustable tapered ends – allows for length adjustment (toe-in) and centering.

Double acting self centering – steer damper

The combination of offset steering knuckle and special-steering dampener eliminates flutter movements and provides exceptional tracking.



Premium Maintenance Free Design

Featuring the legendary INTEGRAL® rotor/hub and premium sealed bearings for reduced maintenance. Includes a 7-year warranty.

Disc brakes simply provide better performance than drum brakes. They stop shorter for increased safety and reduced maintenance for lower total cost of ownership.

SUPERIOR CORROSION PROTECTION



BLACK ARMOUR™ IS STANDARD WITH AEROBEAM



LIFT AXLE OPTIONS FOR THE CBXSSA

CBL (CENTER BAG LIFT)



The lightweight CBL features a proven, simple axle lift that provides ample ground clearance. Designed for easy installation, the single, larger lift capacity air bag is positioned below the suspension frame bracket mount location and centered between the trailer chassis for tight clearance applications.

HEAVY-DUTY POSILIFT™



The light, simple and durable design of the SAF heavy-duty PosiLift™ provides a twin bag lift solution where a conventional Center Bag Lift will not fit within the trailer chassis (e.g. hoppers, bottom discharge bulk tankers, etc.). The lift system allows the self steering axle to be lifted while backing up, and for tight maneuvering in a yard, or when running empty (as regulations allow).



CBXSSA SPECIFICATIONS

CBX25 & CBX25/30 MODELS WITH SAF SELF STEERING AXLE

FEATURES	STANDARD	OPTIONS
Ride Heights	14", 15", 16", 17", 18" & 19"	Upon Request
Steer Angle	20°	25° – 30°
Swing Align™	•	NA
Air Springs with ¼" Ports	•	NA
Tire Track	77.5", 85", 87" WBS (385/65 R22.5)	NA
Lift Axle System		CBL (Center Bag Lift) HD PosiLift
Camber and Toe Preset at Factory	•	

WITH DISC BRAKES STANDARD INTEGRAL® AIR DISC BRAKE AXLE WITH P89 PLUS

FEATURES	STANDARD	OPTIONS
Axle Diameter	5.75"	NA
Spindle	Parallel	NA
Fully Dressed	•	NA
Dust Shields	•	NA
Stud Length	Long	Short

WITH DRUM BRAKES STANDARD DRUM BRAKE AXLE

FEATURES	STANDARD	OPTIONS
Axle Diameter	5.75"	NA
Spindle	Parallel	NA
Drum Brake	16½" x 7"	NA
Extended Life Lining	SAF Standard 23k	NA
Cam Enclosures	•	NA
Dust Shields		•
Slack Adjustors	•	NA
Fully Dressed with ABS Sensors		•
Fully Dressed without ABS Sensors		•

NOTE: Other configurations may be available. Contact Trailer Applications Engineering.

SAF Holland Group



TRAILER AXLES AND
SUSPENSION SYSTEMS



COUPLING AND
LIFTING SYSTEMS



SUSPENSIONS FOR
TRUCKS AND BUSES



SUSPENSIONS AND
AXLE SYSTEMS



BUS AIR SUSPENSION
SYSTEMS



V. ORLANDI
TOWING
SYSTEMS



TRAILER AXLES/SUSPENSIONS,
COUPLING AND LIFTING
SYSTEMS

safholland.com

SAF-HOLLAND, Inc.

888.396.6501 Fax 800.356.3929

SAF-HOLLAND Canada Limited

519.537.3494 Fax 800.565.7753

Western Canada 604.574.7491 Fax 614.574.0244