



SAF ●

CBXu & CBXy SERIES

THE CBXu AND CBXy SUSPENSIONS DELIVER
DURABILITY IN A LIGHTWEIGHT SYSTEM
FOR LOW PROFILE TRAILER APPLICATIONS

CBXu SERIES UNDERSLUNG AIR SUSPENSION AXLE SYSTEM

The CBXu and CBXy suspensions deliver durability in a lightweight system for low profile on- and off-highway trailer applications. Models with capacities of 23,000, 25,000 and 30,000 lbs. are available for drop-decks, lowboys and low profile specialty trailers. Models are available with ride heights ranging from 6 to 12 inches.

CBX models are equipped with SAF 5.75" diameter axles for increased stiffness, even tire tread wear and reduced weight. The CBU and CBy models with 5" SAF axles allow smaller drum brake configurations for low profile applications that require 17.5 and 19.5" wheel sizes.

BLACK ARMOUR SUPERIOR CORROSION PROTECTION
BLACK ARMOUR™ IS STANDARD WITH AEROBEAM ECO-FRIENDLY

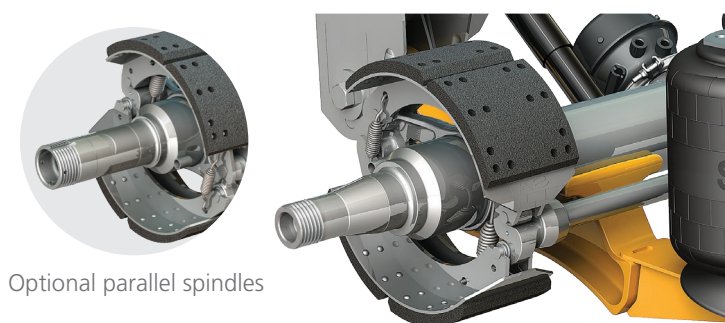

Optional parallel spindles

Drum Brake Axle is Standard Equipment

The SAF CBX25u standard configuration features a SAF X-Series 5.75" diameter axle with 16½" x 7" extended life brake linings and industry standard taper spindles. Optional parallel spindles available.

With standard drum brakes, the CBXu model provides optimum ground clearance by locating the spring brakes and camshafts even with the axle.

MODEL CAPACITIES

23,000 lbs. CBX23u
 25,000 lbs. CBX25u
 30,000 lbs. * CBX25/30u
 * The CBX25/30 is rated for 30,000 lbs. of load carrying at creep speed. Creep speed is defined as 5 mph or less.

Swing Align™

The industry's fastest, most convenient and least expensive axle alignment system. Requires no replacement parts or disassembly. Axle alignment is achieved by direct adjustment of the lead screw, requiring less than 250 ft. lbs. of torque.

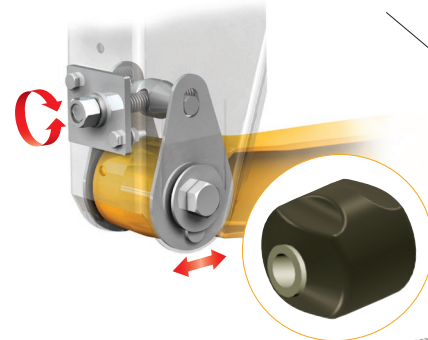

Multi-Functional Pivot Bushing

A more robust bushing with exterior void design limits the twisting movement that could lead to premature bushing and tire wear.



CBXu SERIES



**LIGHTWEIGHT DURABILITY
FOR LOW PROFILE TRAILERS**

The CBX25/30 Model is Rated for 30,000 lbs. of Load Carrying Capacity at Creep Speed*

The CBX25/30 is specifically designed to address additional load transfer to the primary suspensions when lift axles are raised, typically encountered in tight maneuvering situations. The CBX25/30 delivers the additional load capacity through a larger air spring.

* Creep speed is defined as 5 mph or less.

OPTIONAL **P89 Series**
AIR DISC BRAKES

Two Model Choices to Meet your Fleet's Specific Needs

The P89 model at a price point that makes sense for fleets of any size. And, the P89 Plus for premium performance. Disc brakes simply provide better performance than drum brakes. They stop shorter for increased safety and reduced maintenance for lower total cost of ownership.

Lightweight Cast Steel Trailing Arm Beam Design

Cast beam design meets the demand for durability while providing a low overall system weight.

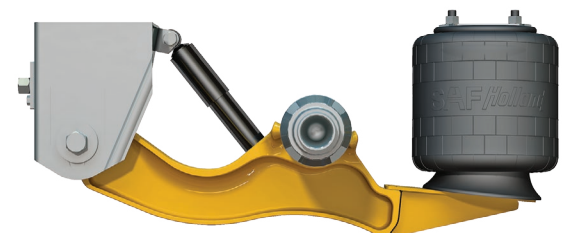

CBX_y SERIES

INTEGRATED YOKE MOUNT SUSPENSION AXLE SYSTEM

MODEL CAPACITIES

25,000 lbs. CBX25_y
30,000 lbs. CBX25/30_y*

* The CBX25/30_y is rated for 30,000 lbs. of load carrying at creep speed. Creep speed is defined as 5 mph or less.

The Industry's First Integrated Yoke Mount Suspension Axle System For Low Profile Lowboy Trailer Applications

Designed to work in conjunction with the low profile CBXu underslung model, the CBX_y includes the same proven CBX feature benefits you have come to depend on. The cast steel yoke mount beam provides strength in a lightweight design and BLACK ARMOUR™ provides the ultimate in corrosion protection. The SAF 5.75" diameter axle comes with the P89 Series air disc brakes or drum brake wheel end packages.

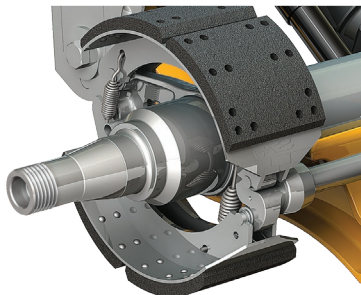

Available with P89 Series air disc brake or drum brake wheel end packages with industry standard tapered spindles or optional parallel spindles.

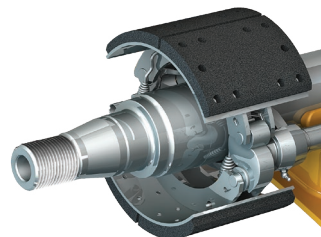

Smaller drum brake configurations are available with the CBU and CBy suspension models.

OPTIONAL P89 SERIES AIR DISC BRAKES

**INDUSTRY LEADING
AIR DISC BRAKE
WARRANTY**

See XL-AS11002WC warranty statement for complete details.



Proven Design Quality
with Genuine Value

All the benefits you expect from the world's leading trailer axle disc brake supplier, at a price point that makes sense for commercial fleets of all sizes.

Featuring:

- Heavy-duty venter rotor • SAF caliper
- Premium matched set bearings
- Parallel or taper spindle • 5-Year warranty

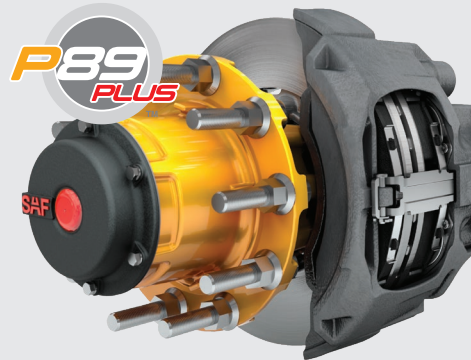

Premium Performance Maintenance
Free Design

Featuring the legendary INTEGRAL® rotor/
hub and premium sealed bearings for
reduced maintenance.

Featuring:

- INTEGRAL® rotor • Long-life sealed bearings
- Premium brake chambers • SAF caliper
- Robust parallel spindle • Premium spindle nuts
- 7-Year warranty

OPTIONAL TIRE PILOT PLUS™

By PressureGuard - A Division of SAF-HOLLAND

Optional Tire Pilot Plus™ not only controls pressure through inflation, but also maintains equal pressure across all wheels and features high pressure relief for overinflated tires. The robust design sets it apart from competitive designs with durable components.

- Diamond knurled hose connections at both hubcaps and tire valve ends allow installation and replacement without a wrench.
- The stainless steel air hose connections are ported through the sides of the hubcap and are protected
- System warning light alerts the driver only when there is a need to immediately seek service.

**IMPROVE PROFITABILITY
BY ENHANCING TIRE
LIFE, FUEL EFFICIENCY
AND UPTIME**



CBXu & CBXy SERIES SPECIFICATIONS

CBXu, CBu, CBXy & CBy

FEATURES	STANDARD	OPTIONS
Ride Heights	6", 7", 8", 9", 10" & 12"	NA
Swing Align™	•	
Fully Assembled	•	
Height Control Valve with Dump		•
Height Control Valve without Dump		•
Air Springs with 1/4" Ports	•	

STANDARD DRUM BRAKE AXLE

CBXu, CBu, CBXy & CBy

FEATURES	STANDARD	OPTIONS
Capacities	23,000, 25,000 & 30,000 lbs.*	NA
Axle Track	71½"	75½", 77½", 81½", 83½"***
Spindle	Tapered	Parallel
Drum Brakes**	CBXu & CBXy with 5.75" Dia. Axle	16½" x 7"
	CBu & CBy with 5" Dia. Axle	12¼" x 7½"
Extended Life Linings	CBXu & CBXy	SAF Std. 20K & 23k Available
	CBu & CBy	20k & 23K
Tire Inflation Prep	Drilled & Tapped Only	•
	Tire Pilot Plus™	•
	PSI	•
Cambered Axle		•
Cam Enclosures		•
Dust Shields		•
Fully Dressed with ABS Sensors (CBX models only)		•
Fully Dressed without ABS Sensors (CBX models only)		•

OPTIONAL DISC BRAKE AXLE WITH P89 SERIES

CBXu, CBu, CBXy & CBy

FEATURES	STANDARD	OPTIONS
Capacities	23,000, 25,000 & 30,000 lbs.*	NA
Axle Track	71½"	75½", 77½", 81½", 83½"***
Spindle	P89	
Fully Dressed with ABS Sensors Installed	•	NA
Cambered Axle		•
Dust Shields	•	
Stud Length	Long	Short
Tire Inflation Prep:	Drilled & Tapped Only	•
	Tire Pilot Plus™	•
	PSI	•
Wheel Size	22½"	24½"

* All 25/30 models are rated for on-highway operation and 30,000 lbs. of load carrying at creep speed. Creep speed is defined as 5 mph or less.

** Other brake configuration available. Contact Trailer Applications Engineering.

*** Other axle tracks available upon request.

THE CBu AND CBy
 MODELS MEET THE
 NEED FOR WHEEL/
 BRAKE CONFIGURATIONS
 SMALLER THAN THE
 INDUSTRY STANDARD
 22.5" WHEELS

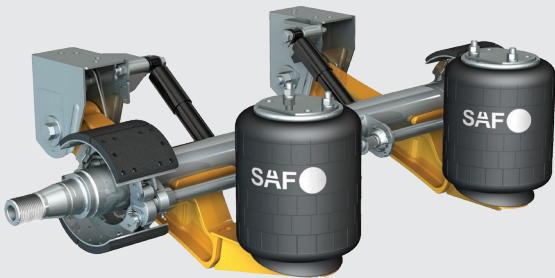

For low profile trailer applications that require 17.5" and 19.5" wheel sizes, the SAF CBu and CBy suspension models accommodate 12.25" x 7.5" drum brake packages. The CB models feature industry standard tapered spindles. Optional parallel spindles also available.

SYSTEM	CBX23	CBX25	CBX25/30
Undressed Drum Brake Axle (16.5" x 7" braked axle only – no slack adjusters or brake actuators)	558 lbs.	564 lbs.	608 lbs.
Dressed Drum Brake Axle (Includes steel hubs/drums, bearings, oil, slack adjusters and brake actuators)	912 lbs.*	918 lbs.*	962 lbs.*
P89 Disc Brake Axle	965 lbs.	971 lbs.	1,012 lbs.

*Optional lightweight dressed drum brake wheel ends available - 78 lbs. lighter.

APPLICATIONS

Versatile CBXu and CBXy Underslung Fixed Frame Series Suspensions are performance proven for specialty trailer applications.

- Drop Decks
- Low Boys
- Specialty Vans
- Moving Vans
- Chip Hauler
- Livestock
- Dry Bulk
- Auto Haulers



SAF CBX fixed frame suspension models are available for top mount trailer applications.

(See brochure XL-AS20025SL)



SAF Holland Group



TRAILER AXLES AND
SUSPENSION SYSTEMS



COUPLING AND
LIFTING SYSTEMS



SUSPENSIONS FOR
TRUCKS AND BUSES



SUSPENSIONS AND
AXLE SYSTEMS



BUS AIR SUSPENSION
SYSTEMS



V.ORLANDI
TOWING
SYSTEMS



TRAILER AXLES/SUSPENSIONS,
COUPLING AND LIFTING
SYSTEMS

safholland.com

SAF-HOLLAND, Inc.

888.396.6501 Fax 800.356.3929

SAF-HOLLAND Canada Limited

519.537.3494 Fax 800.565.7753

Western Canada 604.574.7491 Fax 614.574.0244