

**SAF CBX69 SERIES**  
TRIDEM AXLE SLIDER SYSTEM

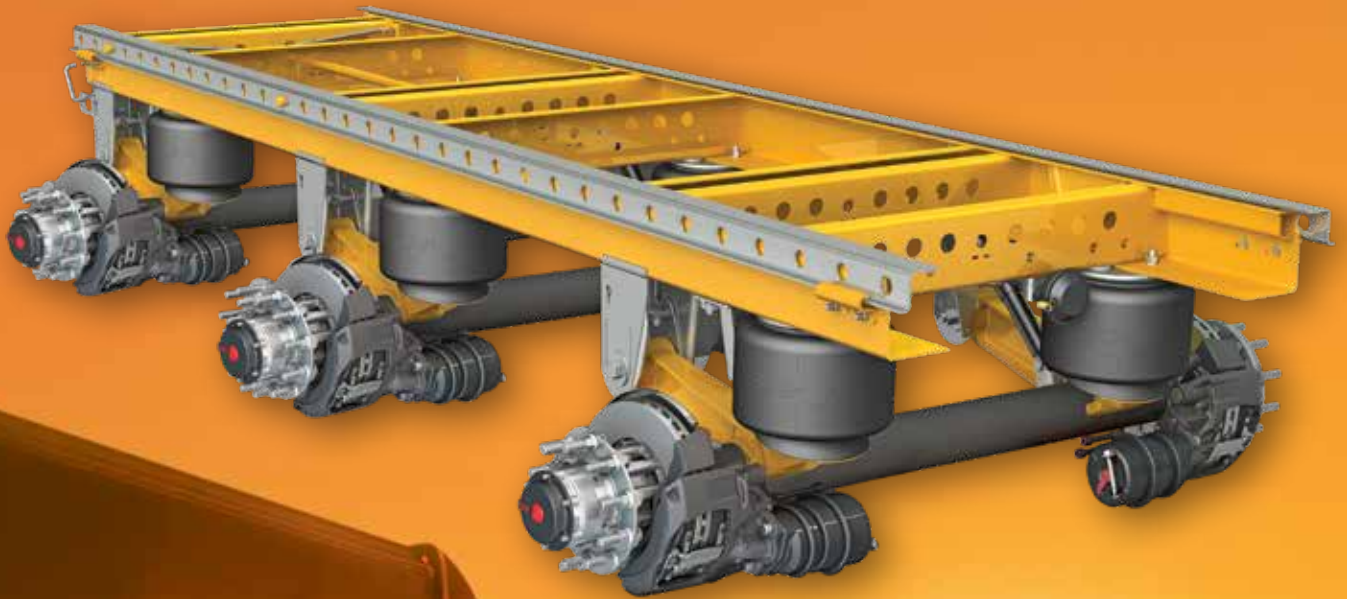

OPTIONAL  
**P89** Series  
™ AIR DISC BRAKES

SETTING A NEW STANDARD IN LIGHTWEIGHT  
69,000 LB. CAPACITY TRIDEM SLIDER  
SUSPENSION SYSTEMS

# SAF CBX69 TRIDEM AXLE SLIDER

## SLIDER SUB-FRAME

Strategic placement of full height crossmembers help resist racking and buckling for extended service and durability.

69,000 lbs.  
**CAPACITY**

## QWIK RELEASE™ PIN PULL

One person operation makes slider adjustment safe and efficient. With 20% less pulling effort than competitive models.

## CAST BEAM TECHNOLOGY

Lightweight cast beam design optimizes strength-to-weight ratios to maximize durability.

## DRUM BRAKE AXLE IS STANDARD EQUIPMENT

The SAF CBX69 standard configuration features a SAF X-Series 5.75" diameter axle with 16½" x 7" extended life brake linings.



LEARN MORE ABOUT SWING ALIGN™

## POSILOK™

Eliminates dock walk and squat. Creates stable and safe loading and unloading operations.



## SWING ALIGN™

The fastest and most convenient axle alignment system in the industry. No replacement parts or disassembly is required.

## BLACK ARMOUR™ IS STANDARD ON CBX69



  
**ECO-FRIENDLY**

The BLACK ARMOUR™ metal protection process, unlike a primer, paint or powder coating, chemically bonds with metal to form a protective skin that is impervious to water and anti-icing chemicals. This eco-friendly metal treatment provides remarkable protection without all the weight and cost of galvanization.



# ONE OF THE LIGHTEST WEIGHT TRIDEM SYSTEMS IN ITS CLASS

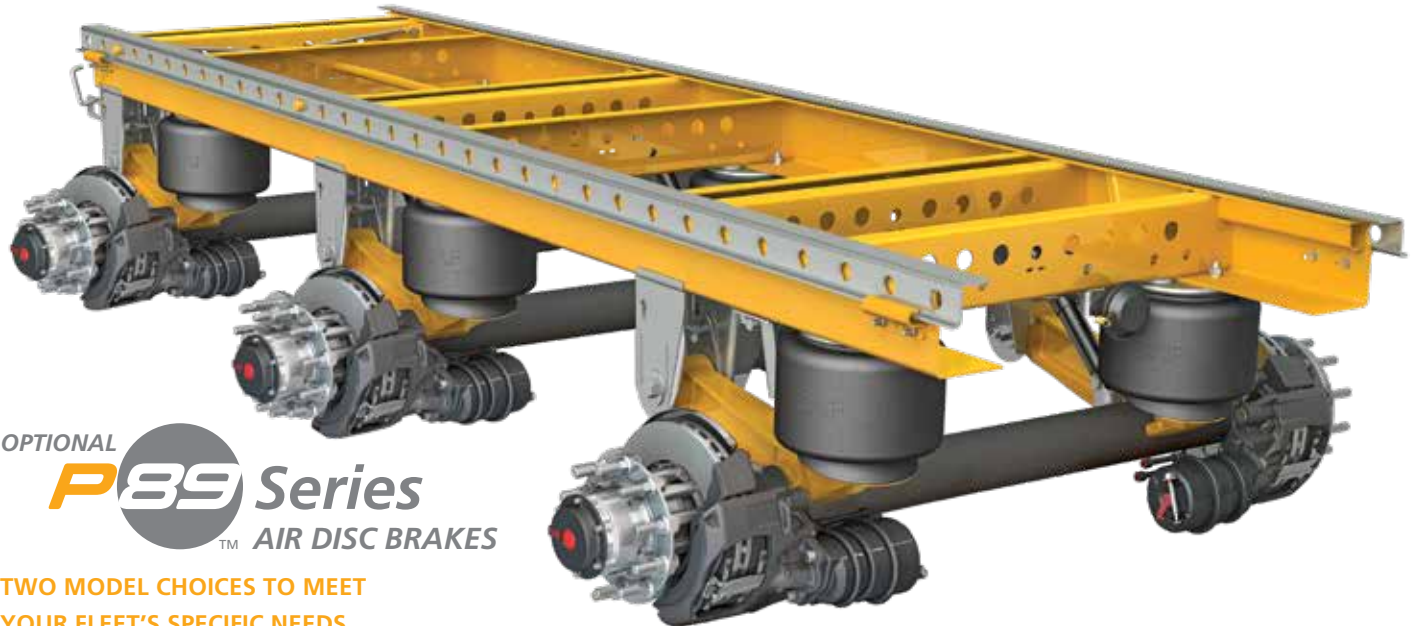

OPTIONAL  
**P89** Series  
™ AIR DISC BRAKES

## TWO MODEL CHOICES TO MEET YOUR FLEET'S SPECIFIC NEEDS

The P89 model at a price point that makes sense for fleets of any size. And, the P89 Plus for premium performance. Disc brakes simply provide better performance than drum brakes. They stop shorter for increased safety and reduce maintenance for lower total cost of ownership.

### THE CBX69 TRIDEM DELIVERS THE FEATURES AND BENEFITS OF THE CBX40 IN A TRIPLE-AXLE CONFIGURATION

CBX69 tridem sliders utilize lightweight CBX air ride suspension systems and proven slider box technology for superior durability with best-in-class weight savings. Tridems provide the versatility to move freight across international, provincial and state borders while remaining in compliance with bridge/weight regulations and Canadian SPIF "infrastructure-friendly" regulations.

The CBX69 sets a new standard for lightweight tridem suspension slider axle systems. The slider box design provides an outstanding strength-to-weight ratio for increased cargo. Additionally SAF X-Series 5.75" diameter axle with a lightweight, yet robust 11mm wall axle allows for higher duty cycle applications.





# OPTIONAL P89 SERIES AIR DISC BRAKES

## PROVEN DESIGN QUALITY WITH GENUINE VALUE

All the Benefits You Expect From the World's Leading Trailer Axle Disc Brake Supplier, at a Price Point That Makes Sense for Commercial Fleets of All Sizes

### Featuring

- Heavy-Duty Vented Rotor
- SAF Caliper
- Premium Matched Set Bearings
- Parallel or Taper Spindle
- 5-Year Warranty



## PREMIUM PERFORMANCE MAINTENANCE FREE DESIGN

Featuring the Legendary INTEGRAL® Rotor/Hub and Premium Sealed Bearings for Reduced Maintenance

### Featuring

- INTEGRAL® Rotor
- Long-Life Sealed Bearings
- Premium Brake Chambers
- SAF Caliper
- Robust Parallel Spindle
- Premium Spindle Nuts
- 7-Year Warranty



LEARN MORE  
ABOUT THE P89

**INDUSTRY LEADING AIR  
DISC BRAKE WARRANTY**

See XL-AS11002WC warranty statement for complete details.

**SAF**   
SAF-HOLLAND Group



Engineering Your Road to Success

**SAF-HOLLAND** is a leading supplier of highly efficient components, systems and service programs in the global commercial vehicle industry. Our three core product brands are recognized for delivering innovative solutions that optimize fleet operations in every corner of the world.



**TRAILER AXLES AND  
SUSPENSION SYSTEMS**



**COUPLING AND LIFTING  
TECHNOLOGIES**



**SUSPENSIONS FOR  
TRUCKS AND BUSES**

With our team of over 3,000 employees and a worldwide network of over 9,000 service partners, we serve our fleet customers with know-how and passion, and always focused on one target: **Engineering your road to success.** Anywhere in the world. Under any conditions. 365 days a year.

HIGHLY EFFICIENT COMPONENTS AND SYSTEMS FOR TRUCKS AND TRAILERS



EUROPE | AMERICAS | AFRICA | ASIA | MIDDLE EAST | AUSTRALIA

[safholland.com](http://safholland.com)

**SAF-HOLLAND, Inc.**  
888.396.6501 Fax 800.356.3929

**SAF-HOLLAND Canada Limited**  
519.537.3494 Fax 800.565.7753  
Western Canada 604.574.7491 Fax 604.574.0244

XL-AS2007SL-en-US Rev C · 2018-02-22 · Amendments and errors reserved ©SAF-HOLLAND, Inc.  
SAF-HOLLAND, SAF, BLACK ARMOUR, POSILIFT, and SAF-HOLLAND  
Original Parts logos are trademarks of SAF-HOLLAND S.A.,  
SAF-HOLLAND GmbH, and SAF-HOLLAND, Inc.

# SPECIFICATIONS

## CBX69 SERIES

FEATURES	STANDARD	OPTIONS
Ride Heights	16", 16½", 17" & 18"	NA
Slider Width	48"	42" & 54"
Patented Qwik Release® Pull Arm	•	
Air Release		•
Swing Align™	•	
Assembled System	•	
Max Valve Height Control Valve with Dump	•	
Max Valve Height Control Valve without Dump		•
Air Springs w/1/4" Ports	•	
PosiLok™ – Anti Dock Walk Device	•	
Slider Configured to Accommodate HOLLAND Body Rails	•	
Slider Configured to Accommodate Competitor Rails		•
Air Tank, Mud Flap & Stinger Brackets		•
HOLLAND Slider Rails	Order Separately	
Manual Stop Bars	Order Separately	

## STANDARD DRUM BRAKE AXLE PACKAGE

Axle Spread	72"	60"
Axle Diameter	5.75"	NA
Axle Wall Thickness	11 mm (.43")	NA
Axle Track	77½"	71½", 81½", 83½"*
Spindle	Tapered	Parallel
Drum Brake	16½" x 7"	16½" x 8⅝"
Extended Life Linings	SAF Standard 20k	SAF Standard 23k
Tire Inflation Prep: Drilled & Tapped Only		•
Stator Pipe & Freeze Plugs		•
Cam Enclosures		•
Dust Shields		•
Fully Dressed with ABS Sensors		•

## OPTIONAL P89 SERIES AIR DISC BRAKE AXLE PACKAGE

Axle Track	77½"	71½", 81½", 83½"*
P89 (5 Year System)	•	
P89 Plus (7 Year System)	•	
Spindle – New P89	Parallel	Taper
Spindle – P89 Plus	Parallel	NA
Fully Dressed with ABS Sensors Installed	•	NA
Dust Shields		•
Tire Inflation Prep: Drilled & Tapped Only		•
MTIS, Aeris or other commercially available systems		•

\* Other axle tracks available upon request.