

## SAF CBX25 SERIES

### AIR SUSPENSION AXLE SYSTEM



LIGHTWEIGHT COMPACT DESIGN  
10 TONNES CAPACITY SUSPENSION  
WITH DRUM OR DISC BRAKES

# SAF CBX25 FIXED FRAME AIR

## SWING ALIGN™

The industry's fastest, most convenient and least expensive axle alignment system. Requires no replacement parts or disassembly. Axle alignment is achieved by direct adjustment of the lead screw, requiring less than 250 ft. lbs. of torque.



## MULTI-FUNCTIONAL PIVOT BUSHING

The more robust bushing with its exterior void design limits the twisting movement that could lead to premature bushing and tire wear.



## DRUM BRAKE AXLE IS STANDARD EQUIPMENT

The SAF CBX25 standard configuration features a SAF X-Series 146 mm diameter 11 mm wall axle with 420 mm x 180 mm extended life brake linings and industry standard tapered spindles. Optional parallel spindles available.

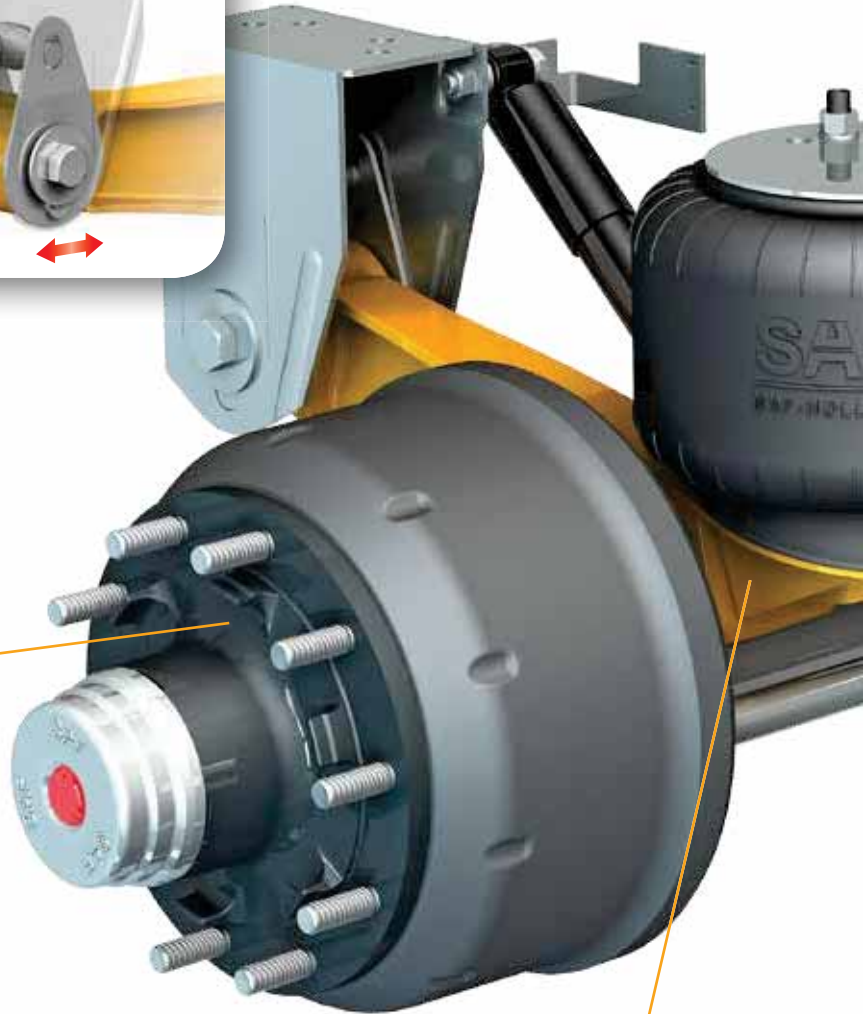

## OPTIONAL SAF INTEGRAL™ DISC BRAKES

The SAF INTEGRAL™ disc brake option is the lightest-weight design on the market today – provides reduced stopping distances while significantly lowering service costs and downtime with a Bi-Metallic rotor and maintenance free hub and bearing assembly.



## LIGHTWEIGHT SUSPENSION BEAM DESIGN

Reduced beam weight without compromising beam strength or integrity. This is accomplished through welding a fabricated tail section to a cast beam.



# R SUSPENSION AXLE SYSTEM

10 tonnes  
**CAPACITY**



### OPTIMIZED AXLE SOLUTIONS

The SAF X-Series 146 mm axle with standard 11 mm wall provides the optimal balance of strength and weight. Equipped with standard drum brakes or optional INTEGRAL™ disc brakes.

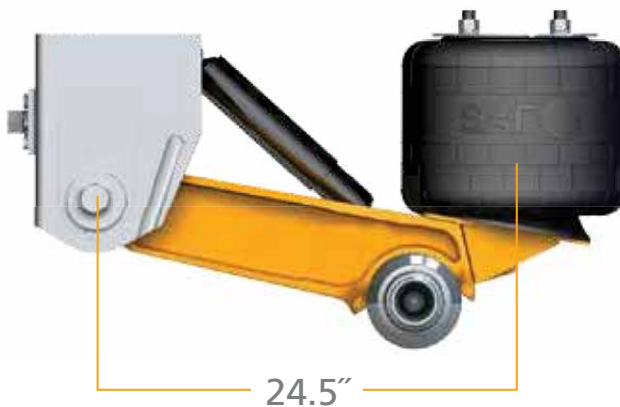

### LIGHTWEIGHT TRAILING ARM BEAM DESIGN

Versatile, lightweight beam design for significantly lower overall system weight and greater application adaptability.

When equipped with optional SAF INTEGRAL™ disc brakes, the CBX25 is the lightest weight 25k disc brake suspension available.

SUSPENSION SYSTEM WEIGHTS	CBX25
Drum Brake Axle System	450 kg
Disc Brake Axle System	387 kg

# POSILIFT™

## OPTIONAL LIFT AXLE SYSTEM

Light, durable and easy to install, SAF's PosiLift Axle Lift System allows operators to easily increase payload with just the flip of a switch. In addition to increased payload capacity, liftable axles also provide an opportunity to extend tire life, improve operational versatility and fuel efficiency, as well as enhancing trailer maneuverability.

### POSILIFT™ FEATURES

- Compact Design
- Simple Under Axle Lift
- Easy to Install or Retrofit



Designed with simplicity and durability in mind.  
PosiLift™ is light, simple to install, and easy to maintain.



# SPECIFICATIONS

## CBX25

FEATURES	STANDARD	OPTIONS
Ride Heights	385 - 445 mm	Upon Request
Swing Align™	•	
Air Springs with 1/4" Ports	•	
PosiLift™ Lightweight Lift Axle System		•

## STANDARD DRUM BRAKE AXLE PACKAGE

Axle Diameter	146 mm	NA
Axle Wall Thickness	11 mm (.43")	NA
Axle Track	1830 mm	2040 mm
Spindle	Tapered	NA
Drum Brake	420 x 180	420 x 200
Tire Inflation Prep: Drilled & Tapped Only		•
Dust Shields	•	
Fully Dressed with ASB Sensors		•

## OPTIONAL INTEGRAL™ DISC BRAKE

Axle diameter	146 mm	NA
Axle Wall Thickness	11 mm (.43")	NA
Axle Track	1830 mm	2040 mm
Fully Dressed with ASB Sensors	•	NA
Dust Shields	•	
Tire Inflation Prep: MTIS (Stator Pipe & Freeze Plugs)		•

\* Other axle tracks available upon request.





From fifth wheel rebuild kits to suspension bushing repair kits, SAF-HOLLAND Original Parts are the same quality components used in the original component assembly. SAF-HOLLAND Original Parts are tested and designed to provide maximum performance and durability. Will-fits, look-alikes or, worse yet, counterfeit parts will only limit the performance potential and could possibly void SAF-HOLLAND's warranty.

Always be sure to spec SAF-HOLLAND Original Parts when servicing your SAF-HOLLAND product.

XL-AS20021SL-en-CN Rev A · 2013-10-07 · Amendments and errors reserved ©SAF-HOLLAND, Inc.  
SAF-HOLLAND, SAF, BLACK ARMOUR, POSILIFT, and SAF-HOLLAND Original Parts logos are trademarks of SAF-HOLLAND S.A., SAF-HOLLAND GmbH, and SAF-HOLLAND, Inc.

## HIGH QUALITY COMPONENTS FOR THE COMMERCIAL VEHICLE INDUSTRY

AXLES & SUSPENSION

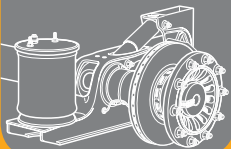

LANDING GEAR

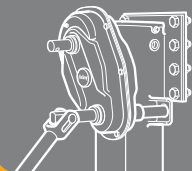

KINGPINS



FIFTH WHEELS

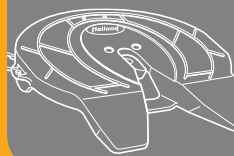

COUPLING PRODUCTS



EUROPE · NORTH AMERICA · SOUTH AMERICA · AFRICA · ASIA · AUSTRALIA

SAF-HOLLAND USA, Inc.  
888.396.6501 Fax 800.356.3929

AF-HOLLAND (Xiamen) Co., Ltd.  
86.592.6369202 Fax 86.592.6288892

[www.safholland.com](http://www.safholland.com)

