

SAF CBX25 SERIES
AIR SUSPENSION AXLE SYSTEM



LIGHTWEIGHT COMPACT DESIGN
11,363 KG CAPACITY SUSPENSION
WITH DRUM OR DISC BRAKES

SAF CBX25 FIXED FRAME AIR

SWING ALIGN™

The industry's fastest, most convenient and least expensive axle alignment system. Requires no replacement parts or disassembly. Axle alignment is achieved by direct adjustment of the lead screw, requiring less than 340Nm of torque.



CBX25-287

MULTI-FUNCTIONAL PIVOT BUSHING

The more robust bushing with its exterior void design limits the twisting movement that could lead to premature bushing and tire wear.



DRUM BRAKE AXLE IS STANDARD EQUIPMENT

The SAF CBX25 standard configuration features a SAF X-Series 146 mm diameter 11mm wall axle with 419 mm x 203 mm extended life brake linings and industry standard tapered spindles. Optional parallel spindles available.

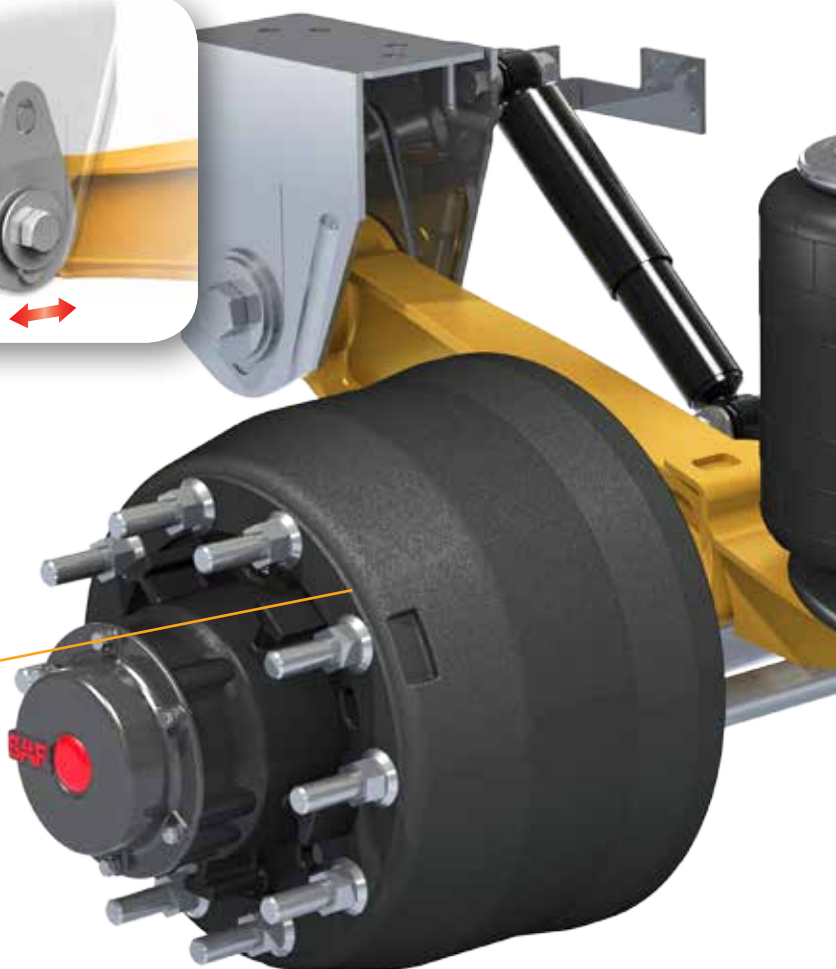

AVAILABLE FOR SUPER SINGLE

OPTIONAL SAF INTEGRAL® DISC BRAKES

The SAF INTEGRAL® disc brake option is the lightest-weight design on the market today – provides reduced stopping distances while significantly lowering service costs and downtime with a Bi-Metallic rotor and maintenance free hub and bearing assembly.



LIGHTWEIGHT TRAILING ARM BEAM DESIGN

Versatile, lightweight beam design for significantly lower overall system weight and greater application adaptability.



R SUSPENSION AXLE SYSTEM

11,363 kg
CAPACITY



OPTIMIZED AXLE SOLUTIONS

The SAF X-Series 146 mm axle with standard 11 mm wall provides the optimal balance of strength and weight. Equipped with standard drum brakes or optional INTEGRAL® disc brakes.

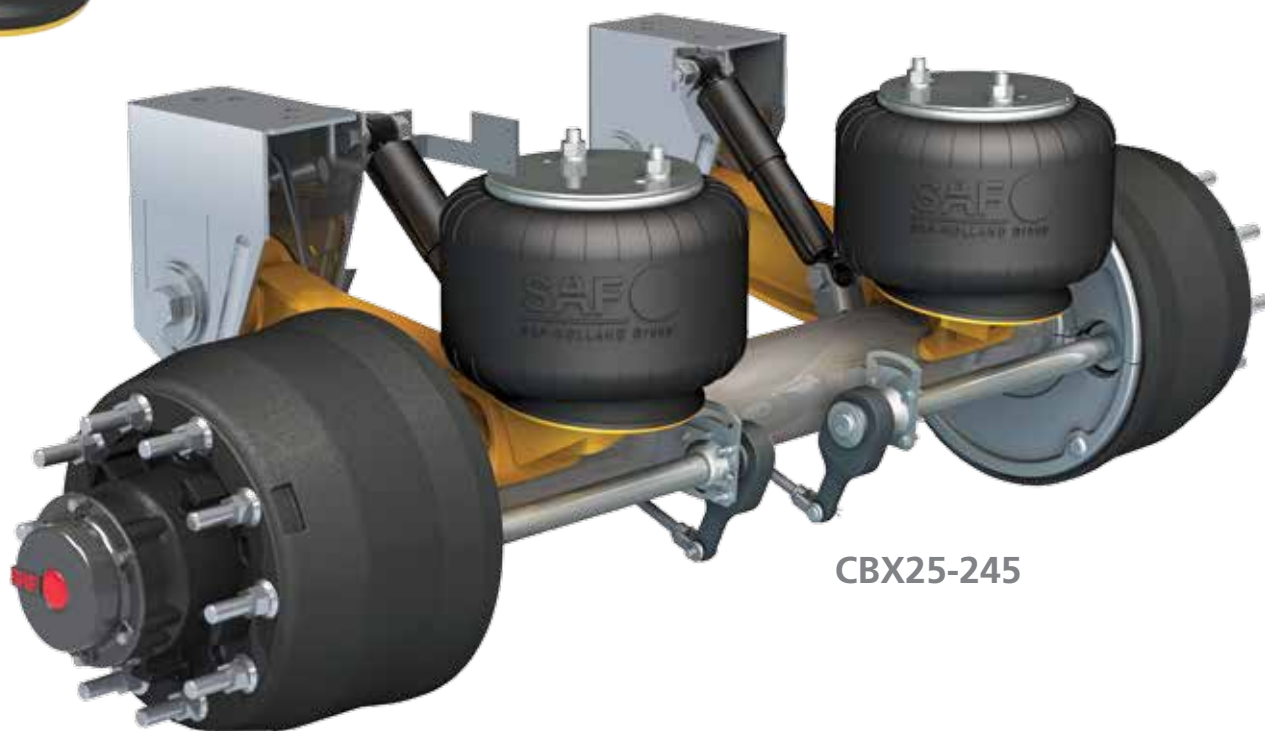

CBX25-245

When equipped with optional SAF INTEGRAL® disc brakes, the CBX25 is the lightest weight 11,340 kg disc brake suspension available.

SUSPENSION SYSTEM WEIGHTS	CBX25-245	CBX25-287
Drum Brake Axle System	450 kg	469 kg
Disc Brake Axle System	387 kg	406 kg

POSILIFT™

OPTIONAL LIFT AXLE SYSTEM

Light, durable and easy to install, SAF's PosiLift Axle Lift System allows operators to easily increase payload with just the flip of a switch. In addition to increased payload capacity, liftable axles also provide an opportunity to extend tire life, improve operational versatility and fuel efficiency, as well as enhancing trailer maneuverability.

POSILIFT™ FEATURES

- Compact Design
- Simple Under Axle Lift
- Easy to Install or Retrofit



Designed with simplicity and durability in mind.
PosiLift™ is light, simple to install, and easy to maintain.

SPECIFICATIONS

CBX25

FEATURES	STANDARD	OPTIONS
Ride Heights	385 - 445 mm	Upon Request
Swing Align™	•	
Air Springs with 1/4" Ports	•	
PosiLift™ Lightweight Lift Axle System		•

STANDARD DRUM BRAKE AXLE PACKAGE

Axle Diameter	146 mm	NA
Axle Track	1830 mm	2040 mm
Spindle	Parallel	
Drum Brake	419 x 203	NA
Tire Inflation Prep: Drilled & Tapped Only		•
Dust Shields	•	
Fully Dressed with ASB Sensors		•

OPTIONAL INTEGRAL® DISC BRAKE

Axle diameter	146 mm	NA
Axle Track	1830 mm	2040 mm
Fully Dressed with ASB Sensors	•	NA
Dust Shields	•	
Tire Inflation Prep: MTIS (Stator Pipe & Freeze Plugs)		•

* Other axle tracks available upon request.





SAF-HOLLAND is a leading supplier of highly efficient components, systems and service programs in the global commercial vehicle industry. Our three core product brands are recognized for delivering innovative solutions that optimize fleet operations in every corner of the world.



**TRAILER AXLES AND
SUSPENSION SYSTEMS**



**COUPLING AND LIFTING
TECHNOLOGIES**



**SUSPENSIONS FOR
TRUCKS AND BUSES**

With our team of over 3,000 employees and a worldwide network of over 9,000 service partners, we serve our fleet customers with know-how and passion, and always focused on one target: **Engineering your road to success.** Anywhere in the world. Under any conditions. 365 days a year.

HIGHLY EFFICIENT COMPONENTS AND SYSTEMS FOR TRUCKS AND TRAILERS



EUROPE | AMERICAS | AFRICA | ASIA | MIDDLE EAST | AUSTRALIA

safholland.com.br

SAF-HOLLAND do Brasil

Av. Emílio Marconato, 1000

Galpão B-16, Chácara Primavera

13.820-000 Jaguariúna - SP

Tel. + 55 19 3311-1572 · Fax + 55 19 3311-1554

vendas@safholland.com.br