

**SAF CBX46 SERIES**  
SUSPENSION SLIDER AXLE SYSTEM



OPTIONAL  
**P89** Series  
™ AIR DISC BRAKES

THE EXTRA CAPACITY TANDEM SLIDER  
SOLUTION FOR ON/OFF HIGHWAY VAN  
AND REEFER TRAILERS

# SAF CBX46 AIR SUSPENSION SLIDER AXLE SYSTEM

## OPTIONAL UPPER BODY RAILS

Roll formed body rails are manufactured from high strength 80,000 KSI steel.



## ROBUST SLIDER SUB-FRAME

Constructed with 80 KSI yield material and designed with two additional crossmembers, the CBX46 is the most robust and structurally rigid 46K slider on the market.

46,000 lbs.  
CAPACITY

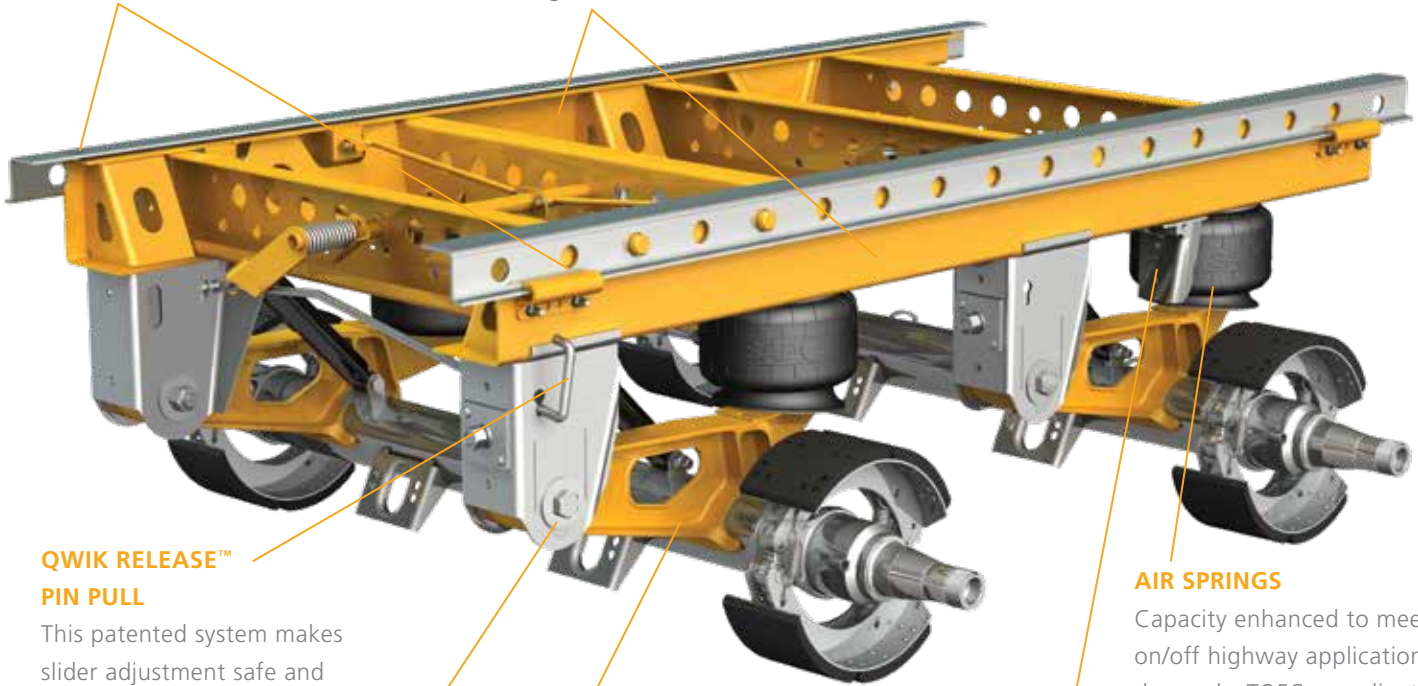

## QWIK RELEASE™ PIN PULL

This patented system makes slider adjustment safe and efficient. With 20% less pulling effort than competitive models – one person can easily reposition the slider. This design also alleviates bound-up pin problems.

## SWING ALIGN™

The fastest and most convenient axle alignment system in the industry. No replacement parts or disassembly is required. Axle alignment adjustment is made directly by the lead screw. Requires less than 250 ft. lbs. of torque to adjust.

## MULTI-FUNCTIONAL PIVOT BUSHING

The more robust bushing with its exterior void design limits the twisting movement that could lead to premature bushing and tire wear.

## LIGHTWEIGHT CAST STEEL TRAILING ARM DESIGN

Rated for 23,000 lb. capacity per axle for carrying heavier loads, the CBX46 is designed with our proven air suspension trailing arm thin-wall casting technology.

## AIR SPRINGS

Capacity enhanced to meet on/off highway application demands. TOFC compliant with a standard pneumatic dump valve.

## POSILOK™

Eliminates dock walk and squat. Creates a stable and safe loading and unloading operation.

## DRUM BRAKE AXLE IS STANDARD EQUIPMENT

The SAF CBX46 standard configuration features a SAF X-Series 5.75" diameter axle with 16½" x 7" extended life brake linings, intermediate cams, and industry standard tapered or parallel spindles.



LEARN MORE ABOUT SWING ALIGN™

# THE LIGHTWEIGHT SLIDER SYSTEM FOR ON/OFF HIGHWAY TRAILERS



## OPTIONAL AIR RELEASE

is a simple, efficient pin-pull system. The Air Release design is compact, durable, and allows easy manual operation in the event of an air-down situation.



## OPTIONAL **P89** Series AIR DISC BRAKES

### TWO MODEL CHOICES TO MEET YOUR FLEET'S SPECIFIC NEEDS

The P89 model at a price point that makes sense for fleets of any size. And, the P89 Plus for premium performance. Disc brakes simply provide better performance than drum brakes. They stop shorter for increased safety and reduce maintenance for lower total cost of ownership.



**SPEC THE AUTO-POSILIFT™ SYSTEM –  
TESTED AND PROVED TO PROVIDE UP  
TO A 1% FUEL SAVINGS!\*\*\***



PATENT NUMBER – US 8,695,998 B1

*The patented Auto-PosiLift™ feature automatically lifts the front axle when the system senses that only one axle is necessary to carry the load.*

### SIGNIFICANT BOTTOM LINE BENEFITS

- Increased fuel mileage
- Increased tire life and reduced tire scrub
- No driver interaction required
- Reduction in toll fees
- Increased suspension component life
- Longer wheel end service intervals



LEARN MORE  
ABOUT  
AUTO-POSILIFT™

Reference XL-AS20008SL Auto PosiLift



**BLACK ARMOUR™  
IS STANDARD  
WITH CBX46**

LEARN MORE ABOUT  
BLACK ARMOUR™



SUSPENSION SYSTEM WEIGHTS	4650
Undressed Drum Brake Axle (16.5" x 7" braked axle only – no slack adjusters or brake actuators)	1,424 lbs.
Dressed Drum Brake Axle (Includes steel hubs/drums, bearings, oil, slack adjusters and brake actuators)	2,194 lbs.*
SAF P89 Series Air Disc Brake Axle	2,124 lbs.**

\* Optional lightweight dressed drum brake wheel ends available – 130 lbs. lighter.

\*\* Optional lightweight ADI disc brake hubs available – 132 lbs. lighter.

# OPTIONAL P89 SERIES AIR DISC BRAKES

## PROVEN DESIGN QUALITY WITH GENUINE VALUE

All the Benefits You Expect From the World's Leading Trailer Axle Disc Brake Supplier, at a Price Point That Makes Sense for Commercial Fleets of All Sizes

### Featuring

- Heavy-Duty Vented Rotor
- SAF Caliper
- Premium Matched Set Bearings
- Parallel or Taper Spindle
- 5-Year Warranty



## PREMIUM PERFORMANCE MAINTENANCE FREE DESIGN

Featuring the Legendary INTEGRAL® Rotor/Hub and Premium Sealed Bearings for Reduced Maintenance

### Featuring

- INTEGRAL® Rotor
- Long-Life Sealed Bearings
- Premium Brake Chambers
- SAF Caliper
- Robust Parallel Spindle
- Premium Spindle Nuts
- 7-Year Warranty



LEARN MORE  
ABOUT THE P89

**INDUSTRY LEADING AIR  
DISC BRAKE WARRANTY**

See XL-AS11002WC warranty statement for complete details.

**SAF**   
SAF-HOLLAND Group

# SPECIFICATIONS

## CBX46

FEATURES	STANDARD	OPTIONS
Ride Heights	16", 16½" & 17"	NA
Slider Width	48"	42" & 54"
Patented Qwik Release® Pull Arm	•	
Air Release		•
Swing Align	•	
Assembled System	•	
Height Control Valve with Dump	•	
Height Control Valve without Dump		•
Air Springs w/1/4" Ports	•	
PosiLok™ – Anti Dock Walk Device	•	
Slider Configured to Accommodate 6" Center 1-3/8" Body Rails	•	
Slider Configured to Accommodate 4" Center 1-5/8" Body Rails		•
Air Tank, Mud Flap & Stinger Brackets		•
Holland Slider Rails		•
Manual Stop Bars		•

## STANDARD DRUM BRAKE AXLE PACKAGE

Axle Diameter	5.75"	NA
Axle Track	77½"	71½", 81½", 83½"*
Spindle	Tapered	Parallel
Drum Brake	16½" x 7"	16½" x 8⅝"
Extended Life Linings	SAF Standard 20k	SAF Standard 23k
Tire Inflation Prep: Drilled & Tapped Only		•
MTIS (Stator Pipe & Freeze Plugs)		•
Cam Enclosures		•
Dust Shields		•
3 Pc. Spindle Nuts		•
Fully Dressed with ABS Sensors		•

## OPTIONAL P89 SERIES AIR DISC BRAKE AXLE PACKAGE

Axle Track	77½"	71½", 81½", 83½" *
P89 (5 Year System)	•	
P89 Plus (7 Year System)	•	
Spindle – New P89	Parallel	Taper
Spindle – P89 Plus	Parallel	NA
Fully Dressed with ABS Sensors Installed	•	NA
Dust Shields		•
Tire Inflation Prep: Drilled & Tapped Only		•
MTIS, Aeris or other commercially available systems		•

\* Other axle tracks available upon request.



Engineering Your Road to Success

**SAF-HOLLAND** is a leading supplier of highly efficient components, systems and service programs in the global commercial vehicle industry. Our three core product brands are recognized for delivering innovative solutions that optimize fleet operations in every corner of the world.



**TRAILER AXLES AND  
SUSPENSION SYSTEMS**



**COUPLING AND LIFTING  
TECHNOLOGIES**



**SUSPENSIONS FOR  
TRUCKS AND BUSES**

With our team of over 3,000 employees and a worldwide network of over 9,000 service partners, we serve our fleet customers with know-how and passion, and always focused on one target: **Engineering your road to success.** Anywhere in the world. Under any conditions. 365 days a year.

HIGHLY EFFICIENT COMPONENTS AND SYSTEMS FOR TRUCKS AND TRAILERS



EUROPE | AMERICAS | AFRICA | ASIA | MIDDLE EAST | AUSTRALIA

[safholland.com](http://safholland.com)

**SAF-HOLLAND, Inc.**  
888.396.6501 Fax 800.356.3929

**SAF-HOLLAND Canada Limited**  
519.537.3494 Fax 800.565.7753  
Western Canada 604.574.7491 Fax 604.574.0244