

# Repair Procedure

## Trailer Air Suspensions

### Trailer Air Suspension

#### Shock Bracket Replacement

## Introduction

This manual provides the information necessary for the replacement of the shock brackets on SAF® CB/CBX Underslung Suspension models.

**NOTE:** SAF® Service Manual for Trailer Air Suspensions, XL-AS20010MM-en-US MUST be obtained prior to making the repair.

The Service Manual for Trailer Air Suspensions contains information about removal, installation and verification that the unit can be returned to service which is needed throughout the following procedures. The service manual is available on the internet at [www.safholland.us](http://www.safholland.us) or by contacting Customer Service at 888-396-6501.

When replacement parts are required, use only SAF-HOLLAND® Original Parts. A list of technical support locations that supply SAF-HOLLAND® Original Parts and an Aftermarket Parts Catalog are available on the internet at [www.safholland.us](http://www.safholland.us) or contact Customer Service at 888-396-6501.

## Notes, Cautions, and Warnings

Before starting any work on the unit, read and understand all the safety procedures presented in this manual. This manual contains the terms "NOTE", "IMPORTANT", "CAUTION", and "WARNING" followed by important product information. These terms are defined as follows:

**NOTE:** Includes additional information to enable accurate and easy performance of procedures.

**IMPORTANT:** Includes additional information that if not followed could lead to hindered product performance.

**CAUTION** Used without the safety alert symbol, indicates a potentially hazardous situation which, if not avoided, could result in property damage.

**CAUTION** Indicates a potentially hazardous situation which, if not avoided, could result in minor or moderate injury.

**WARNING** Indicates a potentially hazardous situation which, if not avoided, could result in death or serious injury.

## 1. General Safety Instructions

- Read and observe all Warning and Caution hazard alert messages. The alerts provide information that can help prevent serious personal injury, damage to components, or both.

**WARNING** Failure to follow the instructions and safety precautions in this manual could result in improper servicing or operation leading to component failure which, if not avoided, could result in death or serious injury.

- All maintenance should be performed by a properly trained technician using proper/special tools, and safe procedures.

**NOTE:** In the United States, workshop safety requirements are defined by federal and/or state Occupational Safety and Health Act (OSHA). Equivalent laws may exist in other countries. This manual is written based on the assumption that OSHA or other applicable employee safety regulations are followed by the location where work is performed.

- After re-positioning the brake chamber, slack adjuster and/or ABS system as instructed in this manual, ALWAYS consult the manufacturer's manual for proper operation.

**IMPORTANT:** Key components on each axle system including but not limited to suspension, slack adjuster, brake chambers, bearings, hubs, and drums require information supplied by the original manufacturer of the components to ensure proper and safe operation of the axle system.

**WARNING** Failure to follow the original manufacturer's instructions regarding spring brake or air pressure control may allow an uncontrolled release of energy which could result in death or serious injury.

- Service both roadside and curbside of an axle. Worn parts should be replaced in sets. Key components on each axle's braking system, such as friction material, rotors and drums will normally wear over time.
- The wheel contact surfaces between the wheel and hub MUST NOT receive additional paint.

## 2. Allowable Suspension Repairs

This SAF® suspension repair is limited to the attachment welds or replacement of shock brackets on underslung axles where a shock bracket has been damaged. If any damage, including bending, dents or cracks, is evident on the SAF axle tube, DO NOT repair the axle. Remove and replace the entire axle.

**⚠ WARNING** Failure to replace a damaged SAF axle tube could result in reduced strength in the axle tube which, if not avoided, could result in death or serious injury.

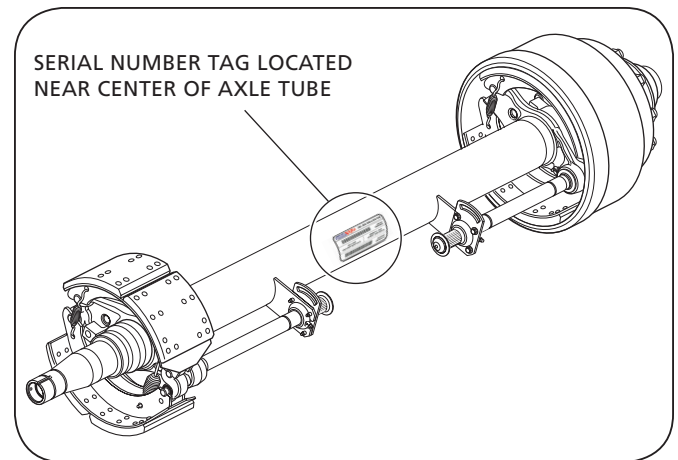
## 3. Model Identification

Service manuals and repair part information for the SAF® axle and suspension can be located by the suspension model number on the internet at [www.safholland.us](http://www.safholland.us).

The axle serial number tag is located near the center of the axle tube (**Figure 1**).

If the serial number tag cannot be located or repair and service information obtained from the internet, contact customer service at 888-396-6501.

**Figure 1**



### 4. Identification Tag

The sample tag shown will help interpret the information on the SAF-HOLLAND®, Inc. serial number tag. The tags, which may vary, contain the part number, axle beam rating, and serial number (*Figure 2*).

Record the tag numbers below for future quick reference.

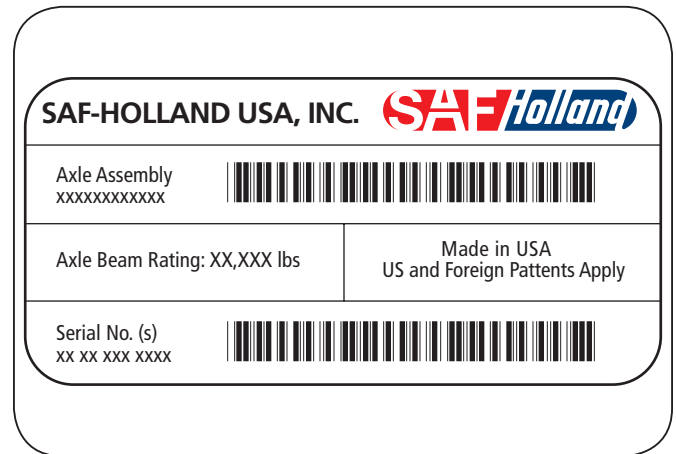
**Axle Number:** \_\_\_\_\_

**Axle Rating:** \_\_\_\_\_

**Serial Number:** \_\_\_\_\_

**In Service Date:** \_\_\_\_\_

*Figure 2*



## 5. Bracket Welding

### 5.1 Operator

Installation welding of replacement brackets is to be performed by welders who are certified in accordance with American Welding Society (AWS) D1.1.

### 5.2 Component Conditions

The axle and replacement bracket(s) must be at least 60° F (15° C) before any weld repair is performed.

The axle and replacement brackets **MUST** be clean and free from any paint, corrosion, moisture, oil, grease, or debris.

### 5.3 Weld Parameters

All SAF-HOLLAND® axle assembly repair welds are to be with AWS filler metal specification AWS A5.28, filler metal classification ER-90S-D2.

**NOTE:** Any substitutions for filler metals from the standard above must comply with the following mechanical properties, at a minimum:

Tensile Strength - 90 KSI (620 Mpa)  
Yield Strength - 78 KSI (540 Mpa)  
Charpy V notch - 20 ft/lbs (27 N•m) @ 0°F (-18°C)  
% Elongation - 17%

The recommended welding gas for gas metal arc welding (GMAW) is 90% Argon / 10% CO<sub>2</sub>.

### 5.4 Procedures

Tack welds used in positioning a shock bracket are to be located in the center area of the final weld where practical. The tack should be completely fused into the finished weld.

3/16" (5 mm) fillet welds are to be used in the attachment of shock brackets.

**IMPORTANT:** DO NOT break the arc at the end of the weld. Back up all finish welds at least 1/2" (12 mm), or a sufficient amount for the prevention of craters at the end of the weld.

No undercut is allowed on the axle tube.

The maximum depth of undercut on the shock bracket shall be no greater than 1/32" (0.8 mm).

**IMPORTANT:** DO NOT attach the welding ground cable such that wheel bearings are between the ground cable and the area to be welded. This will result in a large electrical current passing through the wheel bearings, potentially damaging them.



Failure to prevent damaging a wheel bearing by weld current could result in a wheel end failure which, if not avoided, could result in death or serious injury.

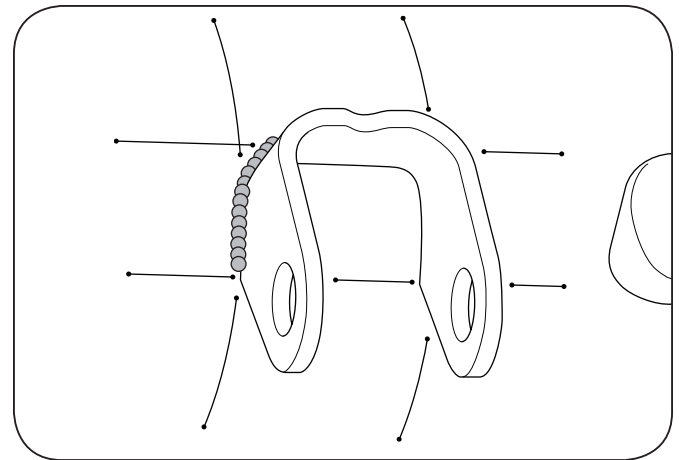
## 6. Shock Bracket Replacement

1. If needed, remove the axle from the trailer. Refer to the appropriate suspension model manual.
2. Remove the shock from the damaged bracket.
3. Using a straight edge and a permanent marker or scribe, mark the bracket location. Be careful when removing the bracket to avoid removing the location marks (**Figure 3**).
4. Remove the damaged shock bracket.
  - Minimize the heat introduced into the axle tube by cutting the bracket off as quickly as possible, at a distance of 1/4" (6 mm) to 1/2" (12 mm) from the axle tube (**Figure 4**).

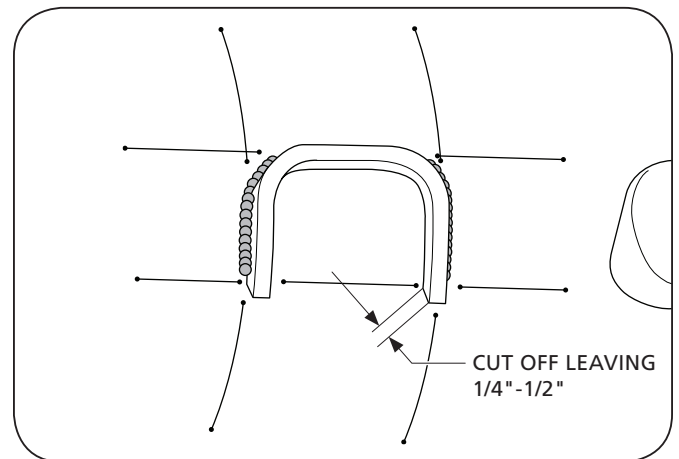
**⚠ WARNING** Failure to minimize the heat introduced into the axle tube or damaging the surface of the SAF® axle tube can reduce the strength of the axle, potentially causing an axle fracture which, if not avoided, could result in death or serious injury.

- When removing the damaged shock bracket, be careful not to cut or grind below the surface of the SAF® axle tube.
5. Being careful not to remove the location marks, grind away the remaining portion of the bracket (**Figure 5**).
  6. Using a straight edge and a permanent marker or scribe, draw lines to connect the previously made location marks from Step 3 (**Figure 6**).

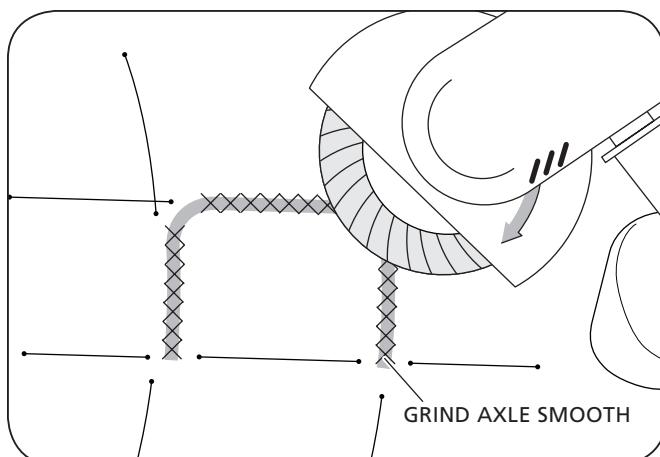
**Figure 3**



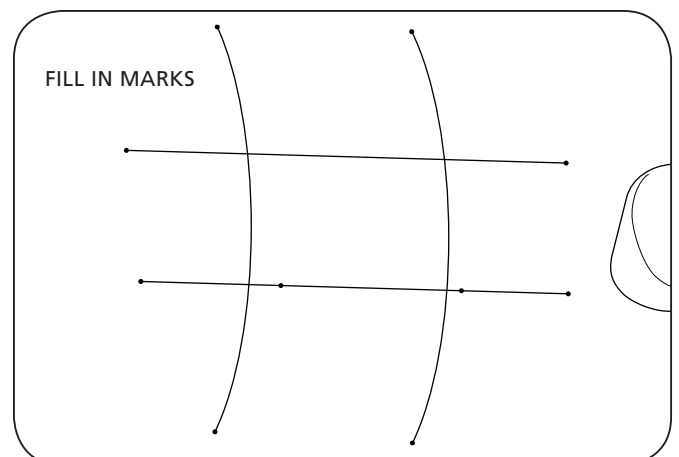
**Figure 4**



**Figure 5**

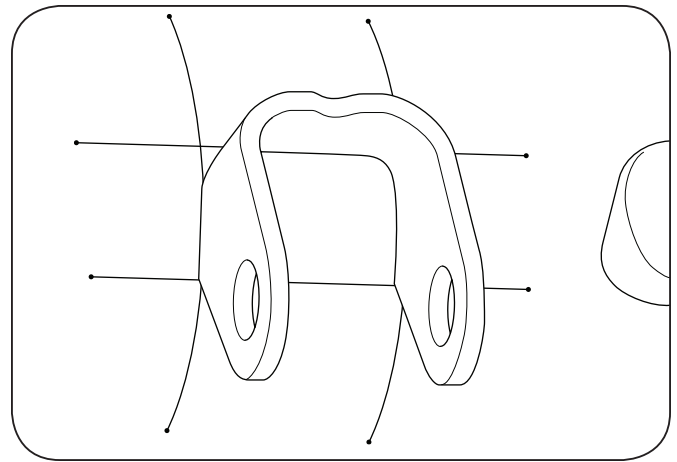


**Figure 6**

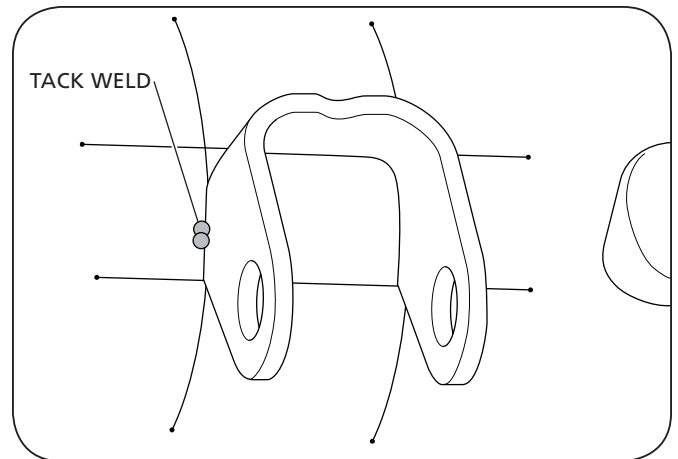


8. Place a new shock bracket on the axle in alignment with the location marks (**Figure 7**).
9. Make sure both the bracket and axle tube are clean and free from all moisture, scale, grease, and oil.
10. Tack weld the bracket to the axle tube on the outside of the two legs (**Figure 8**).
11. Verify that the shock bracket is aligned with the marks on the axle. If the brackets are not in alignment, remove the tack weld, re-position the bracket and re-tack weld.
12. Place a mark 1/8" (3 mm) in from the end of the shock bracket on both the inside and outside of both legs (**Figure 9**).
13. Weld the shock bracket with a 3/16" (5 mm) fillet weld on both the inside and outside of the bracket, refer to Welding Standards in Section 5. Make sure the welds stop at least 1/8" (3 mm) from the edge of the bracket, at the mark created in Step 12 (**Figure 10**).
14. Clean and paint/undercoat the welded area and any adjacent area where paint was removed to facilitate bracket replacement.
15. Re-install the shock, nut and bolt into the bracket, torque to 140-175 ft-lb. (190-237 N•m).
16. Re-install the axle in accordance with SAF® Service Manual for Trailer Air Suspensions, XL-AX20010MM-en-US.

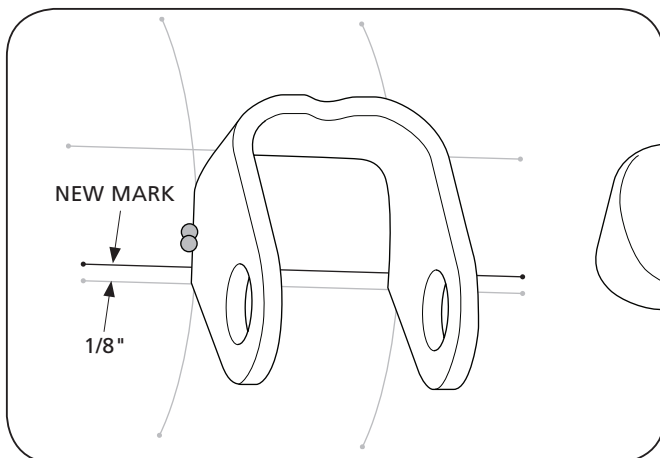
**Figure 7**



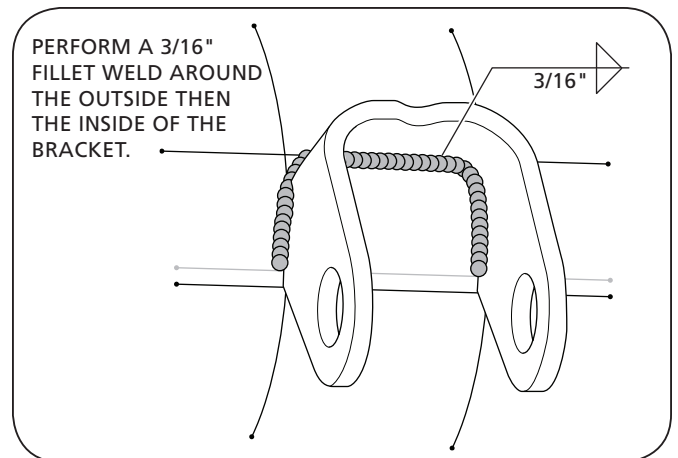
**Figure 8**



**Figure 9**



**Figure 10**







From fifth wheel rebuild kits to suspension bushing repair kits, SAF-HOLLAND Original Parts are the same quality components used in the original component assembly.

SAF-HOLLAND Original Parts are tested and designed to provide maximum performance and durability. Will-fits, look-alikes or, worse yet, counterfeit parts will only limit the performance potential and could possibly void SAF-HOLLAND's warranty. Always be sure to spec SAF-HOLLAND Original Parts when servicing your SAF-HOLLAND product.

**SAF-HOLLAND USA • 888.396.6501 • Fax 800.356.3929**  
[www.safholland.us](http://www.safholland.us)

**SAF-HOLLAND CANADA • 519.537.3494 • Fax 800.565.7753**  
**WESTERN CANADA • 604.574.7491 • Fax 604.574.0244**  
[www.safholland.ca](http://www.safholland.ca)

**SAF-HOLLAND MEXICO • 52.55.5362.8743 • Fax 52.55.5362.8743**  
[www.safholland.com.mx](http://www.safholland.com.mx)

[info@safholland.com](mailto:info@safholland.com)