



DB-1422

DB-1422 SPECIFICATIONS



Weight 11 lbs.



Cast steel drawbar with induction hardened wear area. 2.38" I.D. eye with 1.63" x 1.69" diameter section. To be used with channel, square or rectangular tube mounting configurations.

18,000 lbs. Maximum Vertical Load
90,000 lbs. Maximum Gross Trailer Weight

NOTE: When used for hinged tongue trailer applications where maximum vertical load cannot exceed 500 lbs., the maximum gross trailer weight is 120,000 lbs.

SAE J847 Information:

Type I - not applicable. Type II - 95,000 lbs.

IMPORTANT SAFETY INFORMATION

Maintain adequate vertical (tongue) load to adequately control the trailer (generally 10%), but do not exceed the capacity ratings at right.

This equipment must not be used or maintained in a careless manner.

When welding, use a procedure which assures a sound, good quality weld which protects the welding operator and others. Overwelding may cause distortion and damage. Underwelding may not develop sufficient strength. A low hydrogen process and AWS E70XX filler metal are recommended. Take precautions to insure that the vehicle electrical system is not damaged by the welding.

DURING OPERATION

1. Be sure the drawbar size is compatible with the coupling device on the tow vehicle.
2. Do not damage the coupling components. Be particularly careful during coupling and uncoupling.
3. Inspect the coupling device on the tow vehicle for proper operation. Do not use any coupling device that does not operate properly.
4. Other steps and inspections are also required. Consult OSHA and D.O.T. regulations and American Trucking Association for complete coupling and uncoupling procedures. These cover items such as cargo securement, brakes, lights, safety chains, and other important requirements.

GENERAL INFORMATION:

1. Do not modify or add to the product.
2. Wear safety goggles during installation and removal.
3. Never strike any part of the item with a steel hammer.
4. Do not weld on this product, other than as directed for installation, without written consent from the factory.

This product is covered by Holland's Commercial Products Warranty. Holland reserves the right, without giving prior notice, to change specifications and dimensions as designs are altered or improved.

TOWING APPLICATIONS:

Trailers, full trailers (including doubles) and equipment designed for over-the-road towing within the stated capacities. For off-road applications, reduce the above capacities by 25% and use in conjunction with a swivel type coupling device.

MOUNTING:

1. This drawbar is manufactured from hardened AISI steel and is intended for welded installation.
2. The mounting structure must be made from channel, rectangular or square tubing with angle spread of 30° (see drawing on the reverse) and have sufficient strength to support the rated capacity of the drawbar in accordance with SAE J849 and SAE J847, respectively.
3. To mount the drawbar weld the drawbar onto the mounting structure using a 3/8" (.38") weld at the prescribed locations (see drawing on the reverse) and a minimum weld length of 32 linear inches.

OPERATION AND MAINTENANCE:

Before operating, inspect for wear or damage and a secure mounting. If wear exceeds 1/8" (0.125") from the original surface profile, or if mounting is weakened, replace the drawbar.

DB-1422

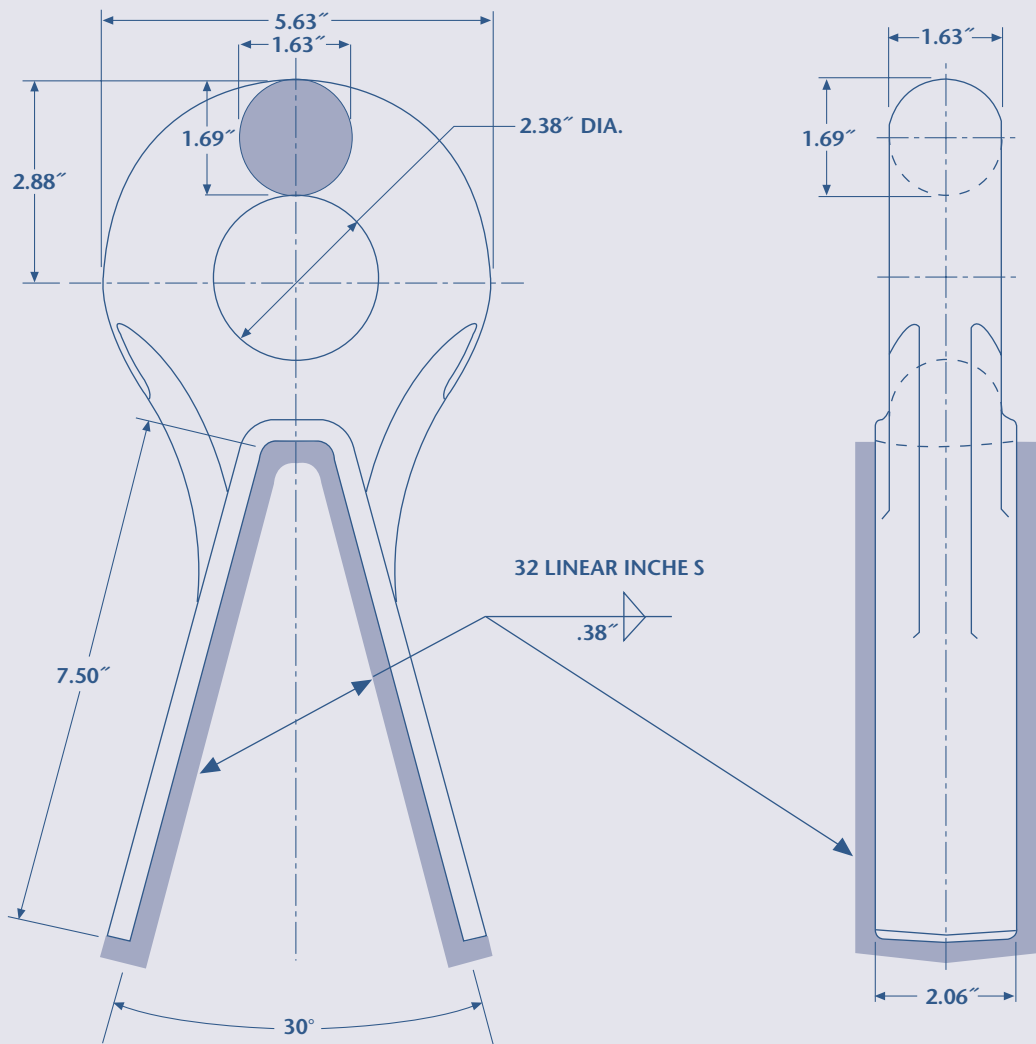

ALL DIMENSIONS SHOWN ARE NOMINAL

Copyright © April 2002 • The Holland Group, Inc.

Holland USA, Inc. Facilities:

Denmark, SC Muskegon, MI
 Dumas, AR Warrenton, MO
 Holland, MI Whitehouse Station, NJ
 Milpitas, CA Wylie, TX

Ph: 888-396-6501 Fax: 800-356-3929

Holland International, Inc.

Holland, MI
 Phone: 616-396-6501
 Fax: 616-396-1511

Holland Hitch of Canada, Ltd.

Woodstock, Ontario • Canada
 Phone: 519-537-3494
 Fax: 800-565-7753

Holland Equipment, Ltd.

Norwich, Ontario • Canada
 Phone: 519-863-3414
 Fax: 519-863-2398

Holland Hitch Western, Ltd.

Surrey, British Columbia • Canada
 Phone: 604-574-7491
 Fax: 604-574-0244