

Owner's Manual

Weld-on Forged Steel Drawbars

Installation, Operation and Maintenance Procedures

- Not for on/off-road or construction applications
- Designed for baggage and materials handling equipment
- Weight: DB-010EJ1 (approx.) 4.5 lbs. (2.04 kg)
DB-020FK1 (approx.) 8.5 lbs. (3.86 kg)



DB-010EJ1

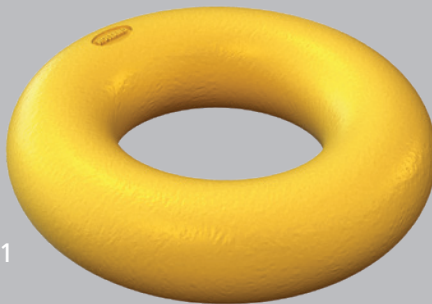

DB-020FK1

For Load Ratings, Refer to Section 4

Contents	Page
Introduction.....	2
Warranty.....	2
Notes, Cautions, and Warnings	2
Section 1 – General Safety Instructions	3
Section 2 – Welding Standards	4
Section 3 – Drawbar Eye Dimensions.....	6
Section 4 – Load Ratings.....	8

Contents	Page
Section 5 – Towing Applications	8
Section 6 – General Information	8
Section 7 – General Safety Information	8
Section 8 – Mounting Instruction	9
Section 9 – Operating Instructions	10
Section 10 – Maintenance.....	11

Introduction

This manual provides information necessary for the proper operation, maintenance, and inspection of the SAF-HOLLAND® drawbar.

NOTE: For HOLLAND® replacement components contact SAF-HOLLAND® Customer Service: 1-888-396-6501.

Warranty

Refer to the complete warranty for the country in which the product will be used. A copy of the written warranty can be downloaded from our SAF-HOLLAND® website (www.safholland.com).

Notes, Cautions, and Warnings

Read and understand all of the procedures presented in this manual before starting any work on the pintle hook.

NOTE: In the United States, work shop safety requirements are defined by federal and/or state Occupational Safety and Health Act. Equivalent laws could exist in other countries. This manual is written based on the assumption that OSHA or other applicable employee safety regulations are followed by the location where work is performed.

Proper tools **MUST** be used to perform the mounting and maintenance procedures described in this manual.

This manual contains the terms “NOTE”, “IMPORTANT”, “CAUTION”, and “WARNING” followed by important product information. These terms are defined as follows:

NOTE: Includes additional information to enable accurate and easy performance of procedures.

IMPORTANT: Includes additional information that if NOT followed could lead to hindered product performance.

CAUTION Used without the safety alert symbol, indicates a potentially hazardous situation which, if not avoided, could result in property damage.

CAUTION Indicates a potentially hazardous situation which, if not avoided, could result in minor or moderate injury.

WARNING Indicates a potentially hazardous situation which, if not avoided, could result in death or serious injury.

1. General Safety Instructions

IMPORTANT: Read this manual before using this product. Keep this manual in a safe location for future reference.

Read and observe all warning and caution hazard alert messages in this publication. The information provided can help prevent death, serious injury and/or damage to components.

WARNING Failure to follow the instructions and safety precautions in this manual can result in equipment failure which, if not avoided, could result in death or serious injury.

NOTE: In this manual, all descriptions of orientation are relative to the vehicle.

Orientation

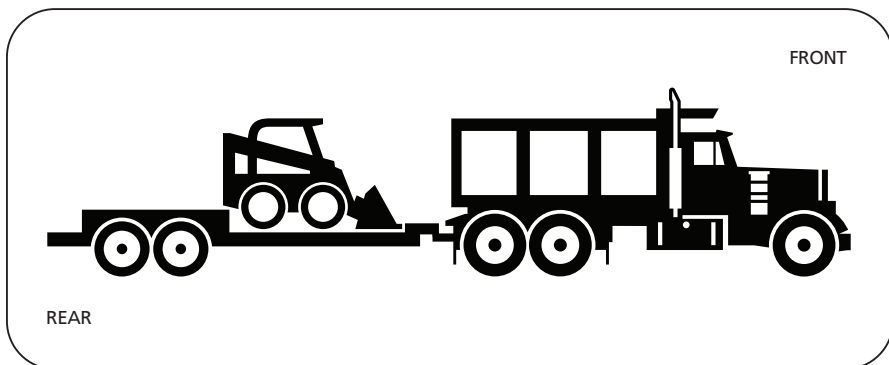

2. Welding Standards

2.1 Scope

When welding please observe the requirements below. Customers may NOT weld on SAF-HOLLAND® drawbars without prior approval, including the application of the American Welding Society standards by SAF-HOLLAND® unless required for installation. This specification applies to all components supplied by SAF-HOLLAND®, and its products. The customer assumes all responsibility for weld integrity if weld material and procedure differ from those listed below.

2.2 Material

The SAF-HOLLAND® drawbar has been manufactured from a modified AISI weldable grade steel, and is intended for welded installation with AWS filler metal specification AWS A5.18, filler metal classification ER-70S-3, ER-70S-6 or equivalent unless otherwise specified.

NOTE: Any substitution for filler material from the above standard MUST comply, as a minimum, with the following mechanical properties:

Tensile Strength - 72k psi (496 MPa)
Yield Strength - 60k psi (414 MPa)
Charpy V Notch - 20 ft.-lbs. (27 N•m)
at 0°F (-17.7°C)
% Elongation - 22%

The recommended welding gas for gas metal arc welding (GMAW) is 90% Argon/10% CO₂. If a different gas is used, welds MUST comply with penetration requirements as illustrated below. Where the installation directions specify different than above, the directions shall prevail.

2.3 Procedures

Tack welds used for positioning components are to be located in the center of the final weld, where practical. Tack weld should be completely fused to the finish weld. DO NOT break arc at the end of the weld. Back up all finish welds at least 1/2" (12 mm) of a sufficient amount to prevent craters at the end of the weld. Where weld is shown to go around corners, it is assumed the corner represents a stress concentration area. DO NOT start or stop weld within 1" (25 mm) of the corner. Particular care should be taken to prevent undercutting in this area.

Take precautions and ensure NOT to damage the vehicle electrical system during welding by disconnecting any power sources, properly grounding the vehicle, and shielding and exposed wiring.

2.4 Workmanship

It is the responsibility of the customer to provide good workmanship when attaching components with welds.

2.5 Weld Size

If weld size is NOT specified, the effective throat of the weld MUST be no smaller than the thinnest material being welded (**Figure 1**).

Figure 1

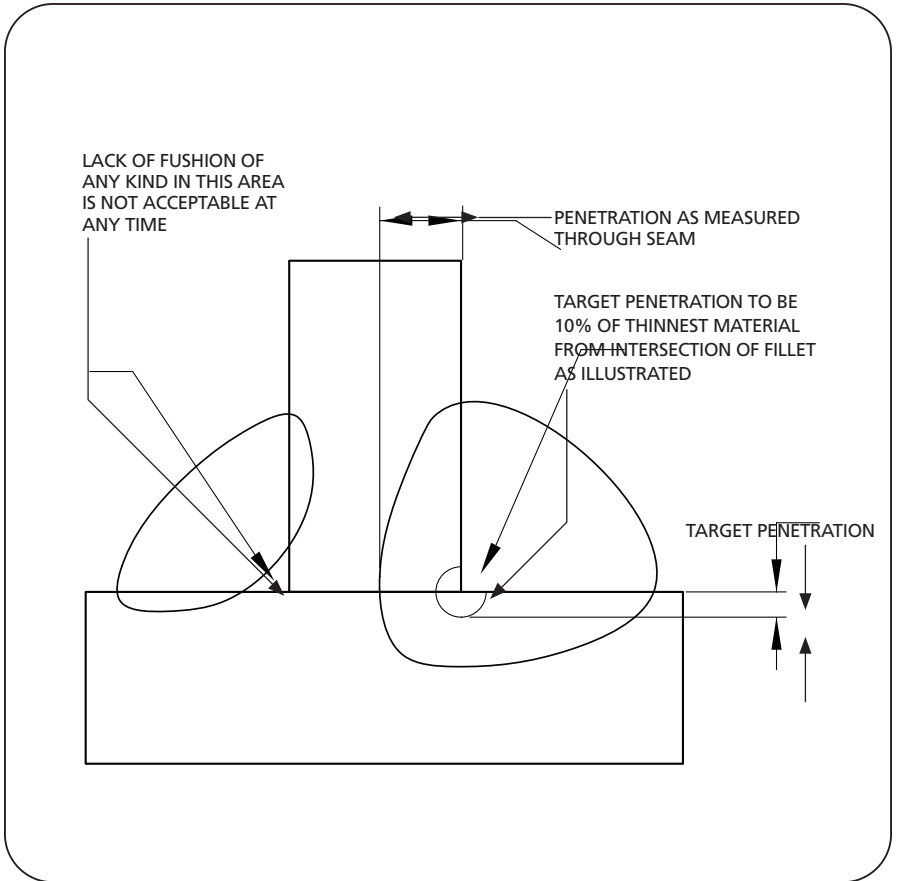

3. Drawbar Eye Dimensions

3.1 DB-010EJ1

2.9" (73.7 mm) I.D. with 1.0" (25.4 mm) diameter cross section.

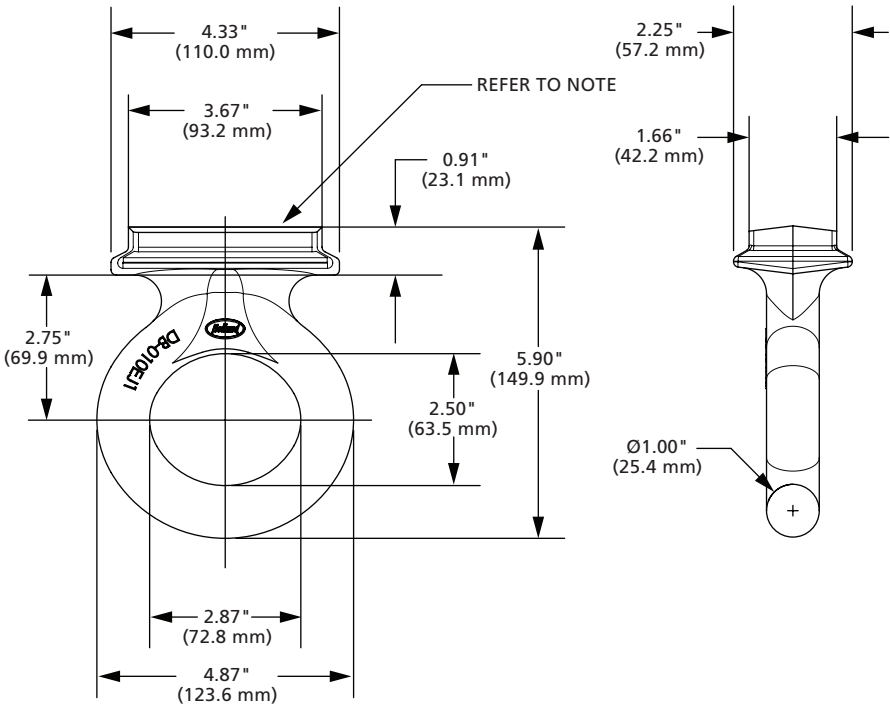

NOTE: 12.0" (304.8 mm) of linear weld 0.25" (6.35 mm) bevel groove weld on 2.0" (50.8 mm) x 4.0" (101.6 mm) 11 gage structural tubing required to obtain ratings.

3.1 DB-020FK1

3.0" (76.2 mm) I.D. with 1.63" (41.3 mm) diameter cross section.

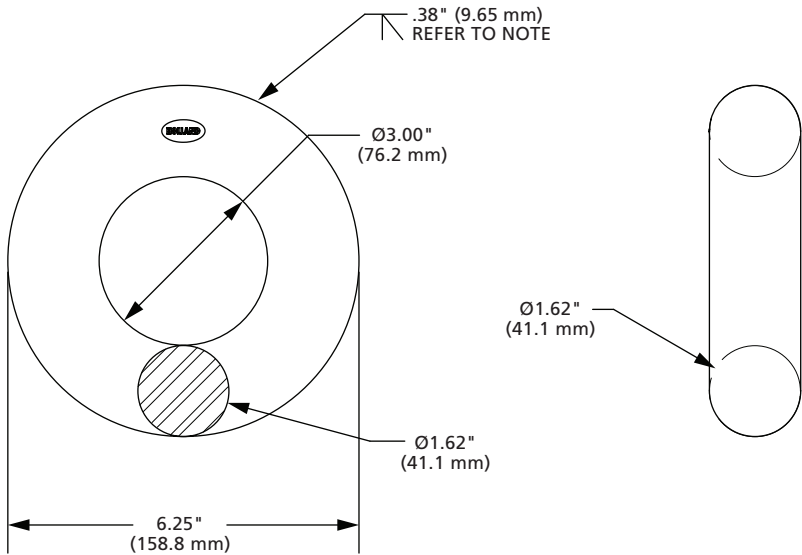

NOTE: 8.5" (215.9 mm) of linear weld 0.38" (9.53 mm) bevel groove weld (3.0" (76.2 mm) x 1.25" (31.75 mm) bar used) required to obtain ratings.

4. Load Ratings

4.1 DB-010EJ1

Maximum GTW: 10,000 lb. (4,536 kg)
Maximum Vert. Load: 2,000 lb. (907 kg)

Ratings are based on 12.0" (304.8 mm) linear inches of .38" (9.5 mm) bevel groove weld on 2.0" (50.8 mm) x 4.0" (101.6 mm) x 11 gauge structural tubing.

NOTE: When used for hinged tongue trailer applications
Max Vertical: 500 lb. (227 kg)
Max GTW: 20,000 lb. (9,072 kg)

4.2 DB-020FK1

Maximum GTW: 20,000 lb. (9,072 kg)
Maximum Vert. Load: 4,000 lb. (1,814 kg)

Ratings are based on 8.5" (215.9 mm) linear .38" (9.5 mm) bevel groove weld on 3.0" (76.2 mm) x 1.25" (31.8 mm) bar.

NOTE: When used for hinged tongue trailer applications:
Max Vertical: 500 lb. (227 kg)
Max GTW: 40,000 lb. (18,144 kg)

5. Towing Applications

This product is provided exclusively for airport ground support equipment and industrial material handling applications. This product has NOT been certified or tested for over the road use. Use only in non-highway towing applications.

IMPORTANT: Off-road refers to terrain on which a tow/towed vehicle will operate that is ungraded, rough or undulating, with no maintained travel surface, generally considered to NOT be part of the public road system. Examples include agricultural fields, construction sites, utility right-of-way, temporary logging roads, and what is commonly referred to as 'two-track' roads.

6. General Information

1. DO NOT modify or add to the product.
2. This product is covered by SAF-HOLLAND'S® Commercial Warranty. SAF-HOLLAND® reserves the right, without giving prior notice, to change specifications and dimensions as designs are altered or improved.
3. Inspect the coupling device on the tow vehicle and trailer for proper operation. DO NOT use any coupling device that DOES NOT operate properly.
4. It is the responsibility of the user to become familiar with coupling and uncoupling procedures that are provided by various governments, industry associations and mating component manufacturers instructions.

7. General Safety Information

This equipment MUST NOT be used in a careless manner.

During Operation:

1. Maintain adequate vertical (tongue) load to properly control the towed unit (generally 10% of maximum GTW) but DO NOT exceed the rated capacities.
2. DO NOT damage the coupling components. Be particularly careful during coupling and uncoupling.
3. NEVER strike any part of the item with a steel hammer.

8. Mounting Instructions

1. The mounting structure **MUST** be made from channel, rectangular, square, or solid bar; and have sufficient strength to support the rated capacity of the drawbar in accordance with SAE J849 and SAE J847 respectively.

NOTE: Welding to other structures may change the ratings of the drawbar.

- ⚠ WARNING** Failure to install in accordance with these instructions (using a certified welder) can result in trailer separation which, if not avoided, could result in death or serious injury.
2. Install the drawbar in compliance with all federal, state, or local agency regulations or laws governing the installation and use of the product. Consult with these agencies prior to installation or use.
 3. This drawbar is manufactured from modified AISI weldable grade steel, and is intended for welded installation.
 4. Take precautions to ensure **NOT** to damage the vehicle electrical system during welding by disconnecting any power sources, properly grounding the vehicle, and shielding and exposed wiring.
 5. Weld the drawbar onto the mounting structure using a appropriate bevel groove weld at the prescribed locations and a minimum weld length as specified for each drawbar (Refer to Section 3, page 6 for dimensions).

9. Operating Instructions

1. Before operating, inspect for wear, damaged areas and a secure mount. Correct as required before use.
2. Position the drawbar eye over the horn of the pintle and lower into place (**Figure 2 and 3**).
3. Engage the drawbar with the coupling device per the manufacturers instructions.

⚠ WARNING Failure to correctly secure the drawbar can result in separation of the pintle hook and drawbar which, if not avoided, could result in death or serious injury.

Figure 2

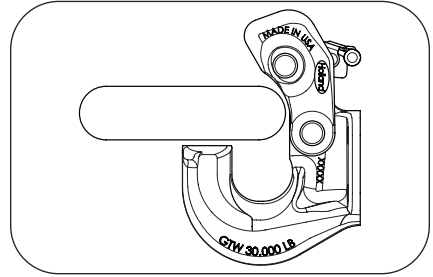
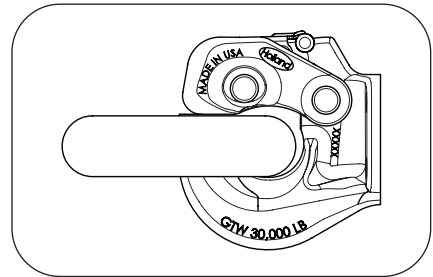

Figure 3



10. Maintenance

For proper performance, the following maintenance steps should be performed every 30,000 miles (48,280 km) or three (3) months, whichever comes first.

⚠ WARNING Failure to inspect and maintain the drawbar may result in separation of the pintle hook and drawbar, which, if not avoided, could result in death or serious injury.

1. Clean and check for wear, damaged, or missing parts, and a secure mount. Inspect for worn, damaged or missing parts. Replace as required using only Genuine SAF-HOLLAND® parts.
2. Inspect, in particular, the coupling contact area of the drawbar. Inspect for any nicks, gouges and deformation, which may interfere with or affect the safe use of the drawbar. If cracks are visible, replace.
3. Using calipers or the SAF-HOLLAND® drawbar gauges TF-11887, measure the cross section of the drawbar eye. Replace the complete product when wear exceeds 0.125" (3.18 mm) from the original surface profile. For original profile dimension (Refer to Section 3, page 6 for dimensions).
4. Inspect the drawbar mounting. For welded connections, inspect welds for soundness (Refer to Section 2). In addition to being a safety hazard, a loose drawbar will cause excessive "chucking" and rapid wear. Reinstall or replace any drawbar which is NOT securely mounted. Reinstall or replace any drawbar which is NOT securely mounted.



From fifth wheel rebuild kits to suspension bushing repair kits, SAF-HOLLAND Original Parts are the same quality components used in the original component assembly.

SAF-HOLLAND Original Parts are tested and designed to provide maximum performance and durability. Will-fits, look-alikes or, worse yet, counterfeit parts will only limit the performance potential and could possibly void SAF-HOLLAND's warranty. Always be sure to spec SAF-HOLLAND Original Parts when servicing your SAF-HOLLAND product.

SAF-HOLLAND USA • 888.396.6501 • Fax 800.356.3929
www.safholland.us

SAF-HOLLAND CANADA • 519.537.3494 • Fax 800.565.7753
WESTERN CANADA • 604.574.7491 • Fax 604.574.0244
www.safholland.ca

SAF-HOLLAND MEXICO • 52.1.55.5456.8641 • Fax 52.55.58162230
www.safholland.com.mx

info@safholland.com

SAF-HOLLAND USA, INC.
1950 Industrial Blvd., Muskegon, MI 49443
www.safholland.com

