



SAF-HOLLAND Group

# FW35 SERIES FIFTH WHEEL PARTS



## FW35 Series XA-351-A-L-P Std. Top Plate

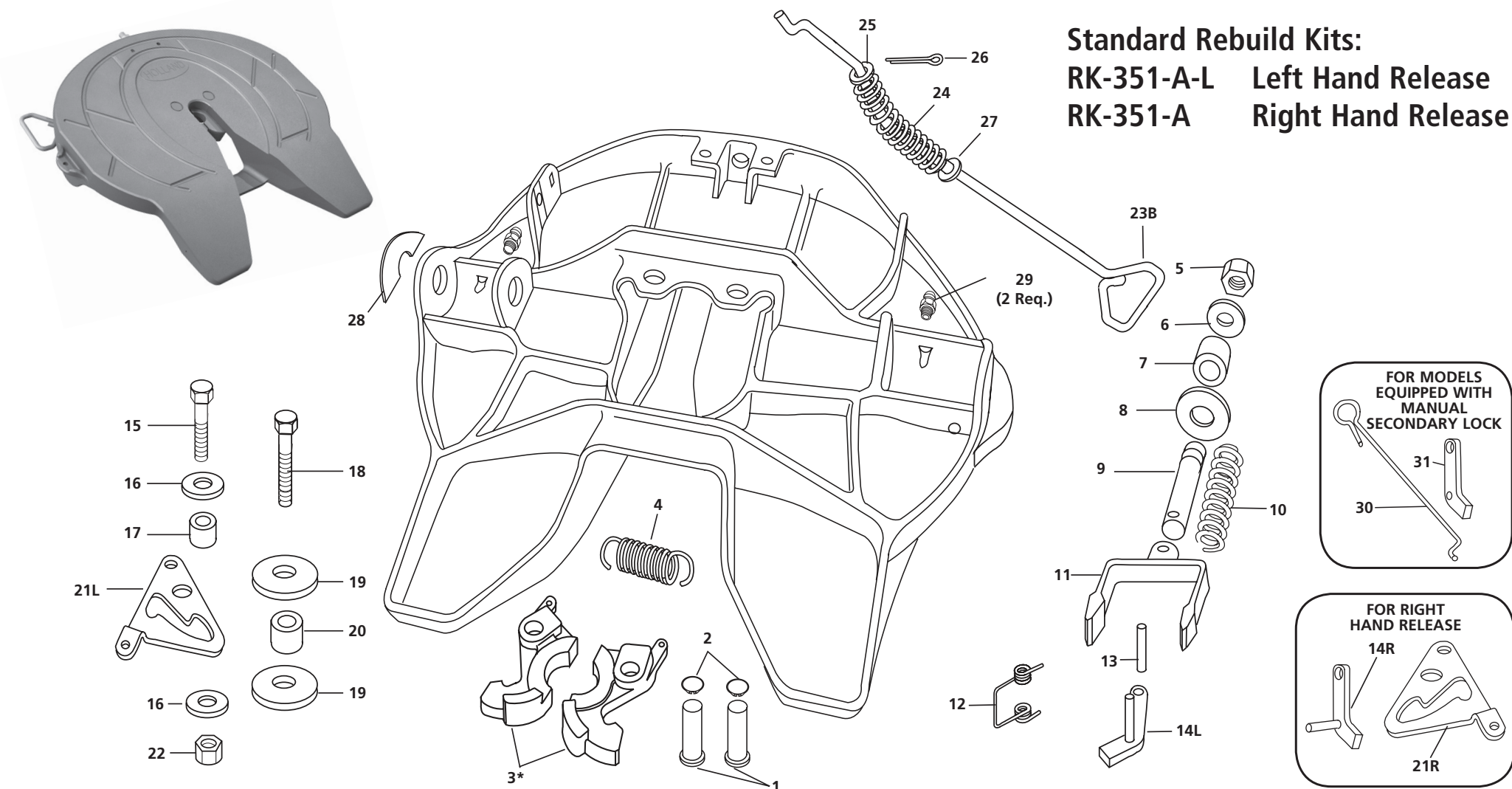

ITEM	DESCRIPTION	PART NO.	QTY.	ITEM	DESCRIPTION	PART NO.	QTY.
1	Lock Pin	XA-07292-1	2	26	Cotter Pin (.13" x 1.25")	XB-07508	1
2	Retaining Ring	XB-07398	2	27	Washer - 1.38" O.D. x .56" I.D.		
3	Lock Jaw Set (See Lock Replacement Kits RK-351-07296 & RK-351-07296-82)	XA-07296 *	1		-Manual Release	XB-T-49	1
4	Extension Spring	XB-07628	1		-Air Release	XB-T-49	2
5	Locknut (.75" -16)	XB-HNH-34-F	1	28	Operation Tag	XB-07610	1
6	Washer (1.5" O.D. x 1.18" I.D.)	XB-PW-1316-112	1	29	Grease Zerk	XB-H-38	2
7	Rubber Washer	XB-1127	1	30	Manual Secondary Lock Release Handle	XA-3542-M	1
8	Lock Adjustment Tag	XB-02312	1	31	Manual Secondary Lock	XA-3528	1
9	Yoke Shaft	XA-1706	1	32	Never Seez (not shown)	XB-02967	1
10	Compression Spring	XB-1505	1	33	Hex Head Cap Screw (.50"-20 x 1.25")	XB-C-95	2
11	Yoke	XA-07295	1	34	Bracket Pin	XE-06356	2
12	Torsion Spring	XB-2149	1	35	Air Release Cylinder Ass'y	XA-2524-R-16-L	1
13	Roll Pin (.50" x .75")	XB-21-5-500-2750	1	37	Cotter Pin .19" x 1.25"	XB-06336	1
14L	Secondary Lock Handle (left-hand)	XA-3542-L	1	61	Drive Screw 12" x .75"	XB-09155	1
14R	Secondary Lock Handle (right-hand)	XB-2149	1	62	Rubber Cushion	XB-0011-2	2
15	Hex Head Cap Screw (.50"-20 x 1.75")	XB-2083	1	74	Lock Replacement Kit (standad)	RK-351-07296	1
16	Washer (1.75" O.D. x .56" I.D.)	XB-08559	2	76	Bracket Pins & Bushing Kit	RK-06973-1	1
17	Roller (.50" I.D.)	XA-1029	1	77	Pocket Inserts Replacement	RK-PKT-2	1
18	Hex Head Cap Screw (.63"-18 x 1.75")	XB-CX-58-F-134	1	78	Bracket Pins & Cushions for ILS	RK-10605	1
19	Washer (2.63" x .66")	XB-07431	2	86	Air Release Retrofit Kit	RK-09649	1
20	Roller (.63" I.D.)	XA-1507	1	90	Air Release Rebuild Kit	RK-351-A-80-L	1
21A	Cam Plate (air release)	XA-1705	1	91	Cushion	XB-10605	4
21L	Cam Plate (left-hand)	XA-07150-L	1				
21R	Cam Plate (right-hand)	XA-07150-R	1				
22	Locknut (.50"-20 - for cam plate)		1				
	Locknut (.50"-20 - for bracket pins)	XB-T-69-A	2				
23A	Release Handle (air release - See Kit RK-07766-1)	XA-07766-1 *	1				
23B	Release Handle (universal for both left and right - See Kit RK-07151-1)	XA-07151-1 *	1				
23C	Release Handle (See drop release Retrofit Kit RK-08145-1) (not shown)	XA-08145-1 *	1				
23D	Release Handle (dolly - See Kit RK-351-09967) (not shown)	XA-09967 *	1				
24A	Spring (air release)	XB-07974	1				
24B	Spring (manual release)	XB-07291	1				
25	Washer (.69" O.D. x .50" I.D.)	XB-PW-1732-1-116	1				

\*Not for individual sale, order replacement kit.

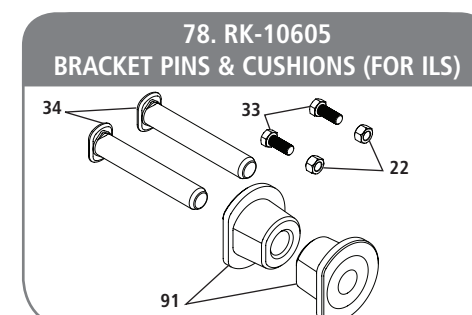
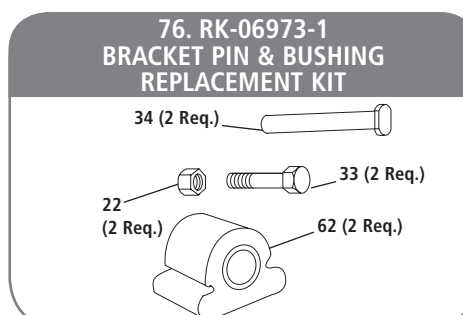
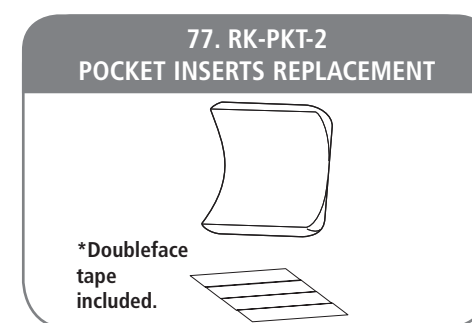
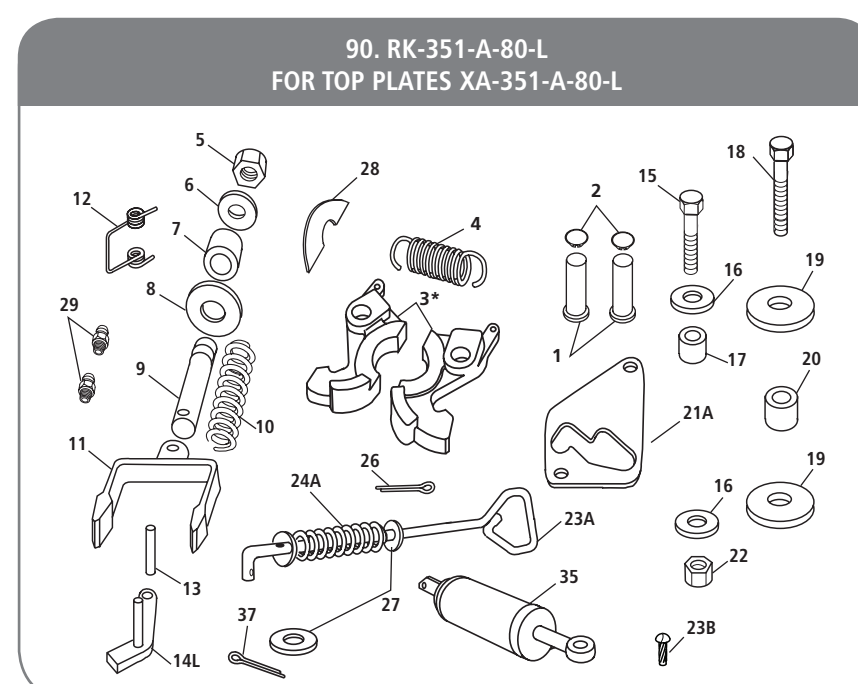
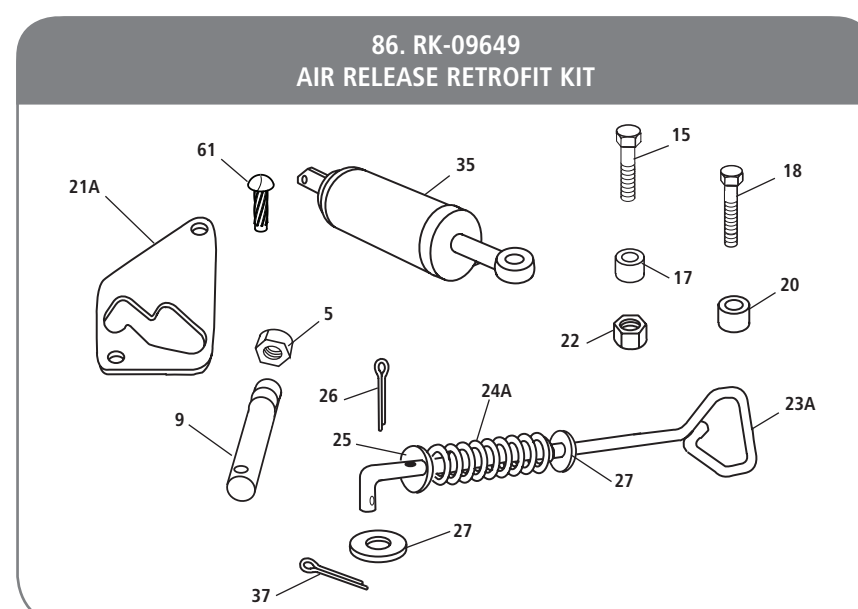

## FW35-03344 Stationary XA-351-03505-P Std. Top Plate

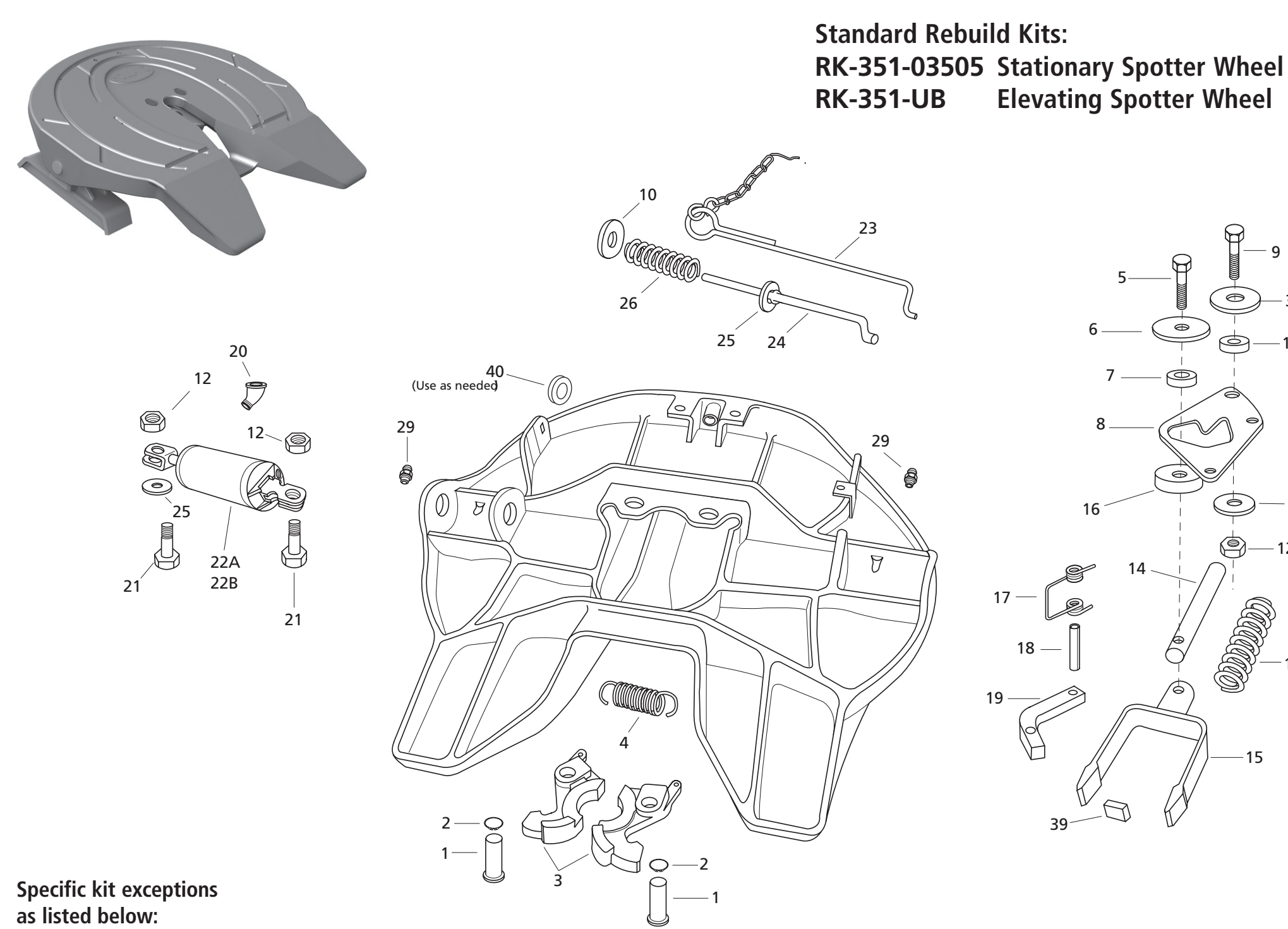

Standard Rebuild Kits:  
RK-351-A-L Left Hand Release  
RK-351-A Right Hand Release

Specific kit exceptions as listed below:  
• Parts included in RK-351-08332-1  
♦ Parts included in RK-09063  
\* See Air Cylinder Table below for proper air cylinder components.  
\*\* Included in RK-351-03505 ONLY.  
\*\*\* Not included in repair kits, except where noted.

ITEM	DESCRIPTION	PART NO.	QTY.	ITEM	DESCRIPTION	PART NO.	QTY.
1	Lock Pin	XA-07292-1	2	20	45° Street Elbow	XB-698	1
2	Retaining Ring	XB-07398	2	♦ 21	Screw .50"-20 x 1.75" LG.	XB-T-89-5	2
3	Lock Jaw Set	XA-08332-1	1	22A*	Air Cylinder	XA-2524-R-13-1	1
4	Extension Spring	XB-07628	1	22B*	Air Cylinder	XA-2524-R-13-4	1
5	Screw .63"-18 x 2"	XB-10035	1	23	Secondary Lock Handle	XA-3546	1
♦ 6	Washer .63" I.D. x 2.63" O.D. x .75" Thick	XB-07431	1	♦ 24	Release Handle	XA-09041	1
♦ 7	Roller .63" I.D.	XA-1507-1	1	♦ 25	Washer .50" I.D. x 1" O.D.	XB-PW-1732-1-116	2
♦ 8	Cam plate	XA-08988	1	♦ 26	Compression Spring	XB-07291	1
9	Screw .50"-20 x 1.75"	XB-2083	1	27**	Bracket Bearing	XA-03423	2
♦ 10	Washer .50" I.D. x 1.75" O.D.	XB-08559	2	28**	Bearing Stop Block	XA-0268	4
11	Roller .50" ID	XA-1029	1	29	Grease Fitting	XB-H-38	2
♦ 12	Locknut .50"-20 (2 add'l req. for brackets)	XB-T-69-A	3	30***	Bracket Pin	XA-2016	2
13	Yoke Spring	XB-1505	1	31****	Roll Pin .63" x 1.75"	XB-21-5-375-1750	2
♦ 14	Yoke Shaft	XA-1706-1	1	32****	Rubber Bushing	XB-0011	2
15	Yoke	XA-07295	1	35****	Screw 1.13"-7 x 7"	XB-BR-118-C-7	2
♦ 16	Cam Spacer	XA-09040	1	36****	Washer, Lock 1.13"	XB-E-536	2
17	Torsion Spring	XB-2149	1	37****	Rubber Bushing	XB-1604-5	2
18	Roll Pin .50" x 2.75"	XB-21-5-500-2750	1	♦ 38	Washer .50" I.D. x 2.25" O.D.	XB-1030	1
19	Secondary Lock	XA-3528	1	♦ 39	Yoke Stop	XA-09043	1
				♦ 40	Handle Guide	XA-09039	1
				♦ 41	Never-Seez (not shown)	XB-02967	1

AIR CYLINDER TABLE	
TOP PLATE ASSEMBLY	AIR CYLINDER COMPONENTS
XA-351-03505	Items 20 and 22A
XA-351-03505-2	Items 20 and 22A
XA-351-03505-3	Item 22B, omit Item 20
XA-351-03505-4	Items 20 and 22B
XA-351-UB	Items 20 and 22A

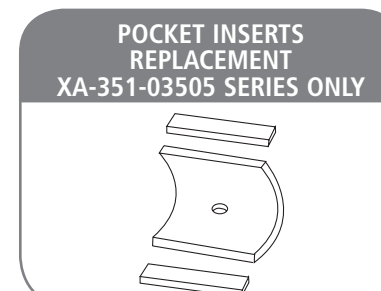
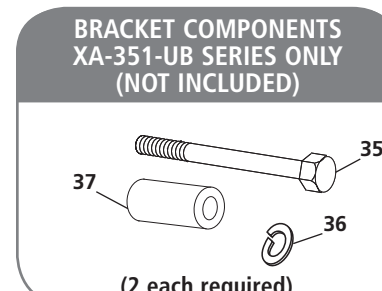
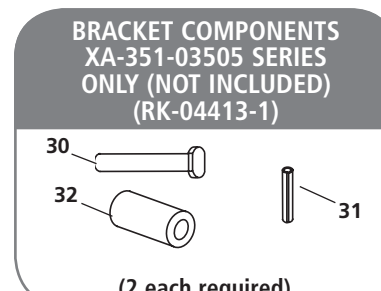

## FW67/68/69 Elevating XA-351-UB-P Std. Top Plate

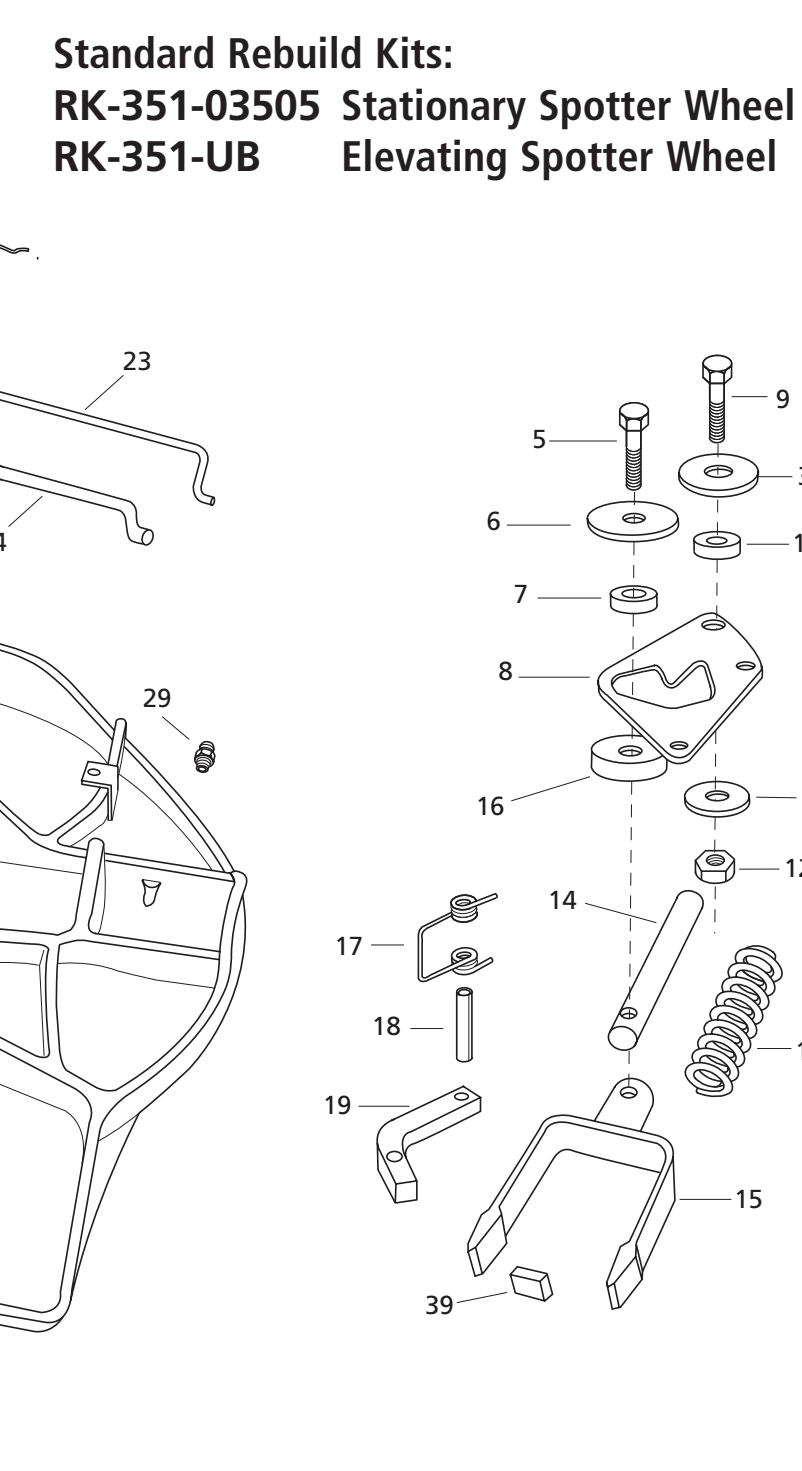

Standard Rebuild Kits:  
RK-351-03505 Stationary Spotter Wheel  
RK-351-UB Elevating Spotter Wheel

## FW3500 Series - Prior to 6/1/1996

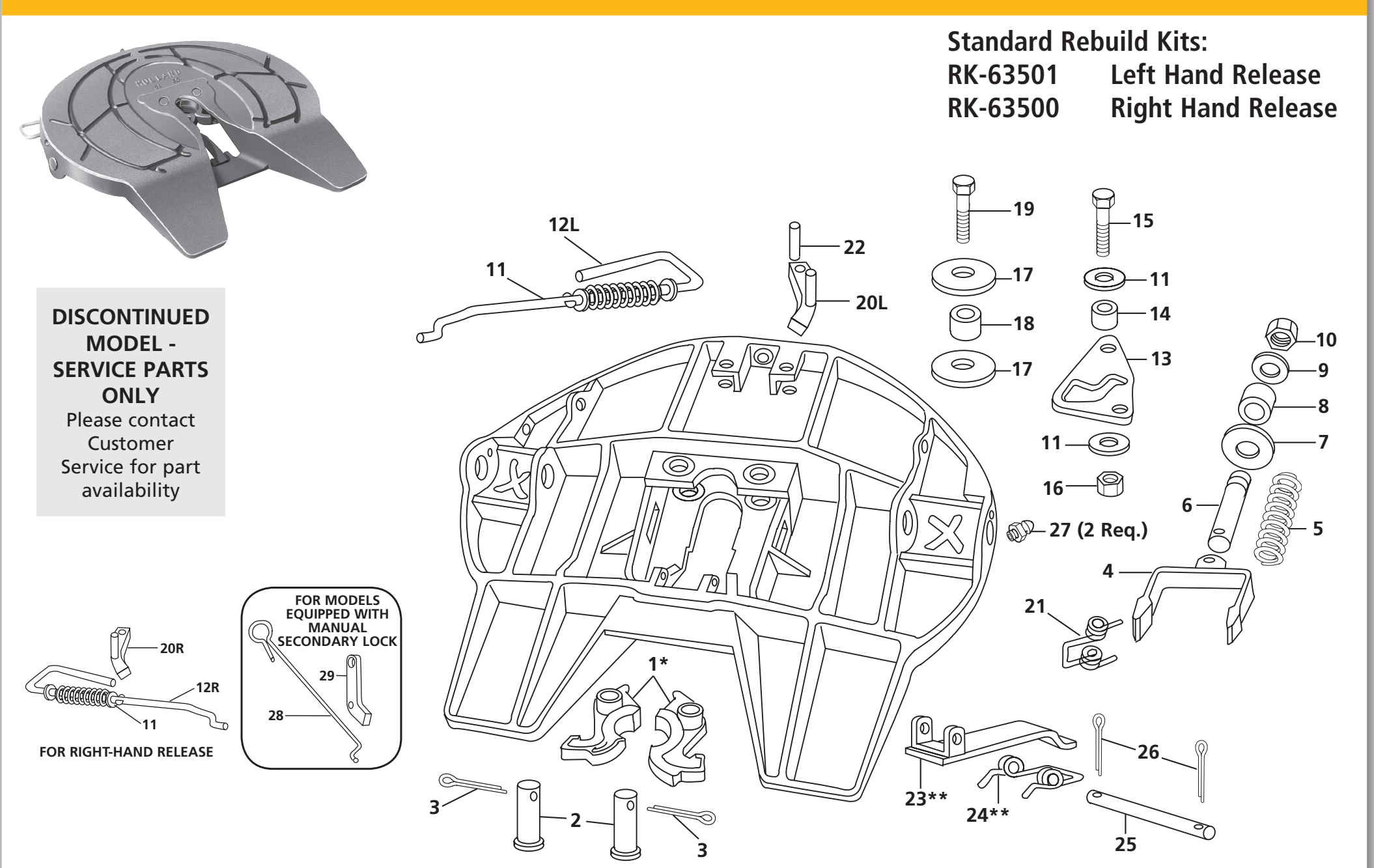

DISCONTINUED MODEL - SERVICE PARTS ONLY  
Please contact Customer Service for part availability

ITEM	DESCRIPTION	PART NO.	QTY.	ITEM	DESCRIPTION	PART NO.	QTY.
1	Lock Jaws	XA-1704*	1	17	Washer	XB-1030-1	2
2	Lock Pin	XA-1313	2	18	Roller	XA-1507	1
3	Cotter Pin .25" x 2"	XB-5	2	19	Bolt .63"-18 x 1.75"	XB-CX-58-F-134	1
4	Yoke Sub-Assembly	XA-1703-F	1	20L	Secondary Lock, Left-Hand	XA-3542-L	1
5	Spring	XB-1505	1	20R	Secondary Lock, Right-Hand	XA-3542-R	1
6	Yoke Shaft	XA-1706	1	21	Torsion Spring	XB-2149	1
7	Lock Adjustment Tag	XB-02312	1	22	Roll Pin	XB-21-5-500-2750	1
8	Rubber Washer	XB-1127	1	23	Lock Guard	XA-3514**	1
9	Washer 1.50" OD x .81" ID	XB-PW-1316-112	1	24	Torsion Spring	XB-1044**	1
10	Locknut .75"-16	XB-HNH-34-F	1	25	Pin	XA-1055	1
11	Washer 1.75" OD x .56" ID	XB-T-49	3	26	Cotter Pin .13" x 1"	XB-16	2
12L	Left-Hand Release Handle S/A (Part No. 11 must be installed on handle for complete assembly.)	RK-1707-M	1	27	Grease Fitting	XB-H-38	2
12R	Right-Hand Release Handle S/A (Part No. 11 must be installed on handle for complete assembly.)	RK-1707-6	1	28	Manual Secondary Lock Handle	XA-3542-M	1
13	Cam Plate	XA-1705	1	29	Manual Secondary Lock	XA-3528	1
14	Roller	XA-1029	1	30	Bracket Pin	XA-2016	2
15	Bolt .50"-20 x 1.75"	XB-2083	1	31	Roll Pin	XB-21-5-375-1750	2
16	Locknut .50"-20	XB-T-69-A	1	32	Rubber Bushing	XB-0011-2	2

\* Not available individually, order RK-63503  
\*\* Not available individually, order RK-05329

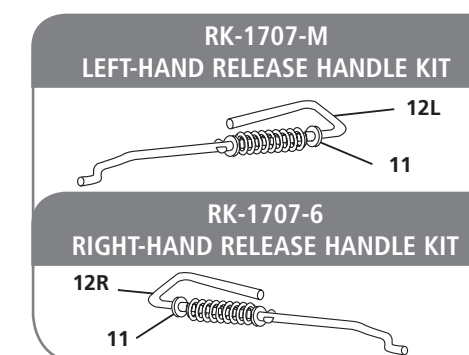
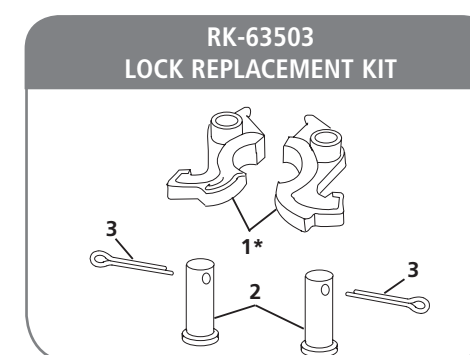
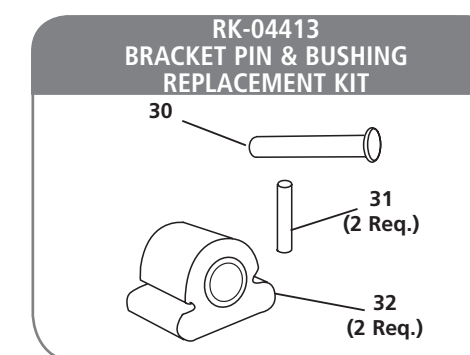
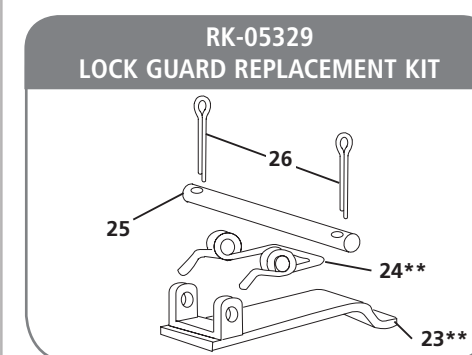

For XA-3501 fifth wheel rebuilding procedures, see SAF-HOLLAND publication XL-FW129.

### Essential service tools designed specifically for HOLLAND Fifth Wheels.



TF-TLN-5001  
Works with all HOLLAND fifth wheels with 2" kingpins except for FW51, FW52, and all SIMPLEX fifth wheels

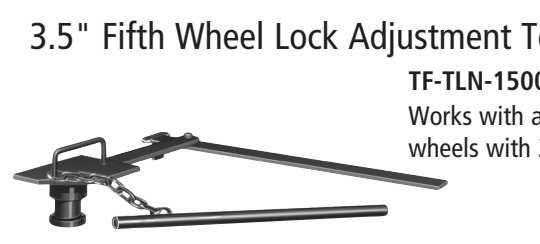

TF-TLN-1500  
Works with all HOLLAND fifth wheels with 3.5" kingpins



Slider Spring Compressor  
TF-TLN-2500  
For HOLLAND traditional sliders only (not for use with ILS sliders)  
For removing and installing springs, retainers and pins of Holland sliding fifth wheels



2" Plug  
TF-0237  
Recommended for lock installation and adjustment for HOLLAND FW35, FW33, and FW31 fifth wheels

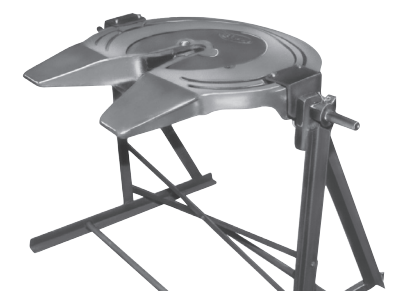

Fifth Wheel Rebuild Stand  
TF-04229-1  
For use with the following top plates: FW35, FW3500, FWAL, FW17, FW51, FW52, FW0070, and FW8

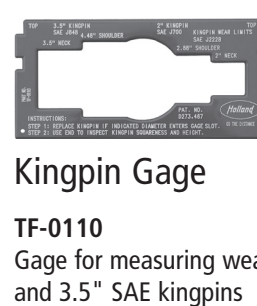

Kingpin Gage  
TF-0110  
Gage for measuring wear on 2" and 3.5" SAE kingpins

SAF-HOLLAND Canada 519.537.3494

Western Canada 604.574.7491

www.safholland.ca