

# Replacement Manual

## FWS1/FWS2 Manual and Air Release Handle



### FWS1/FWS2 Fifth Wheels

Release Handle Replacement Procedures for the XA-S1/XA-S2 Series Top Plates

#### Introduction

This manual provides the information necessary to properly replace the release handle on the XA-S1 and XA-S2 Series Fifth Wheel Top Plates.

Read this manual before using or servicing this product and keep it in a safe location for future reference. Updates to this manual, which are published as necessary, are available on the internet at [www.safholland.us](http://www.safholland.us).

When replacement parts are required, SAF-HOLLAND® highly recommends the use of only SAF-HOLLAND® Original Parts. A list of technical support locations that supply SAF-HOLLAND® Original Parts and an Aftermarket Parts Catalog are available on the internet at [www.safholland.us](http://www.safholland.us) or contact Customer Service at 888-396-6501.

#### Notes, Cautions, and Warnings

Before starting any work on the unit, read and understand all the safety procedures presented in this manual. This manual contains the terms "NOTE", "IMPORTANT", "CAUTION", and "WARNING" followed by important product information. These terms are defined as follows:

**NOTE:** Includes additional information to enable accurate and easy performance of procedures.

**IMPORTANT:** Includes additional information that if not followed could lead to hindered product performance.

#### CAUTION

Used without the safety alert symbol, indicates a potentially hazardous situation which, if not avoided, could result in property damage.

#### CAUTION

Indicates a potentially hazardous situation which, if not avoided, could result in minor or moderate injury.

#### WARNING

Indicates a potentially hazardous situation which, if not avoided, could result in death or serious injury.

#### General Servicing and Safety Instructions

- Read and observe all Warning and Caution hazard alert messages. The alerts provide information that can help prevent serious personal injury, damage to components, or both.

#### WARNING

Failure to follow the instructions and safety precautions in this manual could result in improper servicing or operation leading to component failure which if not avoided could result in death or serious injury.

- All repair and maintenance should be performed by a properly trained technician using proper/special tools, and safe procedures.

**NOTE:** In the United States, workshop safety requirements are defined by federal and/or state Occupational Safety and Health Act (OSHA). Equivalent laws may exist in other countries. This manual is written based on the assumption that OSHA or other applicable employee safety regulations are followed by the location where work is performed.

**NOTE:** Before repairing the HOLLAND® Fifth Wheel review the model number on the identification tag. This replacement procedure applies only to the XA-S1 and XA-S2 series fifth wheels.

**IMPORTANT:** These instructions apply to the proper replacement of the FWS1/XA-S1 and FWS2/XA-S2 release handle. There are other important checks, inspections, and procedures not listed that are necessary, prudent, and/or required by law.

#### WARNING

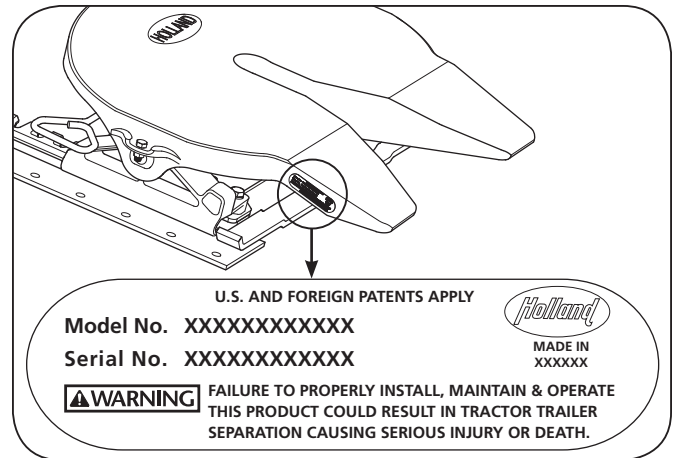
Failure to properly repair and install the fifth wheel could adversely affect performance resulting in tractor trailer separation which, if not avoided, could result in death or serious injury.

## 1. Model Identification

This manual contains the installation procedures for SAF-HOLLAND® replacement kits RK-10990 and RK-11112. Before replacement, verify the correct replacement kit for the fifth wheel top plate being repaired.

Fifth wheel serial tags are located on the left side of the fifth wheel top plate above the fifth wheel bracket pin, or on the pickup ramps as illustrated. The part number and serial number are listed on the tag as indicated (**Figure 1**).

**Figure 1**



## 2. Replacement Kit Contents

RK-10990 REPLACEMENT KIT CONTENTS (FIGURE 2)			
ITEM	DESCRIPTION	PART NUMBER	QTY.
1	Release Handle	XA-10990	1
2	Washer	XB-T-49	1
3	Cotter Pin, 1/8"	84261	1
4	Safety Indicator	XD-11121	1
5	Cotter Pin, 3/16"	XB-11091	1
6	Safety Indicator Pin	XB-10996	1

RK-11112 AIR RELEASE (TOUCHLOC) HANDLE (FIGURE 3)			
ITEM	DESCRIPTION	PART NUMBER	QTY.
1	Release Handle	XA-11112	1
2	Cotter Pin, 1/8"	84261	1
3	Safety Indicator	XD-11121	1
4	Roll Pin, 3/16"	9900181	1
5	Safety Indicator Pin	XB-10996	1

Figure 2

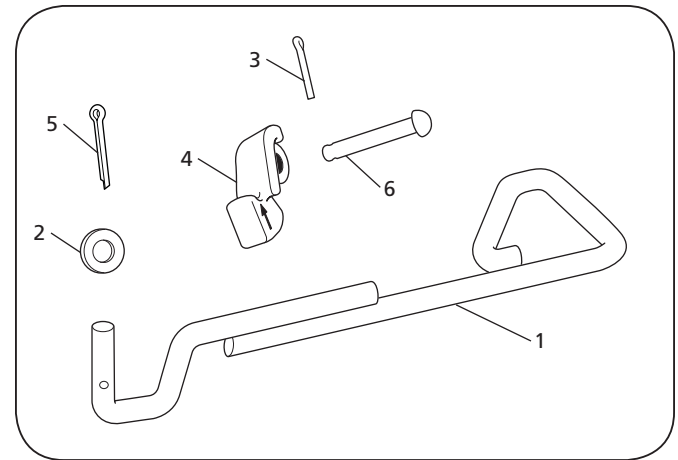
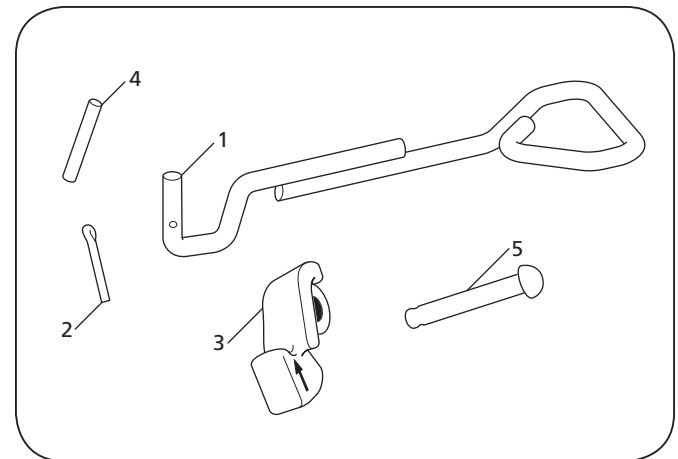


Figure 3



## 3. Replacement Procedures

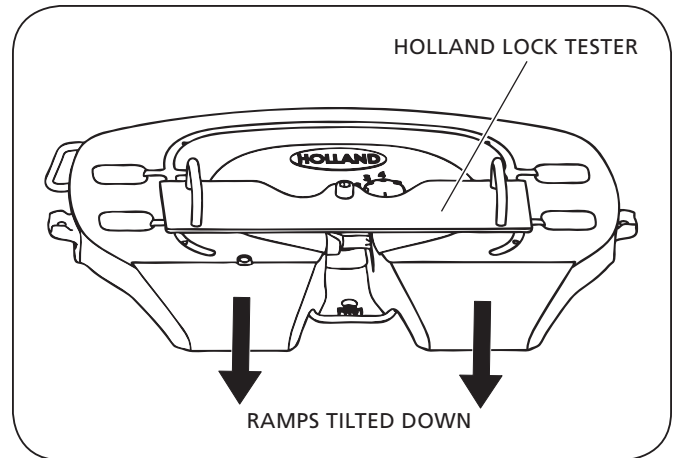
Before performing the following replacement procedures, make sure the fifth wheel is in the normal resting state with ramps tilted down (**Figure 4**).

1. Lock the fifth wheel using a HOLLAND® Lock Tester, Part Number 4000171 (**Figure 4**).
2. Working on the underside of the top plate, remove the cotter pin from the lock indicator pin and detach the lock indicator from the fifth wheel. Discard the cotter pin, lock indicator pin and lock indicator (**Figure 5**).
3. **FWS1/FWS2 Model:**  
Remove the cotter pin and washer from the end of the release handle (**Figure 6**).

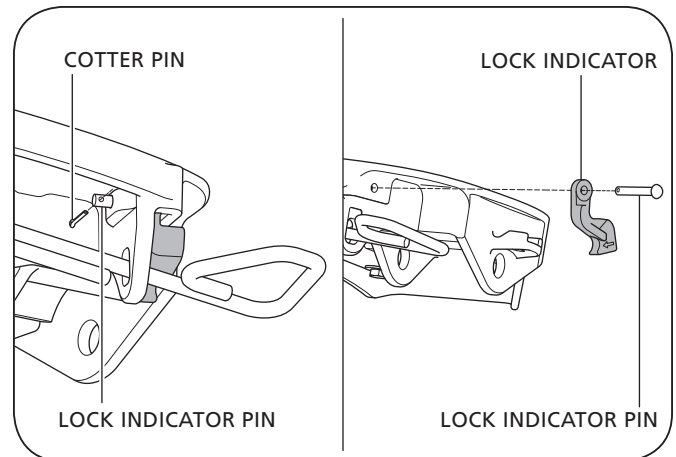
**FWS1/FWS2 Air Release (Touchloc) Model:**

Remove the roll pin from the end of the release handle (**Figure 6**).

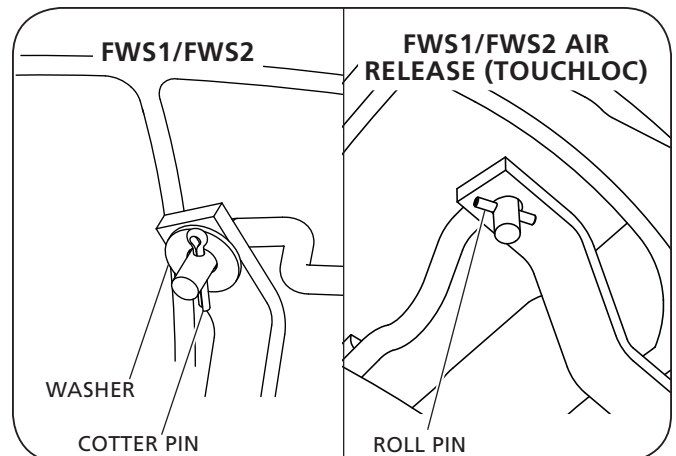
**Figure 4**



**Figure 5**



**Figure 6**

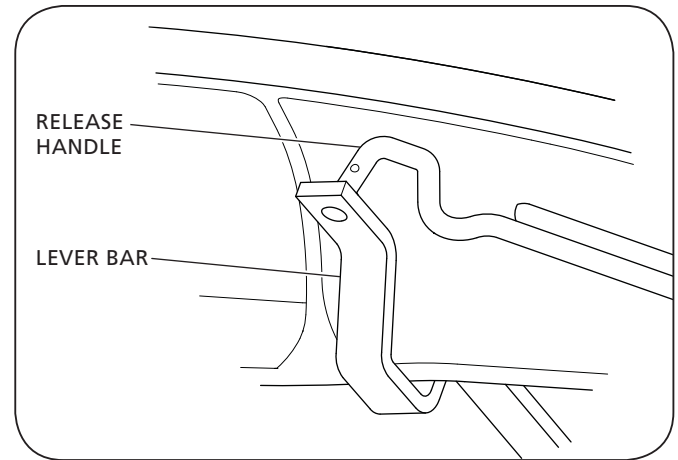


4. Separate the release handle from the lever bar (**Figure 7**).
5. Discard release handle, washer and cotter pin/roll pin.
6. Insert the new release handle through the release handle window in the casting and into the lever bar (**Figure 8**).
7. **FWS1/FWS2 Model:**  
Install the new washer and 3/16" cotter pin into the end of the new release handle. Spread both legs of the cotter pin at a 20° angle minimum (**Figure 9**).

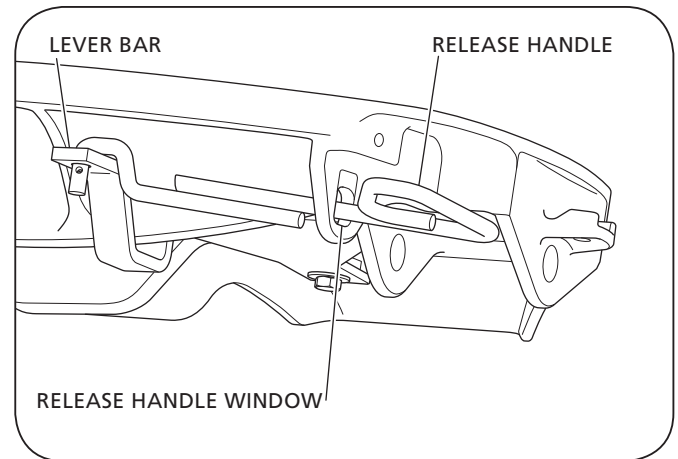
**FWS1/FWS2 Air Release (Touchloc) Model:**

Install the new roll pin into the end of the new release handle (**Figure 9**).

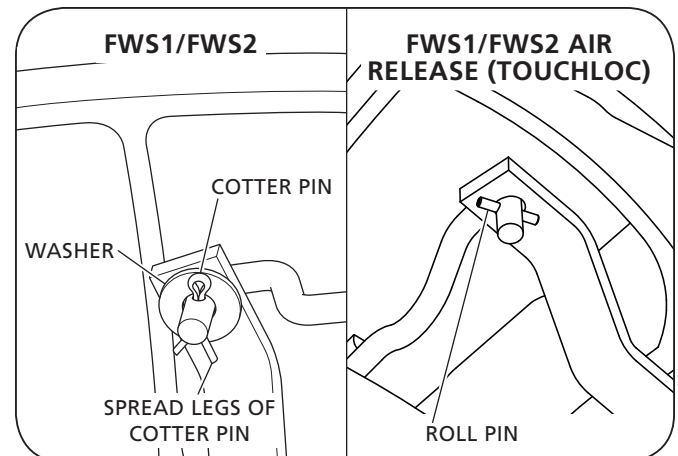
**Figure 7**



**Figure 8**

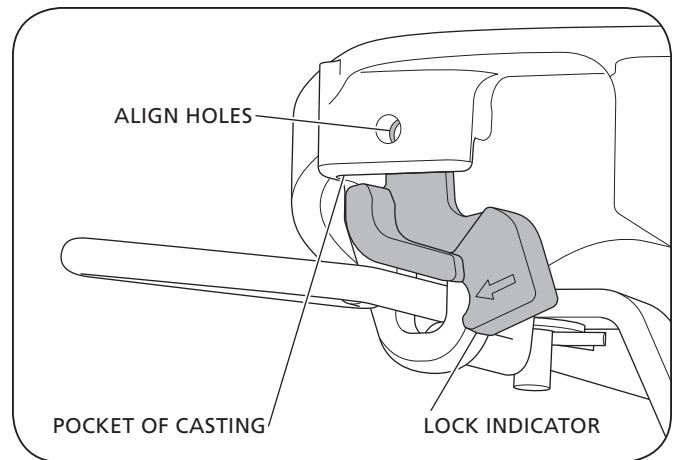


**Figure 9**

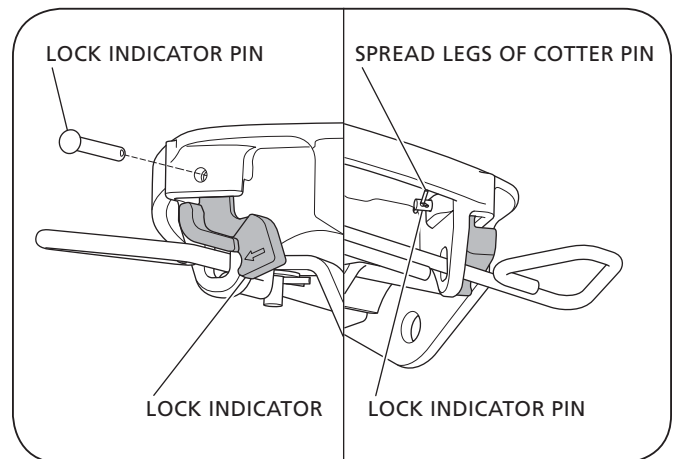


8. Position the lock indicator into the pocket on the release handle window of the casting, ensuring that the lock indicator is in the correct orientation (**Figure 10**).
9. Insert the lock indicator pin through the casting hole and the lock indicator and attach with 1/8" cotter pin. Spread both legs of the cotter pin at a 20° angle minimum (**Figure 11**).

**Figure 10**



**Figure 11**



## 4. Operation and Adjustment

Verify the proper operation of the fifth wheel by locking and unlocking the fifth wheel using a HOLLAND® Lock Tester Part Number 4000171. After each attempt, check that the fifth wheel is properly locked.

**IMPORTANT:** Before using the fifth wheel, visually inspect all components of fifth wheel for proper operation while coupling and uncoupling fifth wheel with lock tester.

**IMPORTANT:** DO NOT use any fifth wheel which does not operate properly.

**⚠ WARNING** Failure to repair an improperly operating fifth wheel could result in tractor trailer separation which, if not avoided, could result in death or serious injury.

1. If fifth wheel is locked, lift release handle up, pull completely out, and up again to hook on casting. If air release equipped, actuate fifth wheel control valve to open lock (**Figure 12**).
2. Firmly position the lock tester into the fifth wheel top plate to lock the fifth wheel (**Figure 13**).
3. Push the lock tester forward so that it is tight against the fifth wheel's front lock. Ensure the lock tester is pressed flat against the surface of the fifth wheel. Scribe a line on the surface of the fifth wheel face along the front edge of lock tester (**Figure 14**).

Figure 12

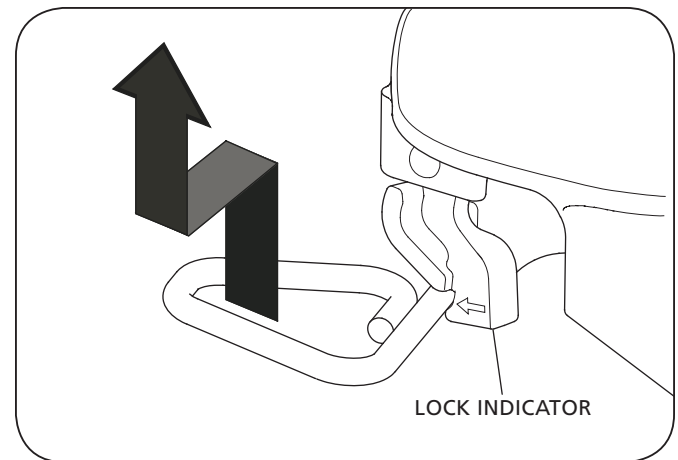


Figure 13

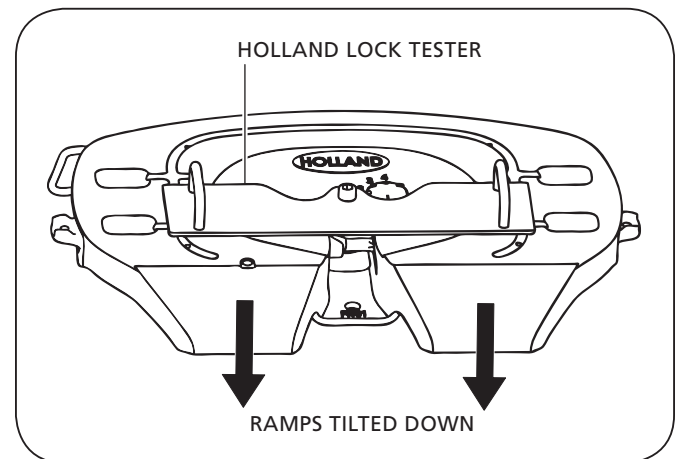
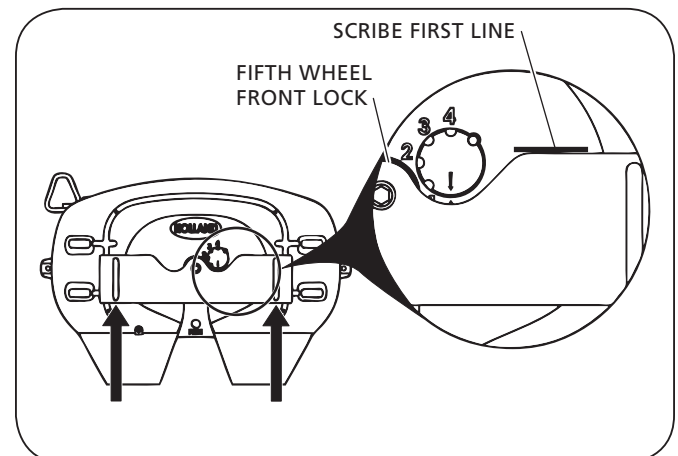


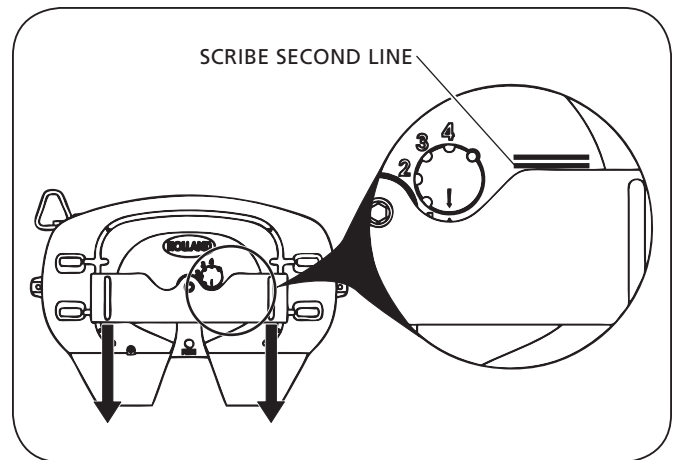
Figure 14



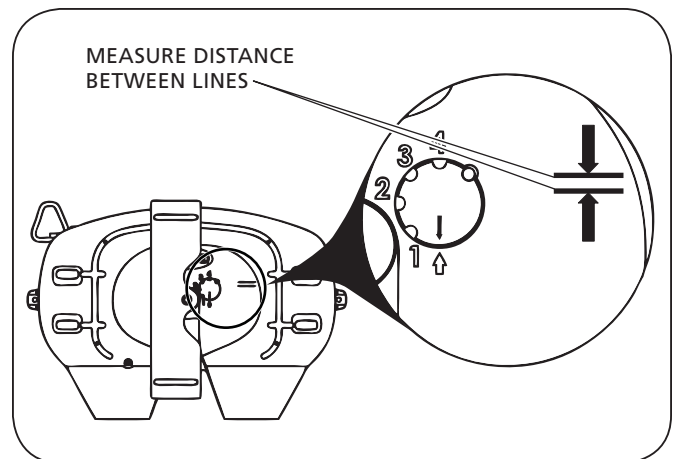
4. Pull the lock tester toward the fifth wheel ramps. Ensure the lock tester is pressed flat against the surface of the fifth wheel. Scribe a second line on the surface of the fifth wheel face along the front edge of the lock tester (**Figure 15**).
5. Rotate the lock tester out of the way and measure the distance between the scribed lines. If distance between lines exceeds 1/8" (3 mm), the lock **MUST** be adjusted tighter (**Figure 16**).
6. To adjust lock:
  - With the lock tester still locked in the fifth wheel, lift up on fifth wheel ramps and rotate fifth wheel to its forward most position (toward the cab).
  - Remove clinch pin from the bottom of the lock adjustment pin (**Figure 17**).
  - Lift the lock adjustment pin and rotate clockwise to the next adjustment position shown on the face of fifth wheel (**Figure 18**).
  - Push the lock adjustment pin into fifth wheel in the new position.
  - Replace clinch pin.
7. Re-check for free play in the locks by repeating Steps 3-5. If free play still exceeds 1/8" (3 mm), repeat Step 6 and rotate lock adjustment pin one more notch.

**NOTE:** If free play greater than 1/8" (3 mm) remains with the lock adjustment pin on the last (fourth) position, then the fifth wheel should be rebuilt using rebuild kit RK-FWS-A-L.

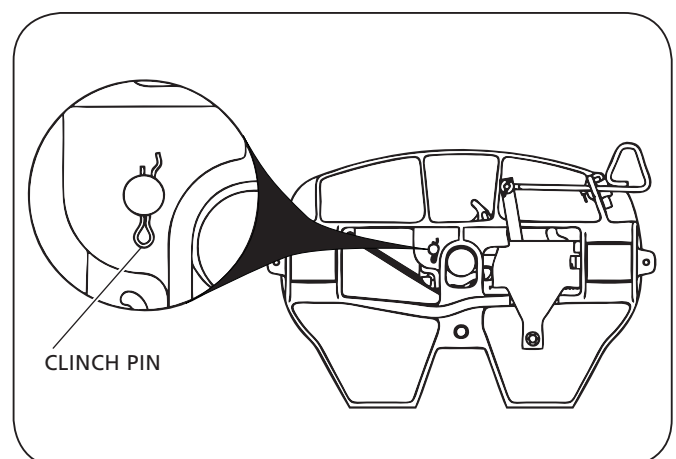
**Figure 15**



**Figure 16**



**Figure 17**





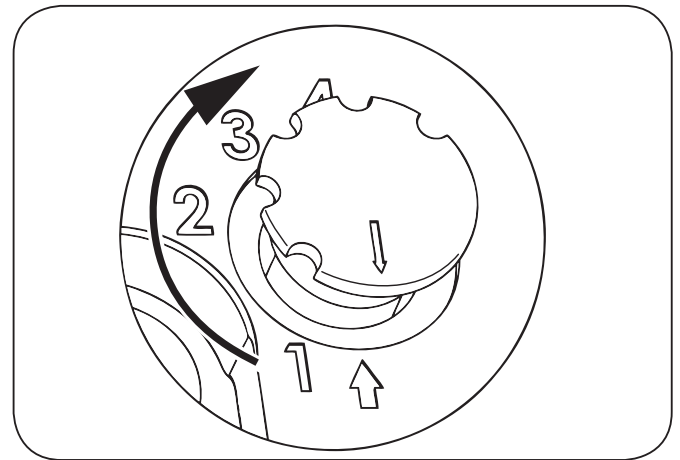
- Verify the proper adjustment and operation by locking and unlocking fifth wheel several times with lock tester. Verify that there is at least 1/16" (1.5 mm) of forward and backward play in the lock by sliding a 1/16" drill bit between the front edge of the kingpin on the lock tester and the front lock (radius) of the fifth wheel (**Figure 19**).

**IMPORTANT:** A minimum of 1/16" (1.5 mm) free play is critical to proper operation of the fifth wheel.

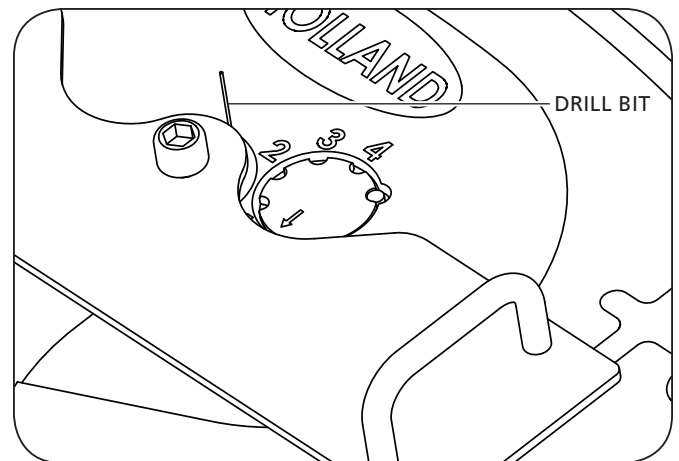
If there is NOT 1/16" (1.5 mm) minimum free play in the lock, the fifth wheel lock adjustment pin MUST be rotated counterclockwise to the next lower position. Re-verify that 1/16" (1.5 mm) minimum play exists using 1/16" (1.5 mm) drill bit as described above. Check that the fifth wheel is properly locked.

- Rotate lock adjustment tool from side-to-side to ensure that the lock is not over tightened. The lock should NOT grip the kingpin and the lock tester should rotate freely.

**Figure 18**



**Figure 19**









From fifth wheel rebuild kits to suspension bushing repair kits, SAF-HOLLAND Original Parts are the same quality components used in the original component assembly.

SAF-HOLLAND Original Parts are tested and designed to provide maximum performance and durability. Will-fits, look-alikes or, worse yet, counterfeit parts will only limit the performance potential and could possibly void SAF-HOLLAND's warranty. Always be sure to spec SAF-HOLLAND Original Parts when servicing your SAF-HOLLAND product.

**SAF-HOLLAND USA • 888.396.6501 • Fax 800.356.3929**  
[www.safholland.us](http://www.safholland.us)

**SAF-HOLLAND CANADA • 519.537.3494 • Fax 800.565.7753**  
**WESTERN CANADA • 604.574.7491 • Fax 604.574.0244**  
[www.safholland.ca](http://www.safholland.ca)

**SAF-HOLLAND MEXICO • 52.1.55.5456.8641 • Fax 52.55.58162230**  
[www.safholland.com.mx](http://www.safholland.com.mx)

[info@safholland.com](mailto:info@safholland.com)