



SAF-HOLLAND Group

## HOLLAND TERMINAL TRACTOR FIFTH WHEELS

90027837 (XA-351-03505) & 90027838 (FW35-03344)



TWO INDUSTRY SOLUTIONS FOR INCREASED DURABILITY AND LIFTING PERFORMANCE



# HOLLAND **TERMINAL TRACTOR** FIFTH WHEELS ARE BUILT FOR A BEATING



When your terminal tractor couples over 150 loads per shift, seven days a week, 365 days a year, your fifth wheel better be built to take a beating. HOLLAND terminal tractor fifth wheels have been the proven leader and world standard in ports, distribution centers, terminals and rail yards for over 30 years. HOLLAND terminal tractor fifth wheels are not just a modified on-highway fifth wheel, they are designed specifically for the challenges of yard operations. With a trusted design and proven features, including durable cast steel construction and specially designed twin locks, HOLLAND terminal tractor fifth wheels provide the reliability you need when seconds count.

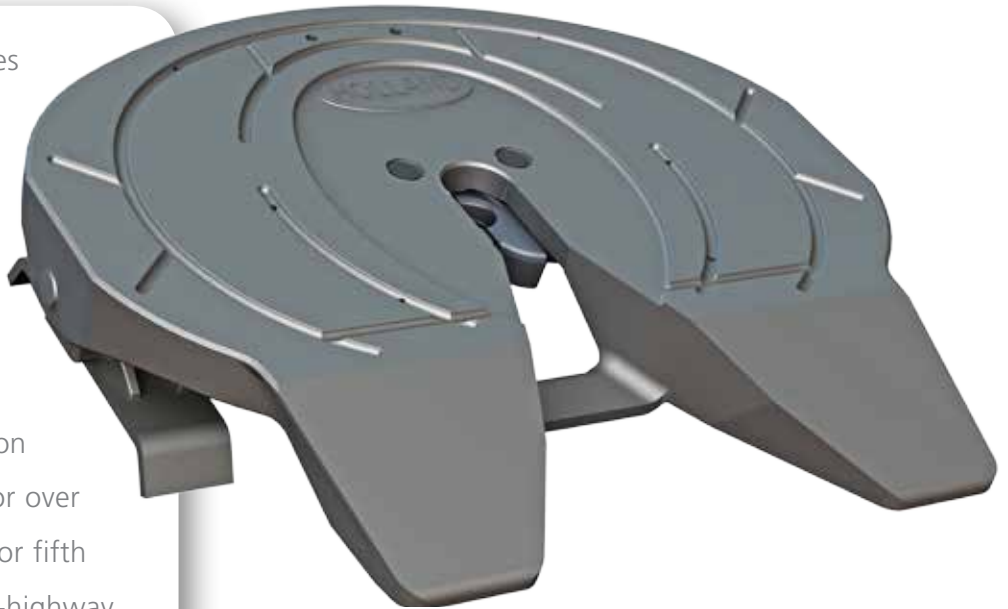

**90027837  
(XA-351-03505)**

**&**

**90027838  
(FW35-03344)**

**CAPACITY:**

70,000 lbs. (31,750 kg)  
Maximum Vertical Load



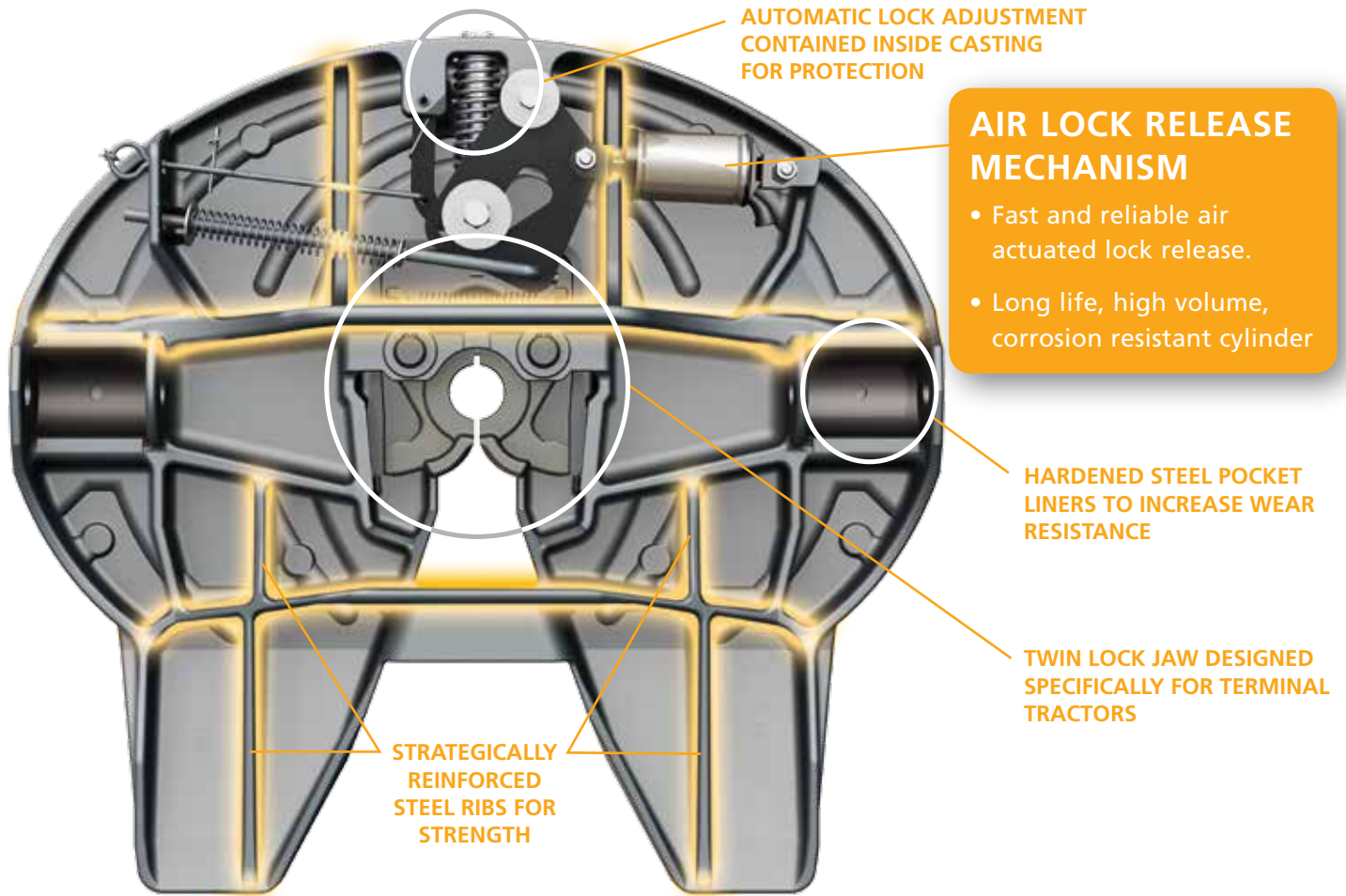

**AIR LOCK RELEASE MECHANISM**

- Fast and reliable air actuated lock release.
- Long life, high volume, corrosion resistant cylinder

**HARDENED STEEL POCKET LINERS TO INCREASE WEAR RESISTANCE**

**TWIN LOCK JAW DESIGNED SPECIFICALLY FOR TERMINAL TRACTORS**

**STRATEGICALLY REINFORCED STEEL RIBS FOR STRENGTH**

### CAST STEEL CONSTRUCTION

HOLLAND terminal tractor top plates are the only terminal fifth wheels built from cast steel technology and designed specifically for unmatched durability and reliability in yards, ports or distribution centers.

- Cast steel design is more reliable and forgiving than traditional ductile top plates.
- Additional cast steel ribs provide unparalleled strength and durability in high stress environments.

### SUPERIOR TWIN LOCK DESIGN

- Forged, hardened and machined cast steel lock jaws designed specifically for terminal tractors for a more forgiving coupling at different heights, angles or terrains.
- Efficient range of lock component motion cuts down coupling time.
- Lock jaws completely encompass kingpin for enhanced reliability.
- Automatically adjusting locks eliminate downtime for regular manual adjustments.

### SERVICE PARTS INFORMATION

FIFTH WHEEL ASSEMBLY	TOP PLATE REPLACEMENT	REBUILD KITS (INCLUDES ALL PARTS)	REPLACEMENT AIR CYLINDER	LOCK JAW KIT	RELEASE COMPONENTS KIT (NOT INCLUDING AIR CYLINDER)
90027838 (FW35-03344)	90027837 (XA-351-03505)	90027760 (RK-351-03505)	90026594 (XA-2524-R-13)	90026597 (RK-351-08332)	90027298



**SAF-HOLLAND** is a leading supplier of highly efficient components, systems and service programs in the global commercial vehicle industry. Our three core product brands are recognized for delivering innovative solutions that optimize fleet operations in every corner of the world.



**TRAILER AXLES AND  
SUSPENSION SYSTEMS**



**COUPLING AND LIFTING  
TECHNOLOGIES**



**SUSPENSIONS FOR  
TRUCKS AND BUSES**

With our team of over 3,000 employees and a worldwide network of over 9,000 service partners, we serve our fleet customers with know-how and passion, and always focused on one target: **Engineering your road to success.** Anywhere in the world. Under any conditions. 365 days a year.

**HIGHLY EFFICIENT COMPONENTS AND SYSTEMS FOR TRUCKS AND TRAILERS**



EUROPE | AMERICAS | AFRICA | ASIA | MIDDLE EAST | AUSTRALIA

[safholland.com](http://safholland.com)

**SAF-HOLLAND, Inc.**  
888.396.6501

**SAF-HOLLAND Canada Limited**  
519.537.3494  
Western Canada 604.574.7491



**Kalmar USA, Inc.**  
888.229.6300  
888.229.6356 Fax