

Pocket Insert Replacement Terminal Tractor Fifth Wheels

FW35TT Series Fifth Wheels XA-351-TT Series Top Plates

General Safety Information

This document contains procedures to replace the pocket inserts on the XA-351-TT Series Fifth Wheel Top Plates.

NOTE: In the United States, workshop safety requirements are defined by federal and/or state Occupational Safety and Health Act. Equivalent laws may exist in other countries. This document is written based on the assumption that OSHA or other applicable employee safety regulations are followed by the location where work is performed.

IMPORTANT: All maintenance must be performed while the tractor is uncoupled from the trailer.

Read and observe all Warning and Caution hazard alert messages in this publication. They provide information that can help prevent serious personal injury, damage to components, or both.

All fifth wheel replacement procedures must be performed by a properly trained technician using proper tools and safe procedures.

IMPORTANT: You must read and understand all of the procedures contained in this manual before attempting any replacement procedures.

⚠ WARNING Failure to follow all of the procedures contained in this manual may cause a hazardous condition to develop which, if not avoided, may result in death or serious injury.

IMPORTANT: Prior to operation of the fifth wheel you must be thoroughly satisfied that the fifth wheel has been properly installed on the vehicle.

Failure to properly install the fifth wheel can adversely affect performance resulting in tractor trailer separation which, if not avoided, may result in death or serious injury.

Only SAF-HOLLAND Original Parts should be used.

A list of SAF-HOLLAND technical support locations to supply SAF-HOLLAND Original Parts can be found at www.safholland.us or contact our Customer Service group at 888-396-6501.

RK-PKT-5

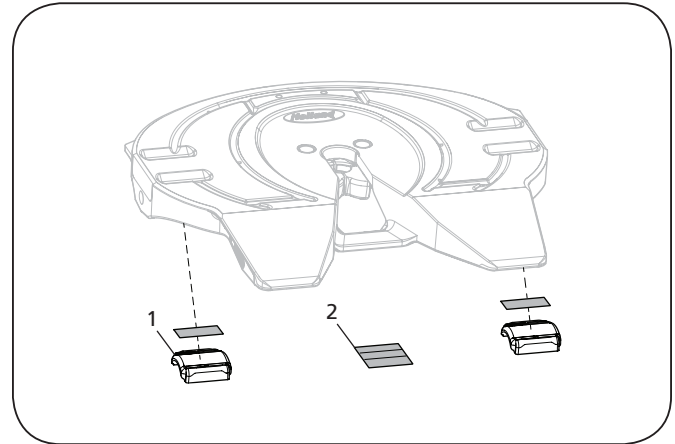

RK-PKT-5 POCKET INSERT REPLACEMENT KIT

ITEM	DESCRIPTION	PART NO.	QTY.
1	Pocket Insert	XD-12026	2
2	Tape Pad	XB-09422	1*

* Two (2) tape strips required; Two (2) provided as spares.

Pocket Insert Replacement

Top Plate Removal

1. Clean off excessive grease, grime and dirt from top plate.
2. Remove the clinch pin from the bracket pin on both sides of the fifth wheel top plate (**Figure 1**).

NOTE: Set aside and retain the clinch pins for re-use later in this procedure.

3. Using a pry bar, pull bracket retention pins out of fifth wheel top plate (**Figure 1**).
4. Disconnect air lines from the air release cylinder. If fifth wheel is equipped with auto-lube, disconnect grease lines.
5. Using a lifting device capable of lifting 500 lbs. (227 kg), remove the top plate from the mounting base. Place fifth wheel upside down on a flat, clean working area.

NOTE: Follow instructions published by lifting device manufacturer for proper operation of lifting device.

Pocket Insert Installation

1. Remove old pocket inserts and discard.
2. Clean pocket area of casting and apply a strip of double-face tape in bottom of pockets. Install new pocket inserts by pressing down into pockets (**Figure 2**).

Top Plate Installation

1. Using a lifting device capable of lifting 500 lbs. (227 kg) to turn fifth wheel over, install the fifth wheel top plate onto its mounting base.
2. Install bracket pins through the fifth wheel casting and mounting base and secure by installing the clinch pins (**Figure 1**).

⚠ WARNING Failure to properly install clinch pins could result in tractor trailer separation which, if not avoided, could result in death or serious injury.

3. Re-connect air lines to the air release cylinder and grease lines to the auto-lube connections.
4. Check for free and proper articulation. Make sure fifth wheel does not bind.
5. Check operation of fifth wheel using the appropriate Holland lock tester that is available from your local SAF-HOLLAND distributor.

Figure 1

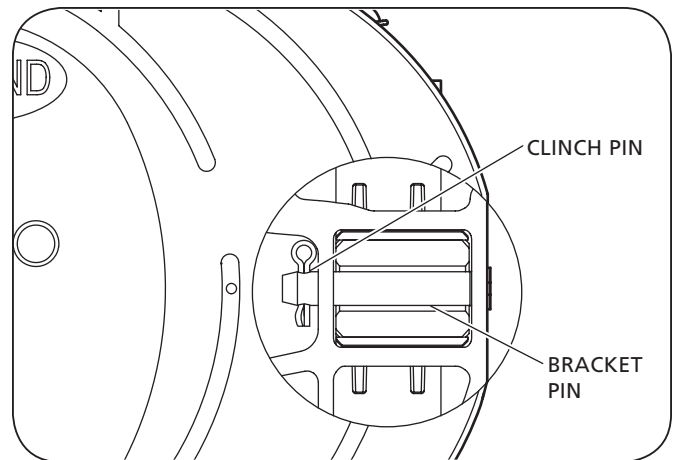

Figure 2

