

**NEW**

# **FW35TT**<sup>TM</sup>

**TERMINAL TRACTOR FIFTH WHEEL**



SAF-HOLLAND Group

***The STRONGEST, FASTEST, and MOST RELIABLE FIFTH WHEEL BUILT SPECIFICALLY for Terminal Tractors***

Over 50 years ago HOLLAND developed the first fifth wheel for terminal tractors. Today, this strong tradition continues with the introduction of the new, multi-feature enhanced FW35TT.



*Rated for*  
**80,000 lbs.**  
**CAPACITY**



**NEW**

# **FWB5TT™**

TERMINAL TRACTOR FIFTH WHEEL

# THE BEST

**MORE DURABLE**  
**EASIER TO MAINTAIN**  
**FUNCTIONALLY SUPERIOR**

Increased to  
**80,000 lbs.**  
**CAPACITY**  
Maximum Vertical Load

**1** STRATEGICALLY STRENGTH ENHANCED RIB STRUCTURE

The main rib has been beefed up and additional ribs are built into the kingpin throat area. The bridge is made stronger with increased thickness and strategically located gussets.



**2** 80,000 lbs. CAPACITY TOP PLATE

Top plate is cast with higher strength steel alloy with an increased top plate thickness for long life performance.



**3** EASY LOCK SET REPLACEMENT

Easy 15 minute lock set replacement – “Slip-Fit” lock pins with lock nut retention for easy and quick removal. Locks now slide out as a complete set for easy lock-only replacement.

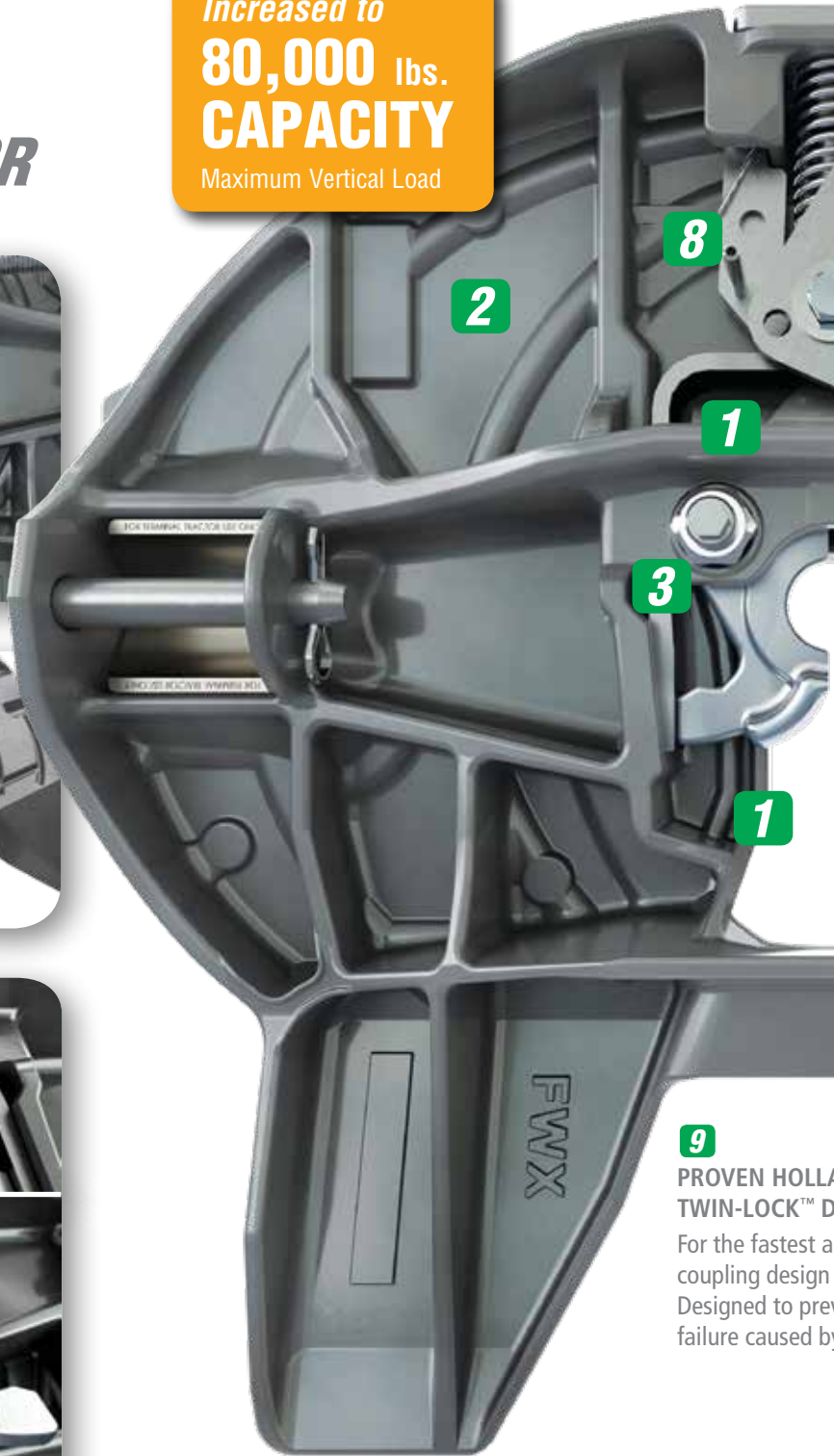

**9** PROVEN HOLLAND TWIN-LOCK™ DESIGN  
For the fastest and most secure coupling design.  
Designed to prevent coupling failure caused by

SEE THE TWIN-LOCK™ IN ACTION!

# THE STRONGEST, FASTEST AND MOST

# T IS EVEN BETTER



SAF-HOLLAND Group



SEE THE  
FULL STORY  
VIDEO



#### 4 REMOVABLE SPRING RETAINER

Makes for quick and easy removal of the yoke shaft spring. No need to compress the spring by hand to install.



#### 5 NOLUBE POCKET LINERS

NoLube Pocket Liner inserts with easy to remove clinch pin for quick and easy replacement. No grinding or tools required to replace pocket liners.



#### 6 LOCK-DOWN MODE FOR ADDED COUPLING SECURITY

New double acting air cylinder provides a new level of coupling security with an integrated "Lock-Down" mode that is automatically activated when the driver releases the trailer brakes. Prevents the potential for dropped trailers when properly coupled.



#### 7 OPTIMIZED CAM PLATE

Engineered for smoother operation throughout the coupling and uncoupling process.

#### 8 INTEGRATED AUTOMATIC SECONDARY LOCK

Eliminates the need for a manual handle activated secondary lock.

AND  
DESIGN  
and most reliable  
in the industry.  
vent coupling delay or  
y kingpin bounce out.

# RELIABLE TERMINAL TRACTOR FIFTH WHEEL



**SAF-HOLLAND** is a leading supplier of highly efficient components, systems and service programs in the global commercial vehicle industry. Our three core product brands are recognized for delivering innovative solutions that optimize fleet operations in every corner of the world.



**TRAILER AXLES AND  
SUSPENSION SYSTEMS**



**COUPLING AND LIFTING  
TECHNOLOGIES**



**SUSPENSIONS FOR  
TRUCKS AND BUSES**

With our team of over 3,000 employees and a worldwide network of over 9,000 service partners, we serve our fleet customers with know-how and passion, and always focused on one target: **Engineering your road to success.** Anywhere in the world. Under any conditions. 365 days a year.

**HIGHLY EFFICIENT COMPONENTS AND SYSTEMS FOR TRUCKS AND TRAILERS**



EUROPE | AMERICAS | AFRICA | ASIA | MIDDLE EAST | AUSTRALIA

[safholland.com](http://safholland.com)



**SAF-HOLLAND, Inc.**  
888.396.6501 Fax 800.356.3929

**SAF-HOLLAND Canada Limited**  
519.537.3494 Fax 800.565.7753  
Western Canada 604.574.7491 Fax 604.574.0244