

Owner's Manual

HOLLAND Kompensator[®]

Stationary:

FW35-77xx Series
FW7040-77xx Series

Slider:

FW35K3xxxxxx Series
FW70K3xxxxxx Series

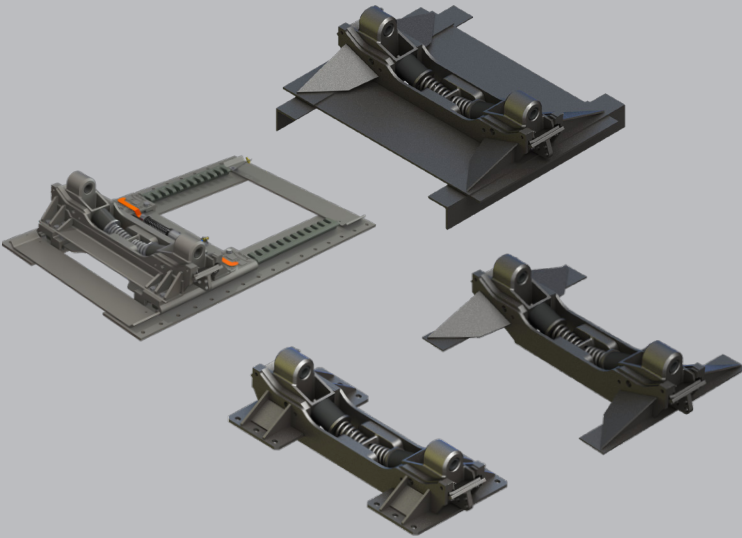

Contents Page

Introduction 2

Notes, Cautions, and Warnings 2

Section 1 – General Safety Instructions 3

Section 2 – Lubrication 4

Section 3 – General Inspection 6

Contents Page

Section 4 – Fifth Wheel
Locking Mechanism 7

Section 5 – HOLLAND Kompensator Base:
Measure Fore/Aft Movement 7

Section 6 – HOLLAND Kompensator Base:
Measure Upward Movement 9

Introduction

This manual provides the information necessary for the proper operation and maintenance of Stationary and Sliding HOLLAND® Kompensators for FW35, FW7040 and FW70 Series Fifth Wheels.

Read this manual before using or servicing this product and keep it in a safe location for future reference. Updates to this manual, which are published as necessary, are available on the internet at www.safholland.us.

When replacement parts are required, SAF-HOLLAND® highly recommends the use of ONLY SAF-HOLLAND Original Parts. A list of technical support locations that supply SAF-HOLLAND Original Parts and an Aftermarket Parts Catalog are available on the internet at www.safholland.us or contact Customer Service at 888-396-6501.

Notes, Cautions, and Warnings

Before starting any work on the unit, read and understand all the safety procedures presented in this manual. This manual contains the terms "NOTE", "IMPORTANT", "CAUTION", and "WARNING" followed by important product information. These terms are defined as follows:

NOTE: Includes additional information to enable accurate and easy performance of procedures.

IMPORTANT: Includes additional information that, if not followed, could lead to hindered product performance.

CAUTION Used without the safety alert symbol, indicates a potentially hazardous situation which, if not avoided, could result in property damage.

CAUTION Indicates a potentially hazardous situation which, if not avoided, could result in minor or moderate injury.

WARNING Indicates a potentially hazardous situation which, if not avoided, could result in death or serious injury.

1. General Safety Instructions

- Read and observe all Warning and Caution hazard alert messages. The alerts provide information that can help prevent serious personal injury, damage to components, or both.

⚠ WARNING Failure to follow the instructions and safety precautions in this manual could result in improper servicing or operation leading to component failure which, if not avoided, could result in death or serious injury.

- HOLLAND Kompensator installation and maintenance **MUST** be performed by a properly trained technician using proper/special tools, and safety procedures.

NOTE: In the United States, workshop safety requirements are defined by federal and/or state Occupational Safety and Health Act (OSHA). Equivalent laws could exist in other countries. This manual is written based on the assumption that OSHA or other applicable employee safety regulations are followed by the location where work is performed.

NOTE: The maintenance procedures contained in this manual apply mainly to the HOLLAND Kompensator base subassembly portion of the fifth wheel assembly. Additional procedures beyond those discussed in this manual are required for the fifth wheel top plate. Contact SAF-HOLLAND Customer Service at 888-396-6501 for the appropriate additional information.

IMPORTANT: All maintenance **MUST** be performed while the tractor is uncoupled from the trailer.

2. Lubrication

IMPORTANT: The following should be performed before putting into use and then **at least once per week** or more frequently as required by operating conditions. Perform the following steps **while in the uncoupled condition** to allow correct application of lubricant.

While lifting up on the fifth wheel top plate, apply grease to the:

1. Fittings on the fifth wheel top plate that supply grease to the top plate pockets (**Figure 1**).

NOTE: Low Lube or NoLube™ top plates DO NOT have these fittings. All newer model fifth wheel top plates have pocket inserts which eliminate the need to grease the pockets. Only grease the pockets if the grease fitting is installed on the fifth wheel.

2. Fittings on the side of each shoe that fill a reservoir that requires approximately two (2) lbs. of grease (**Figure 2**).
3. Fittings (four (4) total) on the base ends of the cradle (**Figure 2**).
4. Fittings (four (4) total) on the front and back of the cradle (**Figure 2**).

Figure 1

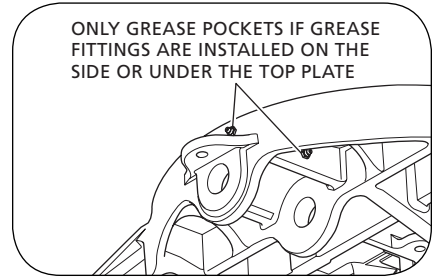
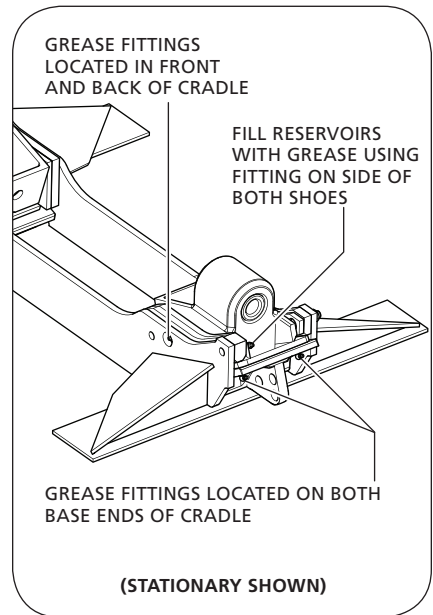

Figure 2



For Sliding Kompensators:

1. Spray the spring-covered piston shaft thoroughly with penetrating oil (**Figure 3**).

IMPORTANT: DO NOT use any abrasives on the exposed shaft as they could damage the piston shaft.

2. Remove the supply air line and add two to four (2-4) drops of air tool oil to the cylinder through the supply fitting. Re-install the supply air line (**Figure 4**).
3. Activate and de-activate the air cylinder two to three (2-3) times to work the air tool oil into the cylinder and onto the piston and verify proper operation.

Figure 3

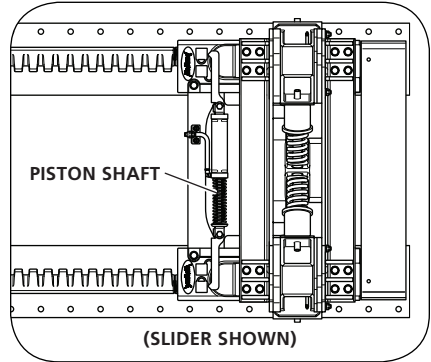
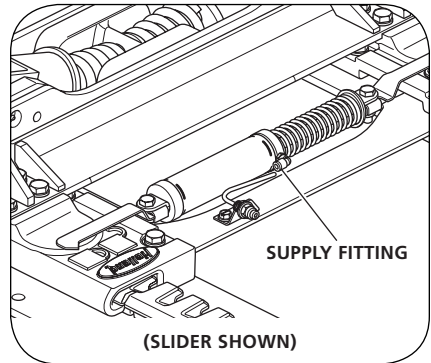

Figure 4



3. General Inspection

IMPORTANT: All of the following **MUST** be performed after the initial 5,000 miles of service and then every 60,000 miles or six (6) months, whichever comes first. **Perform all inspections and adjustments after a thorough steam cleaning.**

NOTE: Severe service applications could require more frequent intervals.

1. Inspect the fifth wheel mounting. Check each bolt and replace any that are loose, missing, or damaged. Check for broken, distorted, or cracked components and check welds for cracks. Repair or replace as needed (**Figures 5 and 6**).
2. When inspecting the bolts that secure the HOLLAND Kompensator to the slider mounting brackets, torque all sixteen (16) bolts to 180-210 ft.-lbs. (244-285 N•m) (**Figure 7**).
3. Inspect the fifth wheel top plate and HOLLAND Kompensator assembly for bent, worn, cracked, or broken parts. Replace with HOLLAND parts only (**Figures 5 and 6**).

⚠ WARNING DO NOT use any fifth wheel which does NOT operate properly.

Figure 5

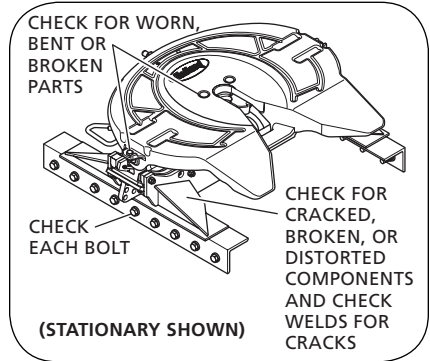

Figure 6

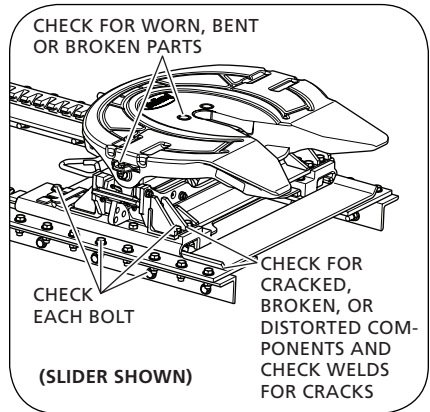
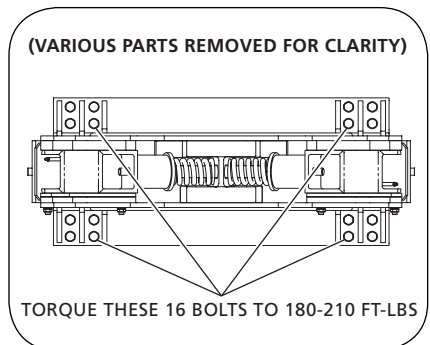

Figure 7



4. Fifth Wheel Locking Mechanism

IMPORTANT: All of the following **MUST** be performed after the initial 5,000 miles of service and then every 60,000 miles or six (6) months, whichever comes first. **Perform all inspections and adjustments after a thorough steam cleaning.**

1. Test the operation of the fifth wheel locking mechanism using HOLLAND Lock Tester Part No. TF-TLN-5001 (for a 2" kingpin) or Part No. TF-TLN-1500 (for a 3-1/2" kingpin), both available from a local HOLLAND distributor.
2. Fifth wheels, depending on each model, have differing instructions for testing the locks and performing adjustment procedures. Refer to the specific Fifth Wheel's Owner's Manual available on the internet at www.safholland.us or contact Customer Service at 888-396-6501.

⚠ WARNING Failure to maintain proper fifth wheel adjustment could result in loss of vehicle control which, if not avoided, may result in death or serious injury.

3. The trailer kingpin should also be inspected for wear and damage. Use HOLLAND Kingpin Gage Part No. TF-0110, available from a local HOLLAND distributor, to aid in this inspection.

5. HOLLAND Kompensator Base: Measure Fore/Aft Movement

IMPORTANT: All of the following **MUST** be performed after the initial 5,000 miles of service and then every 60,000 miles or six (6) months, whichever comes first. **Perform all inspections and adjustments after a thorough steam cleaning.**

NOTE: Some fifth wheel assemblies have replaceable pocket inserts installed between the fifth wheel top plate and mounting base. Take care when removing the fifth wheel top plate not to lose the pocket inserts.

⚠ CAUTION Failure to prevent pocket inserts from falling out of the top plate could cause a potentially hazardous situation which, if not avoided, could result in minor or moderate injury.

1. Remove the bracket pin retention bolts and nuts from both sides of the fifth wheel top plate and discard (**Figure 8**).
2. Using a pry bar, pull the bracket pins out of the fifth wheel top plate and set aside (**Figure 8**).
3. Using a lifting device capable of lifting 500 lbs. (227 kg), remove the top plate from the mounting base.

NOTE: Follow the instructions published by the lifting device manufacturer for proper operation of the lifting device.

4. Measure the fore and aft movement of the shoes in the HOLLAND Kompensator base (**Figure 9**).
5. If movement exceeds .060" (1.52 mm), shims and/or new bearing plates **MUST** be added by following these procedures:
 - Remove shoes and disassemble.
 - Remove the bearing plates and measure the thickness. If less than .31" (7.9 mm) thick, replace with a new HOLLAND bearing plate (**Figure 10**).

Figure 8

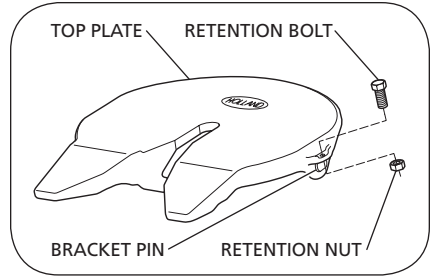

Figure 9

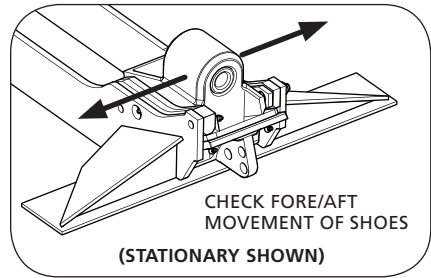
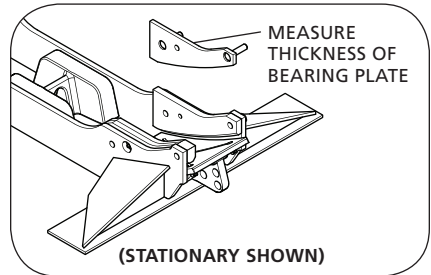

Figure 10



- Install the shims, bearing plates and shoes (**Figures 11 and 12**).
 - Re-check for free lateral movement of the shoe in the frame. DO NOT over shim.
6. Inspect the cushions and other components for distortion, splitting or cracking. If disassembly is required, follow steps 4 through 7 under Section 6 and replace if needed.

6. HOLLAND Kompensator Base: Measure Upward Movement

IMPORTANT: All of the following MUST be performed after the initial 5,000 miles of service and then every 60,000 miles or six (6) months, whichever comes first. **Perform all inspections and adjustments after a thorough steam cleaning.**

Measure upward clearance on the assembly. Do this on one (1) side at a time by lifting the fifth wheel top plate upward manually with the aid of a bar (**Figure 13**). Clamp the shoe on the opposite side to prevent its movement, which would affect the measurement (**Figure 13**). If the total movement exceeds .50" (12.7 mm), the unit should be disassembled for further inspection by following these procedures:

NOTE: Some fifth wheel assemblies have replaceable pocket inserts installed between the fifth wheel top plate and mounting base. Take care when removing the fifth wheel top plate not to lose the pocket inserts.

Figure 11

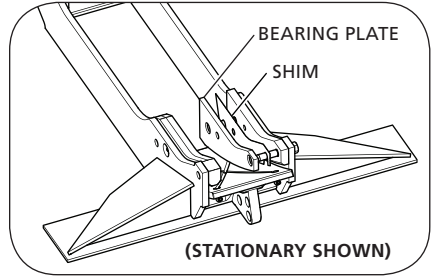

Figure 12

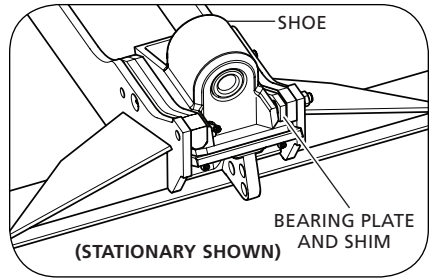
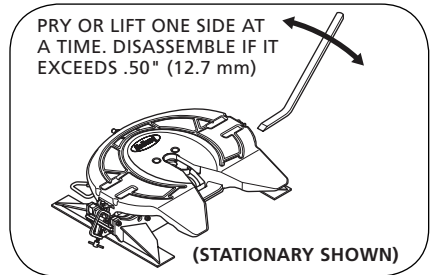

Figure 13



CAUTION Failure to prevent pocket inserts from falling out of the top plate could cause a potentially hazardous situation which, if not avoided, could result in minor or moderate injury.

1. Remove the bracket pin retention bolts and nuts from both sides of the fifth wheel top plate and discard (**Figure 14**).
2. Using a pry bar, pull the bracket pins out of the fifth wheel top plate and set aside (**Figure 14**).
3. Using a lifting device capable of lifting 500 lbs. (227 kg), remove the top plate from the mounting base.

NOTE: Follow the instructions published by the lifting device manufacturer for proper operation of the lifting device.

4. Remove all the loose internal parts (shoes, tie rod, etc.).
5. Inspect all the parts for distortion, wear and cracking. Replace, if necessary, with HOLLAND parts only.
6. Measure the thickness of the curved base of the shoe. The shoe **MUST** be replaced if the base thickness measures less than .31" (7.9 mm) (**Figure 15**).
7. Reassemble and lubricate as noted in Section 2. Check for free lateral and fore/aft movement of the shoes after reassembly.

NOTE: The HOLLAND Kompensator base, fully assembled with a top plate and proper lubrication, could have approximately 1" (25.4 mm) of side-to-side movement.

NOTE: For severe dusty/dirty environments, shoe dust covers (**Figure 16**) are available. Request HOLLAND part numbers XA-0128-L and XA-0128-R.

Figure 14

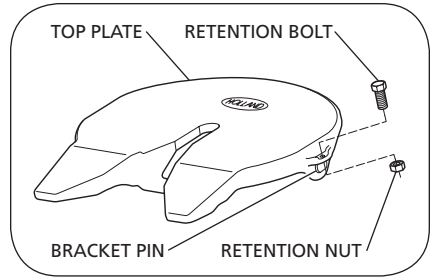

Figure 15

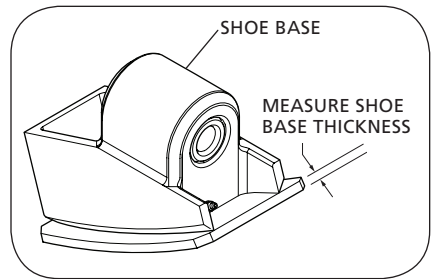
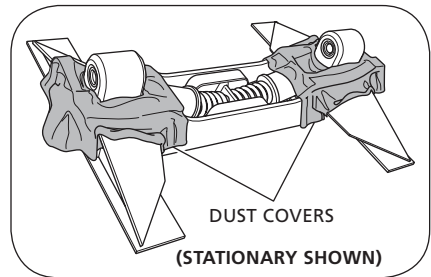

Figure 16







From fifth wheel rebuild kits to suspension bushing repair kits, SAF-HOLLAND Original Parts are the same quality components used in the original component assembly.

SAF-HOLLAND Original Parts are tested and designed to provide maximum performance and durability. Will-fits, look-alikes or, worse yet, counterfeit parts will only limit the performance potential and could possibly void SAF-HOLLAND's warranty. Always be sure to spec SAF-HOLLAND Original Parts when servicing your SAF-HOLLAND product.

SAF-HOLLAND USA • 888.396.6501 • Fax 800.356.3929

www.safholland.us

SAF-HOLLAND CANADA • 519.537.3494 • Fax 800.565.7753

WESTERN CANADA • 604.574.7491 • Fax 604.574.0244

www.safholland.ca

SAF-HOLLAND MEXICO • 52.1.55.5456.8641 • Fax 52.55.58162230

www.safholland.com.mx

info@safholland.com

SAF-HOLLAND INC.
1950 Industrial Blvd., Muskegon, MI 49443
www.safholland.com

