

Owner's Manual

FW17 Series Fifth Wheel

Operation, Maintenance and
Troubleshooting Procedures

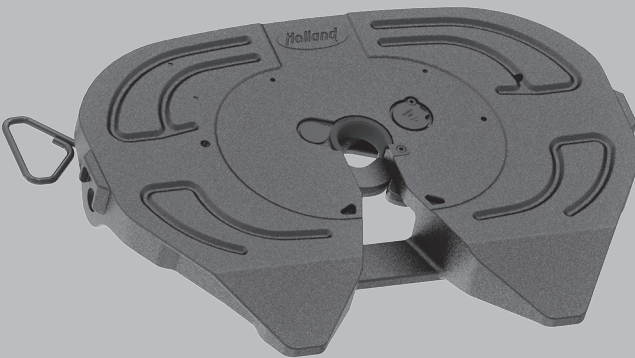

Contents	Page
Introduction	2
Notes, Cautions, and Warnings	2
Section 1 – General Safety Instructions	3
Section 2 – Model Identification.....	4
Section 3 – Generation Identification	4
Section 4 – Decal Requirements	5
Section 5 – Fifth Wheel Intended Use	6
Section 6 – Fifth Wheel Non-Intended Use...	6
Section 7 – Coupling Preparation	6
Section 8 – Coupling Procedures	8
Section 9 – Uncoupling Procedures	11
Section 10 – Positioning Sliding Fifth Wheels	13
Section 11 – Fifth Wheel Maintenance	15

Contents	Page
Section 12 – Top Plate Removal	16
Section 13 – Fifth Wheel Lubrication	18
Section 14 – Slide Base Lubrication.....	20
Section 15 – Fifth Wheel Adjustment	22
Section 16 – Slide Base Adjustment (Traditional Sliders Only)	25
Section 17 – Upshock Cushions, Pocket Inserts and Brackets Inspection	26
Section 18 – Top Plate Installation	28
Section 19 – Troubleshooting	29
Section 20 – Rebuild and Replacement Kits..	32

Introduction

This manual provides the information necessary for the proper operation and maintenance of HOLLAND® FW17/XA-171 Series Fifth Wheels.

Read this manual before using or servicing this product and keep it in a safe location for future reference. Updates to this manual, which are published as necessary, are available on the internet at www.safholland.us.

When replacement parts are necessary, SAF-HOLLAND® requires the use of ONLY SAF-HOLLAND Original Parts. A list of technical support locations that supply SAF-HOLLAND Original Parts and an Aftermarket Parts Catalog are available on the internet at www.safholland.us or contact Customer Service at 888-396-6501.

Notes, Cautions, and Warnings

Before starting work on any SAF-HOLLAND fifth wheel assembly, read and understand all the safety procedures presented in this manual. This manual contains the terms “NOTE,” “IMPORTANT,” “CAUTION,” and “WARNING” followed by important product information. These terms are defined as follows:

NOTE: Includes additional information to enable accurate and easy performance of procedures.

IMPORTANT: Includes additional information that, if not followed, could lead to hindered product performance.

CAUTION Used without the safety alert symbol, indicates a potentially hazardous situation which, if not avoided, could result in property damage.

CAUTION Indicates a potentially hazardous situation which, if not avoided, could result in minor or moderate injury.

WARNING Indicates a potentially hazardous situation which, if not avoided, could result in death or serious injury.

1. General Safety Instructions

- Read and observe all Warning and Caution hazard alert messages. The alerts provide information that can help prevent serious personal injury, damage to components, or both.

⚠ WARNING Failure to follow the instructions and safety precautions in this manual could result in improper servicing or operation leading to component failure which, if not avoided, could result in death or serious injury.

- All fifth wheel installation and maintenance **MUST** be performed by a properly trained technician using proper/special tools, and safety procedures.

NOTE: In the United States, workshop safety requirements are defined by federal and/or state Occupational Safety and Health Act (OSHA). Equivalent laws could exist in other countries. This manual is written based on the assumption that OSHA or other applicable employee safety regulations are followed by the location where work is performed.

IMPORTANT: Prior to operation of the fifth wheel, verify that the fifth wheel has been properly installed on the vehicle.

⚠ WARNING Failure to properly install the fifth wheel could result in tractor-trailer separation which, if not avoided, could result in death or serious injury.

IMPORTANT: These instructions apply to the proper operation of FW17/XA-171 Series Fifth Wheel top plates **ONLY**. There are other important checks, inspections, and procedures not listed here that are necessary, prudent, and/or required by law.

- For proper installation procedures, refer to Installation Manual (Document No. XL-FW10008BM-en-US), available on the internet at www.safholland.us.

⚠ WARNING Failure to follow all the operating procedures contained in these instructions could result in a hazardous condition or cause a hazardous condition to develop which, if not avoided, could result in death or serious injury.

2. Model Identification

The fifth wheel serial tag is located on the left side of the fifth wheel top plate near the pickup ramps (**Figure 1**).

The fifth wheel model number and serial number are listed on the tag (**Figure 2**).

3. Generation Identification

Determining the generation model of the fifth wheel is necessary for certain maintenance procedures and selecting the appropriate rebuild and replacement kits.

Use the criteria below to identify the generation of your fifth wheel:

1. Generation 2 fifth wheels are equipped with a front lock insert and have narrow, flat ears (**Figure 3**).
2. Generation 1 fifth wheels are not equipped with a front lock insert and have rounded ears (**Figure 4**).

Figure 1

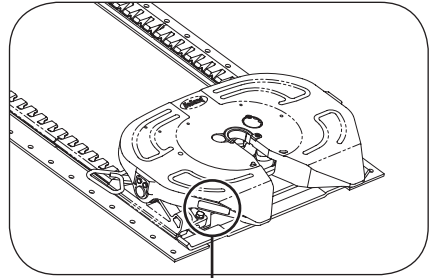

Figure 2

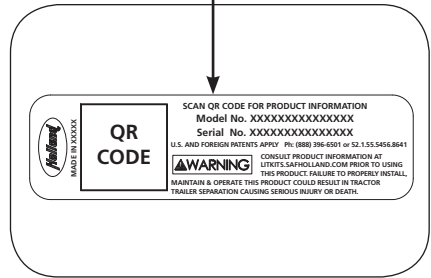

Figure 3

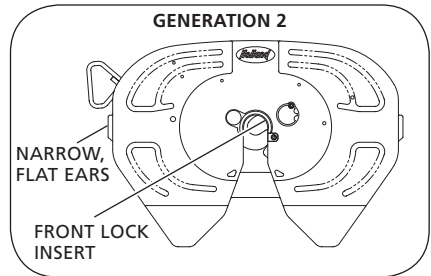
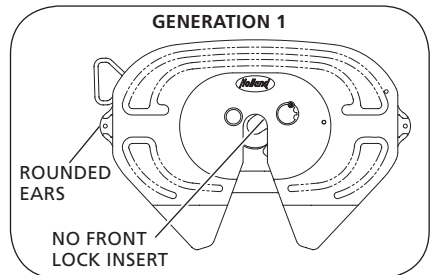

Figure 4



4. Decal Requirements

Decal XL-FW352 (**Figure 5**) enclosed in the plastic bag with the Owner's Manual, **MUST** be installed near the fifth wheel and easily viewed by the operator. Place the decal on a flat surface such as the frame rail or on the back of the cab (**Figure 6**).

NOTE: Ensure that the surface is clean (free of oil and grease) before applying the decal.

It is the responsibility of the end user to periodically inspect the decal and ensure that it is clean and completely legible. If the label is missing, loose, damaged or difficult to read, contact SAF-HOLLAND Customer Service at 888-396-6501 to order replacements immediately.

Figure 5

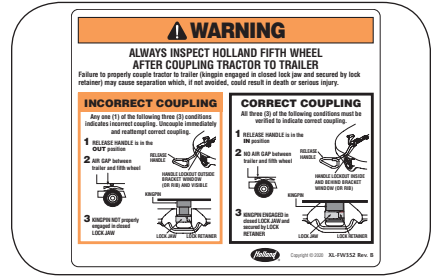
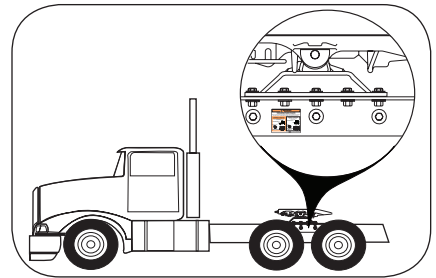

Figure 6



5. Fifth Wheel Intended Use

1. Pulling trailers with 2-inch diameter SAE-compliant kingpins which are in good condition and securely mounted to the trailer.
2. Transporting loads that are within the maximum fifth wheel rated capacities:
 - 50,000 lbs. Maximum Vertical Load on Fifth Wheel
 - Less than 95,000 lbs Gross Combination Weight (GCW)
3. In on-road applications ONLY.

IMPORTANT: SAF-HOLLAND definition of "on-road" refers to 100% maintained concrete or asphalt roads.

4. Approved applications:
 - Van Trailers
 - Tanker & Dry Bulk Trailers
 - Flatbed, Stretch & Pole Trailers
 - B-Trains (Van, Flatbed & Stretch Trailers only)
 - Converter Dollies
5. For additional details, refer to the SAF-HOLLAND Fifth Wheel Catalog & Specification Guide (Document No. XL-FW10066SG-en-US), available on the internet at www.safholland.us.

6. Fifth Wheel Non-Intended Use

1. Operating with a non-SAE compliant kingpin, such as kingpins which are bent, have improper size or dimensions, are not properly secured, or are installed on warped trailer bolster plates.

WARNING Failure to couple with a SAE compliant kingpin could result in improper coupling, allowing tractor-trailer separation, which, if not avoided, could result in death or serious injury.

2. Operating with upper coupler and fifth wheel lube plates that do not maintain the SAE kingpin dimensions. Refer to SAF-HOLLAND Service Bulletin (Document No. XL-SB004-01), available on the internet at www.safholland.us, for more information on fifth wheel lube plates.

WARNING Failure to couple with a SAE compliant kingpin could result in improper coupling, allowing tractor-trailer separation, which, if not avoided, could result in death or serious injury.

3. Tow-away operations which damage or interfere with the proper operation of the fifth wheel.
4. The attachment of lifting devices.
5. The transport of loads in excess of rated capacity.
6. In off-road applications.
7. Applications other than those recommended in the SAF-HOLLAND Fifth Wheel Catalog & Specification Guide (Document No. XL-FW10066SG-en-US), available on the internet at www.safholland.us.

WARNING Use of fifth wheel in non-intended applications could result in tractor-trailer separation which, if not avoided, could result in death or serious injury.

7. Coupling Preparation

1. Prior to coupling, an inspection MUST be performed on the fifth wheel and mounting to verify the following:
 - Tighten loose fasteners.
 - Replace missing fasteners.
 - Check for missing or damaged bracket pin fasteners (both sides of the top plate).
 - Repair/replace missing, cracked or otherwise damaged components.

- Clean grease grooves if a large amount of debris is present.
- Lubricate fifth wheel-to-trailer contact surfaces, if needed.
- Inspect fifth wheel mechanism. Lubricate dry or rusty components.
- For a sliding fifth wheel, ensure that both plungers are fully engaged.
- Inspect air line connections.
- Ensure that the fifth wheel is properly positioned on the tractor to accommodate appropriate axle weight distribution. For proper positioning of the fifth wheel, refer to SAF-HOLLAND publication (Document No. XL-FW10008BM-en-US), available on the internet at www.safholland.us.

2. Ensure that the coupling area is flat, level, and clear of persons and obstacles.
3. Tilt the ramps of the fifth wheel downward (**Figure 7**).

4. Ensure that the lock is open (**Figure 8**). If the lock is closed:

- a. **Manual Release:** Slide the release handle to the left, pull it all the way out, and hook the handle catch on the handle window bracket or the rib window of the top plate casting so that the handle is retained in the open position (**Figure 9**).
- b. **Air Release:** With the tractor's parking brakes set, activate the fifth wheel air release valve until the fifth wheel locks open. Be sure to disengage the valve prior to attempting to couple with a trailer, as the valve will continue to hold the locks open until the valve is disengaged.

CAUTION

Failure to disengage the fifth wheel air release valve prior to attempting to couple with a trailer could result in property damage.

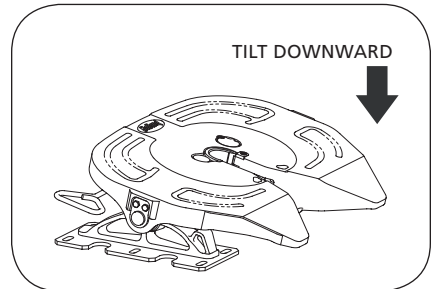
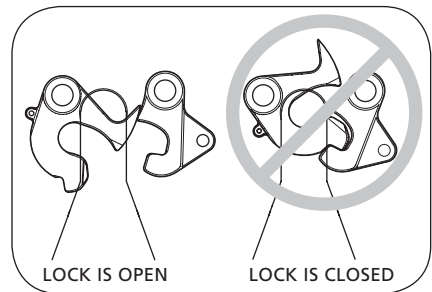
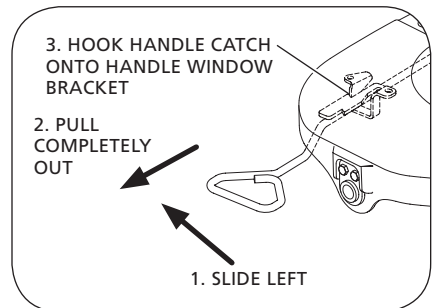
Figure 7

Figure 8

Figure 9

8. Coupling Procedures

1. Chock the trailer wheels.
2. Position the tractor so the center of the fifth wheel is aligned with the kingpin.
3. Traveling in a straight line, slowly back the tractor to the trailer. STOP the tractor before making contact with the trailer (**Figure 10**).
4. Place the tractor into neutral and set the parking brake.
5. Completely exhaust the air from the tractor suspension, ensuring that the fifth wheel is below the contact surface of the trailer (**Figure 11**).
6. Exit the cab and visually inspect that the fifth wheel is below the trailer's bolster plate. If the trailer is too low, use the landing gear to raise the trailer height.

NOTE: For proper operation of landing gear, follow the instructions published by the landing gear manufacturer.

7. Slowly back up, using the lowest gear possible. Stop when the fifth wheel is under the leading edge of the trailer (**Figure 12**).
8. Place the tractor into neutral and set the parking brake. Exit the cab and verify proper fifth wheel-to-kingpin alignment.
9. Adjust the tractor suspension until the fifth wheel top plate makes contact with the trailer's bolster plate (**Figure 13**). If the fifth wheel DOES NOT make contact with the trailer's bolster plate, use the landing gear to lower the trailer until the fifth wheel makes contact.

IMPORTANT: If the trailer is too high, the kingpin will NOT properly couple with the lock.

Figure 10

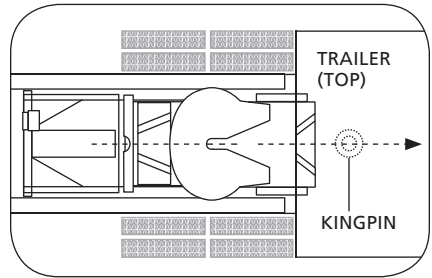

Figure 11

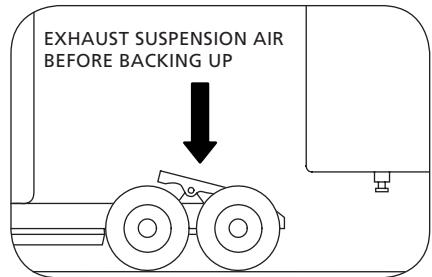

Figure 12

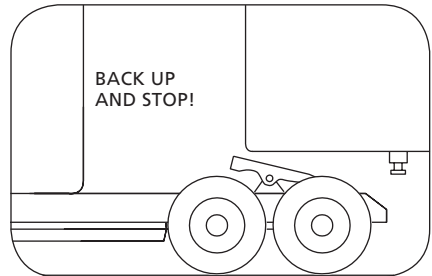
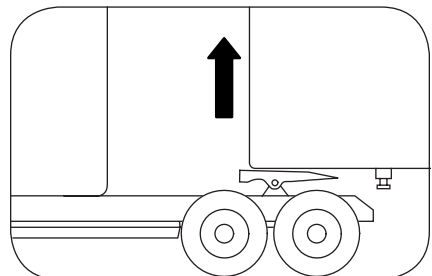

Figure 13



⚠️ WARNING Failure to couple with the trailer at the proper height could result in improper coupling, allowing tractor-trailer separation which, if not avoided, could result in death or serious injury.

IMPORTANT: NEVER inflate the tractor suspension when the kingpin is above any part of the fifth wheel.

CAUTION Failure to avoid inflating the tractor suspension when the fifth wheel is NOT forward of the kingpin, could result in damage to the kingpin and fifth wheel.

10. Slowly back into the trailer until the kingpin is coupled to the fifth wheel.
11. Place the tractor into neutral and set the parking brake.
12. Exit the cab and visually inspect for the following to ensure that the lock is closed:
 - a. Release handle fully retracted with the handle catch behind the handle window bracket or the rib window of the top plate casting (**Figure 14**).
 - b. No gap is permissible between the trailer upper coupler plate and the fifth wheel (**Figure 15**).
 - c. Lock securely closed behind the kingpin (**Figure 16**).
 - d. Lock retainer securing lock (**Figure 16**).
13. Connect the air and electrical lines.
14. Raise the landing gear legs until the pads are just above the ground.
15. Perform a pull test by locking the trailer brakes and pulling forward with the tractor to ensure that tractor-trailer separation DOES NOT occur (**Figure 17**).

Figure 14

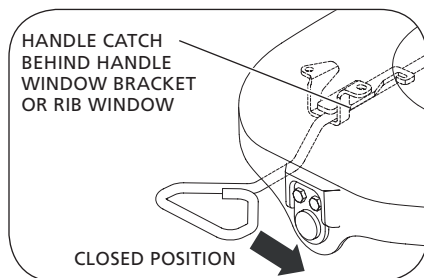

Figure 15

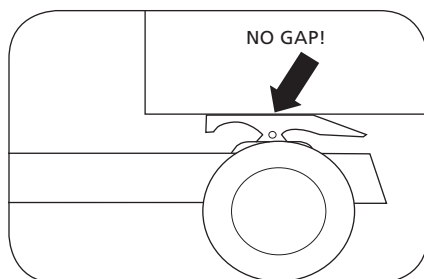

Figure 16

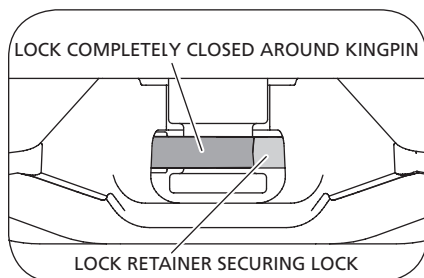
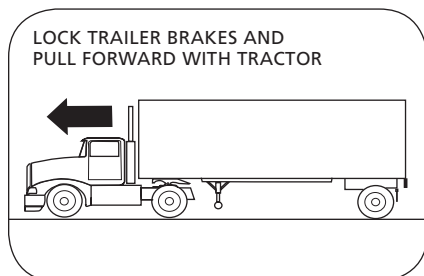

Figure 17



16. If proper coupling has NOT been achieved, repeat the coupling procedure.

⚠ WARNING Failure to properly couple the tractor and trailer could result in tractor-trailer separation while in use which, if not avoided, could result in death or serious injury.

IMPORTANT: DO NOT use any fifth wheel that fails to operate properly.

⚠ WARNING Failure to repair a malfunctioning fifth wheel before use could result in tractor-trailer separation which, if not avoided, could result in death or serious injury.

17. Fully retract the landing gear legs off the ground and secure the crank handle (**Figure 18**).

NOTE: For proper operation of landing gear, follow the instructions published by the landing gear manufacturer.

18. Remove the wheel chocks and continue with the pre-trip inspection.
19. Adjust air suspension to proper ride height.

Figure 18

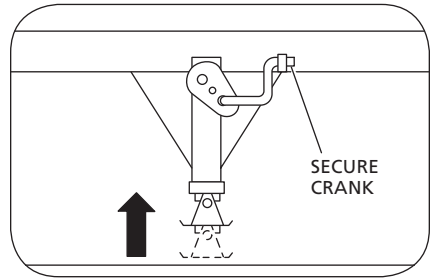

9. Uncoupling Procedures

1. Position the tractor and trailer, in straight alignment, on firm, level ground clear of obstacles and persons.
2. Set the trailer brakes.
3. Place the tractor into neutral and set the parking brake.

IMPORTANT: DO NOT exhaust air from the tractor suspension before uncoupling.

CAUTION

Failure to avoid exhausting air from the tractor suspension before uncoupling could result in difficulty uncoupling the tractor from the trailer which, if not avoided, could result in damage to the fifth wheel and kingpin.

4. Chock the trailer wheels.
5. Lower the landing gear until the pads just touch the ground (**Figure 19**).

NOTE: For proper operation and ability to transfer the trailer weight from the fifth wheel, follow the instructions published by the landing gear manufacturer. DO NOT raise the trailer off of the fifth wheel.

6. Disconnect the air and electrical lines from the trailer and secure to the tractor.
7. Slide the release handle to the left, pull it all the way out, and hook the handle catch on the handle window bracket or the rib window of the top plate casting so that the handle is retained in the open position (**Figure 20**). If equipped with air release, activate the fifth wheel air release valve until the locking mechanism opens and locks into place.

Figure 19

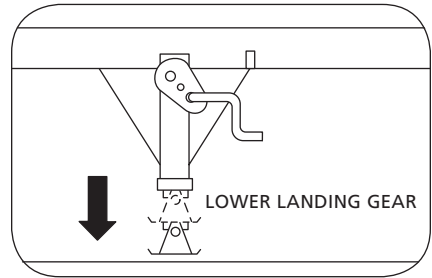
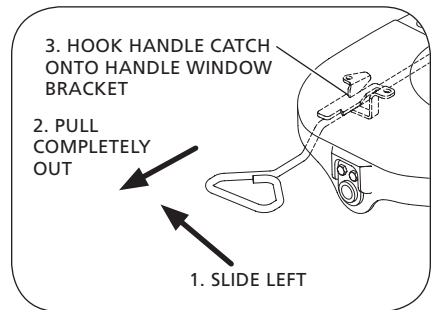

Figure 20



- Release the tractor parking brake and slowly pull forward approximately 18" (457 mm) to disengage the kingpin from the fifth wheel. The fifth wheel should be between the front edge of the trailer and the kingpin (**Figure 21**).

IMPORTANT: DO NOT drive the tractor free of the trailer.

- Place the tractor into neutral and set the parking brake. Completely exhaust the air from the tractor suspension, ensuring that the fifth wheel is below the contact surface of the trailer (**Figure 22**).
- Visually inspect uncoupling. Ensure that the trailer is completely supported by the landing gear.
- Release the tractor parking brake and slowly pull away from the trailer.
- Apply air to the tractor air suspension and allow the suspension to return to ride height (**Figure 23**).

Figure 21

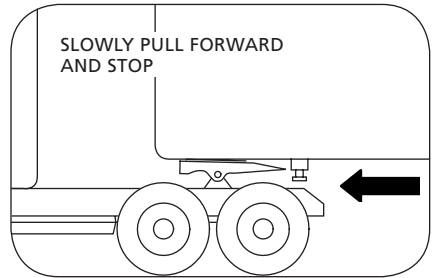

Figure 22

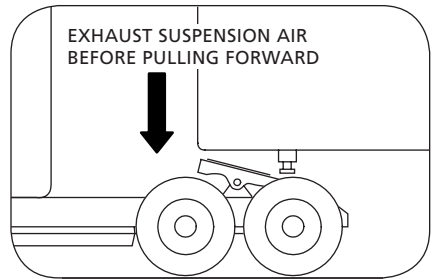
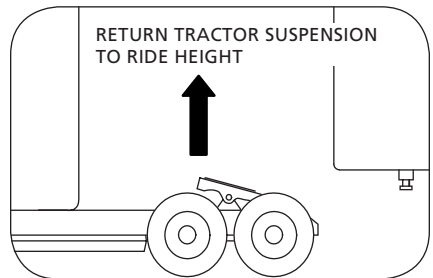

Figure 23



10. Positioning Sliding Fifth Wheels

WARNING NEVER reposition a sliding fifth wheel while the tractor-trailer is in motion or on public roads. Failure to avoid could cause loss of vehicle control or tractor-trailer separation which, if not avoided, could result in death or serious injury.

1. Position the tractor and trailer, in straight alignment, on firm, level ground clear of obstacles and persons.
2. Place the tractor into neutral and set the tractor and trailer parking brakes.

CAUTION Failure to stop and properly lock the tractor and trailer brakes could cause uncontrolled sliding of the fifth wheel which, if not avoided, could result in component damage to the tractor or trailer.

3. Release the slide locking plungers by moving the cab switch to the unlock position (**Figure 24**). If equipped with manual slide release (Traditional Sliders only), pull the release lever. If the plungers DO NOT come out, relieve pressure on the fifth wheel by using the landing gear to slightly raise the trailer. This will allow the fifth wheel to slide easier.

NOTE: Cab switch style may differ by OEM.

NOTE: For proper operation of landing gear, follow the instructions published by the landing gear manufacturer.

4. Visually inspect and verify that the plungers are disengaged.
 - **Figure 25** - ILS Sliders
 - **Figure 26** - Traditional Sliders

Figure 24

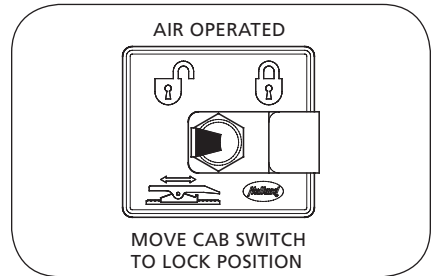

Figure 25

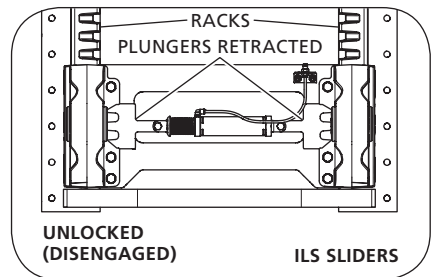
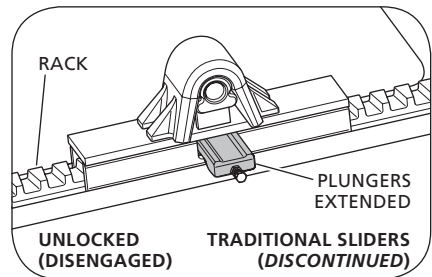

Figure 26



5. Release the tractor parking brake while keeping the trailer brakes engaged.
6. Slowly drive the tractor forward or backward to position the fifth wheel. Stop the tractor at the desired position.
7. Re-engage the slide locking plungers by moving the cab switch to the lock position (**Figure 27**). If equipped with manual slide release (Traditional Sliders only), pull the release arm to allow the plungers to retract.
8. Place the tractor into neutral and set the parking brake.
9. Visually inspect the plungers to ensure proper engagement.
 - **Figure 28** - ILS Sliders
 - **Figure 29** - Traditional Sliders
10. Retract the landing gear legs and secure the crank handle.
11. Verify that the slide locking plungers have been re-engaged by performing a pull test (**Figure 30**).

Figure 27

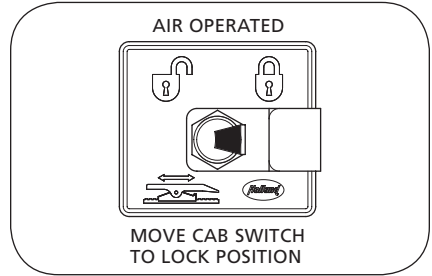

Figure 28

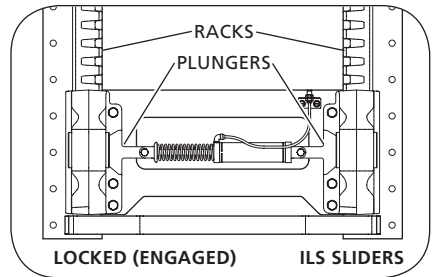

Figure 29

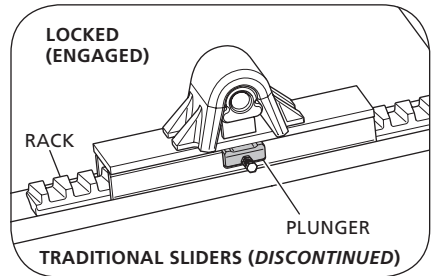
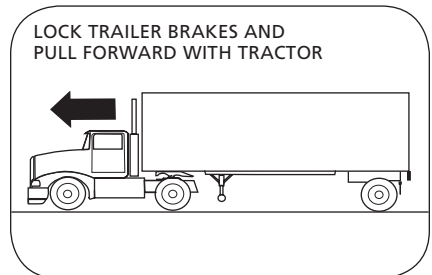

Figure 30



IMPORTANT: DO NOT operate the vehicle if the plungers are NOT fully engaged (locked).

⚠ WARNING Failure to properly engage the plungers and slide base could cause loss of vehicle control which, if not avoided, could result in death or serious injury.

11. Fifth Wheel Maintenance

IMPORTANT: All maintenance MUST be performed by a properly trained technician using proper tools and safety procedures.

IMPORTANT: All maintenance MUST be performed while the tractor is uncoupled from the trailer.

⚠ WARNING Failure to properly maintain the fifth wheel could result in tractor-trailer separation which, if not avoided, could result in death or serious injury.

1. For steps required for fifth wheel maintenance, refer to Step 1 of Section 7 and all steps in Sections 12 through 18.

NOTE: Removal of the fifth wheel top plate is NOT required for maintenance but may be required when performing repairs.

12. Top Plate Removal

IMPORTANT: FW17 fifth wheel assemblies have replaceable pocket inserts installed between the fifth wheel top plate and mounting base. When removing the top plate, the pocket inserts will either remain inside of the top plate pockets, on top of the mounting bracket caps, or may fall out. Take care NOT to lose the pocket inserts.

CAUTION Failure to prevent pocket inserts from falling out of the top plate could cause a potentially hazardous situation which, if not avoided, could result in minor or moderate injury.

For Generation 2 Fifth Wheels:

1. Remove the bracket pin retention bolts from both sides of the fifth wheel top plate (**Figure 31**).
2. Using a pry bar, pull the bracket pins out of the fifth wheel top plate (**Figure 31**).
3. Using a lifting device capable of lifting 500 lbs. (227 kg), remove the top plate from the mounting base. Place the fifth wheel upside down on a flat, clean working area.

NOTE: Follow the instructions published by the lifting device manufacturer for proper operation of the lifting device.

Figure 31

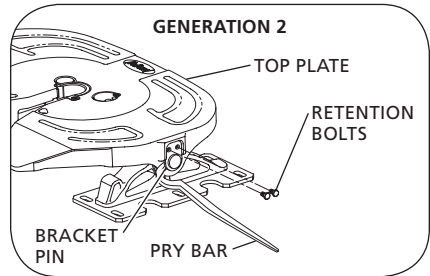

For Generation 1 Fifth Wheels:

1. Remove the bracket pin retention bolts and nuts from both sides of the fifth wheel top plate and discard (**Figure 32**).
2. Using a pry bar, pull the bracket pins out of the fifth wheel top plate and set aside (**Figure 32**).
3. Using a lifting device capable of lifting 500 lbs. (227 kg), remove the top plate from the mounting base. Place the fifth wheel upside down on a flat, clean working area.

NOTE: Follow the instructions published by the lifting device manufacturer for proper operation of the lifting device.

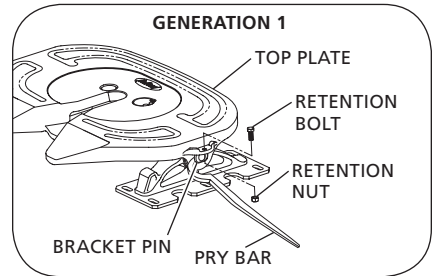
Figure 32

13. Fifth Wheel Lubrication

IMPORTANT: Fifth wheel lubrication is necessary to get the maximum service life from the FW17 series fifth wheel. Perform the following procedures at the intervals listed.

- Lubricate the locking mechanism every three (3) months or 30,000 miles.
- Thoroughly clean the locking mechanism every six (6) months or 60,000 miles.

IMPORTANT: For fifth wheels that operate in snowy or icy winter conditions, lubrication should be performed every spring in addition to routine lubrication (as noted above) to ensure optimum operation.

13.A Proper Lubrication Method

IMPORTANT: It is necessary to clean component surfaces prior to lubrication to ensure product performance.

1. Remove old grease and debris from all fifth wheel-to-trailer contact surfaces. Apply new water-resistant lithium-based grease to all fifth wheel-to-trailer contact surfaces (**Figure 33**).
2. Using water-resistant lithium-based grease, lubricate the (A) swing lock-to-hook contact areas, (B) lock area where contact is made with the kingpin, and (C) cam track (**Figure 34**).
3. Using a light oil, lubricate the (D) hook pin, and the (E) release handle pivot point. (**Figure 34**).
4. Spray light oil on the (F) cam roller (**Figure 34**).

Figure 33

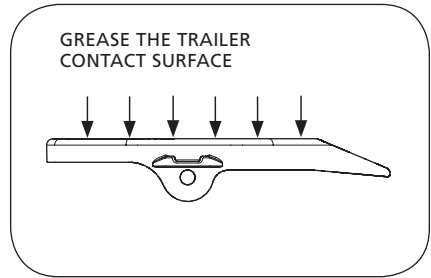
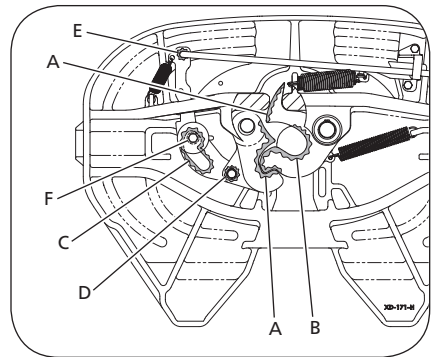

Figure 34



If equipped with air release, follow Steps 5-10 for lubrication of the air cylinder.

5. Inspect the air cylinder tube and shaft for dents, bending, or other damage and replace as necessary.
6. Activate the air cylinder control to extend the air cylinder shaft to its full travel length (**Figure 35**).
7. Clean the exposed air cylinder shaft with penetrating oil and a clean shop towel.

IMPORTANT: DO NOT use any abrasives on the exposed shaft as they could cause damage that could lead to poor air cylinder performance.

8. De-activate the air cylinder.
9. Remove the supply air line and add two to four (2-4) drops of air tool oil to the cylinder through the supply fitting. Reinstall the supply air line (**Figure 36**).
10. Activate and de-activate the air cylinder two to three (2-3) times to work the air tool oil into the cylinder and onto the shaft and verify proper operation.

13.B As-Needed Lubrication

- Maintain lubrication on fifth wheel-to-trailer contact surfaces using a water-resistant lithium-based grease. Clean crease grooves if a large amount of debris is present (**Figure 37**).
- Clean and lubricate the locking mechanism if operational difficulties arise during the service life of the fifth wheel (i.e., problems with coupling, uncoupling, or pulling the release handle) (**Figure 38**).

Figure 35

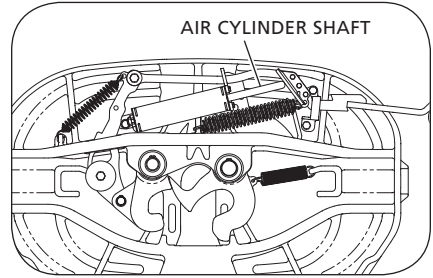

Figure 36

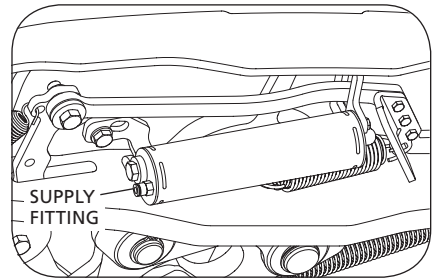

Figure 37

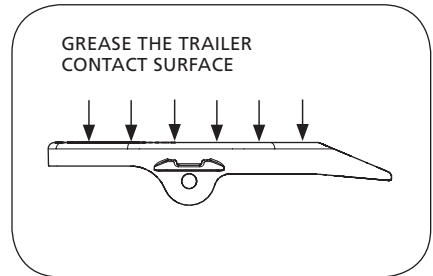
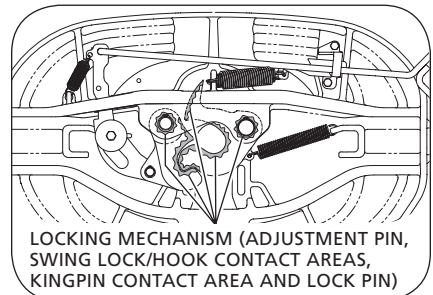

Figure 38



14. Slide Base Lubrication

NOTE: Slide base should be moved fore and aft at least once a year to maintain optimum performance.

IMPORTANT: If equipped with air release, lubricate the air cylinder every three (3) months or 30,000 miles, whichever comes first.

IMPORTANT: It is necessary to clean slide base components prior to lubrication to ensure product performance.

ILS (Integrated Low-Weight) Sliders:

1. Spray the spring-covered air cylinder shaft thoroughly with penetrating oil (**Figure 39**).

IMPORTANT: DO NOT use any abrasives on the exposed shaft as they could cause damage that could lead to poor air cylinder performance.

2. Remove the supply air line and add two to four (2-4) drops of air tool oil to the cylinder through the supply fitting. Re-install the supply air line (**Figure 40**).
3. Activate and de-activate the air cylinder two to three (2-3) times to work the air tool oil into the cylinder and onto the shaft and verify proper operation.

Figure 39

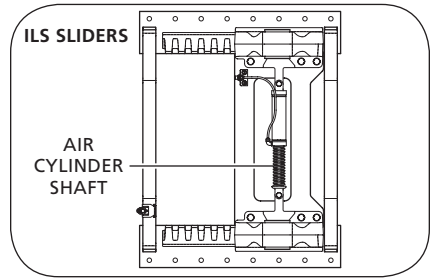
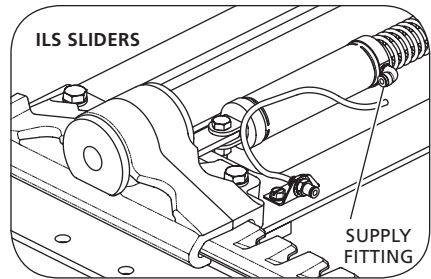

Figure 40



Traditional Sliders (discontinued):

1. With the air cylinder shaft in the exposed position, clean with penetrating oil and a clean shop towel (**Figure 41**).

IMPORTANT: DO NOT use any abrasives on the exposed shaft as they could cause damage that could lead to poor air cylinder performance.

2. Remove the supply air line and add two to four (2-4) drops of air tool oil to the cylinder through the supply fitting. Re-install the supply air line (**Figure 42**).
3. Activate and de-activate the air cylinder two to three (2-3) times to work the air tool oil into the cylinder and onto the shaft and verify proper operation.

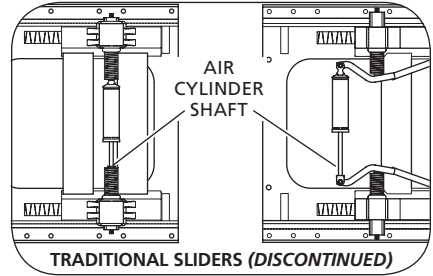
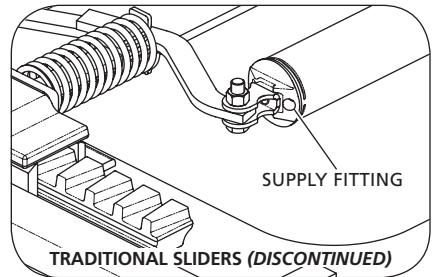
Figure 41**Figure 42**

15. Fifth Wheel Adjustment

Fifth wheel adjustments should be performed at a minimum of every 60,000 miles or if excessive movement between the kingpin and fifth wheel is noticed while driving the vehicle.

IMPORTANT: Excessive movement between the tractor and trailer can affect vehicle handling.

⚠WARNING Failure to maintain proper fifth wheel adjustment could result in loss of vehicle control which, if not avoided, could result in death or serious injury.

NOTE: To obtain proper fifth wheel adjustment, SAF-HOLLAND recommends the use of HOLLAND lock tester Part No. TF-TLN-5001, available from a local HOLLAND distributor.

1. If the fifth wheel is locked, slide the release handle to the left, pull it all the way out, and hook the handle catch on the handle window bracket or the rib window of the top plate casting so that the handle is retained in the open position (**Figure 43**). If equipped with air release, activate the fifth wheel air release valve until the locking mechanism opens and locks into place.
2. Set the lock tester on the fifth wheel top plate (**Figure 44**).
3. Push down and rotate the "J" hook on the lock tester to secure it under the front skirt of the fifth wheel top plate (**Figure 44**).

Figure 43

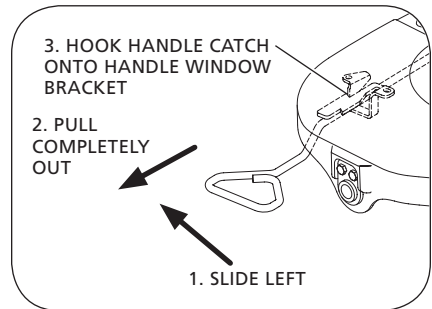
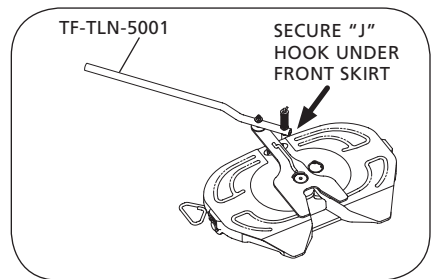
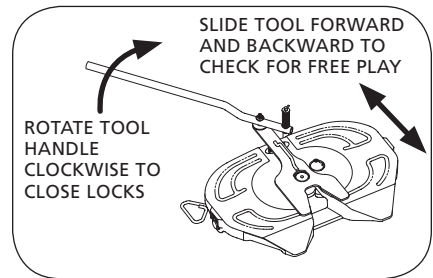
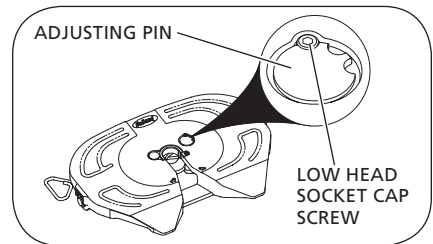
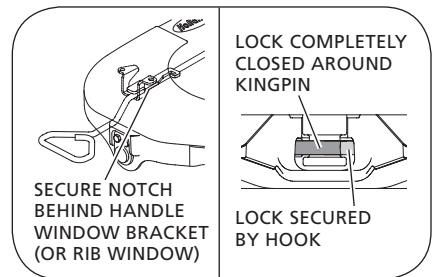

Figure 44



4. To lock the fifth wheel, rotate the handle on the lock tester clockwise until the lock closes around the kingpin (**Figure 45**).
5. Slide the lock tester forward and backward in the closed lock to check for free play between the lock and the kingpin. Ensure that the tool remains flat with full contact on the fifth wheel top plate. Use a pin gage to measure free play between the fifth wheel front lock and the kingpin. If free play exceeds 0.080" (2.03 mm), adjust the lock mechanism (**Figure 45**).
6. To adjust the lock, remove the low head socket cap screw and rotate the adjusting pin counter-clockwise until the next notch lines up with the tapped hole. Re-install the low head socket cap screw. Adjust only one notch at a time (**Figure 46**).
7. Verify proper adjustment by locking and unlocking the fifth wheel a minimum of two (2) times with the lock tester. Check that the fifth wheel is properly locked (**Figure 47**).

NOTE: To unlock the fifth wheel, slide the release handle to the left, pull it all the way out, and hook the handle catch on the handle window bracket or the rib window of the top plate casting so that the handle is retained in the open position (**Figure 43**).

Figure 45

Figure 46

Figure 47

8. Disengage the "J" hook from under the front skirt of the fifth wheel top plate (**Figure 48**).
9. Rotate the lock tester from side to side to ensure that the lock is not over-tightened. The lock should not grip the kingpin and the tool should rotate freely (**Figure 48**).
10. Re-check for free play in the lock by sliding the lock tester forward and backward using a pin gage to measure free play between the fifth wheel front lock and the kingpin (**Figure 45**). Free play should be 0.040" (1.02 mm) minimum. If free play still exceeds 0.080" (2.03 mm) in the lock, repeat the procedure and adjust one more notch.
11. Slide the release handle to the left, pull it all the way out, and hook the handle catch on the handle window bracket or the rib window of the top plate casting so that the handle is retained in the open position (**Figure 43**).
12. Push down and rotate the "J" hook on the lock tester to secure it under the front skirt of the fifth wheel top plate (**Figure 49**).
13. Pull the lock tester handle counter-clockwise to release the kingpin (**Figure 50**).
14. Disengage the "J" hook from under the front skirt of the fifth wheel top plate and remove the lock tester (**Figure 50**).

Figure 48

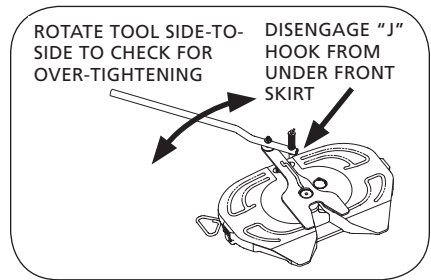

Figure 49

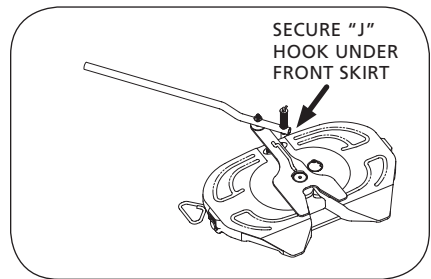
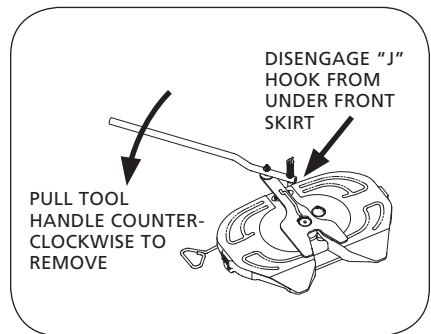

Figure 50



NOTE: If there is still excessive free play in the lock with the adjustment pin on the last (third) notch, the fifth wheel **MUST** be rebuilt using the appropriate SAF-HOLLAND service kit.

IMPORTANT: Before using your fifth wheel, you **MUST** verify that it is operating properly.

⚠ WARNING

Failure to verify that the fifth wheel is operating properly could result in loss of vehicle control which, if not avoided, could result in death or serious injury.

16. Slide Base Adjustment (Traditional Sliders Only - discontinued)

NOTE: ILS slider locking plungers DO NOT require adjustment.

Some HOLLAND slide bases are equipped with adjustable locking plungers. Adjustment should be performed at a minimum of every 60,000 miles or if excessive movement is noticed while driving the vehicle. To obtain proper adjustment, follow these procedures:

1. Loosen the lock nut and turn the adjustment bolt counterclockwise (**Figure 51**).
2. Disengage and engage the locking plungers. Verify that the locking plungers have engaged properly (**Figures 52 and 53**).
3. Tighten the adjustment bolt until it contacts the rack.
4. Turn the adjustment bolt clockwise an additional 1/2 turn, then tighten the lock nut securely.

If the locking plungers DO NOT release fully to allow the fifth wheel to slide:

- Check the air cylinder for proper operation. Replace if necessary.
- Check the locking plunger adjustment as explained above.
- If a locking plunger is binding in the plunger pocket, remove the locking plunger using a HOLLAND spring compressor Part No. TF-TLN-2500, available from a local HOLLAND distributor. Grind the top edges of the locking plunger 1/16" (1.5 mm) (**Figure 54**). Re-install and adjust the locking plungers as explained above.

NOTE: If problems persists, contact SAF-HOLLAND Customer Service: 888-396-6501.

Figure 51

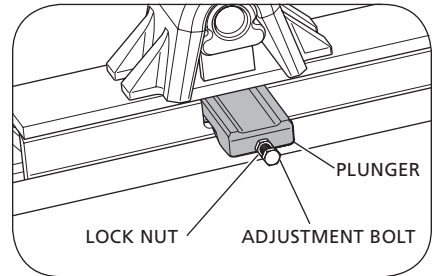

Figure 52

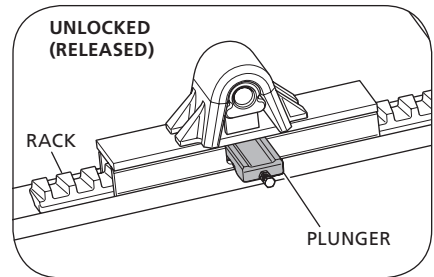

Figure 53

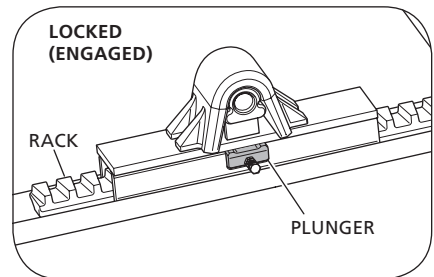
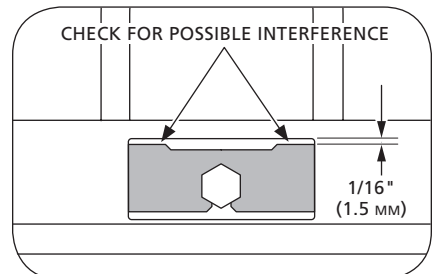

Figure 54



17. Upshock Cushions, Pocket Inserts and Brackets Inspection

To determine if upshock cushions, pocket inserts and/or brackets require replacement, pry up on the fifth wheel top plate pivot ear using a small bar (**Figure 55**). If there is more than 1/4" (6.4 mm) free vertical movement, the top plate should be removed for further inspection. (Refer to Section 12 for top plate removal instructions.)

Upshock Cushions:

1. Standard Cushion (**Figure 56**):

Replace if:

- The hole is elongated to more than 1-3/8" (34.9 mm).
- The upshock cushions are cracked, cut or otherwise severely damaged.

2. ILS-Style Cushion (**Figure 57**):

Replace if:

- The hole is elongated to more than 1-1/2" (38.1 mm).
- The upshock cushions are cracked, cut or otherwise severely damaged.

Figure 55

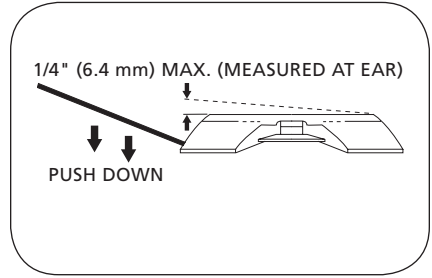

Figure 56

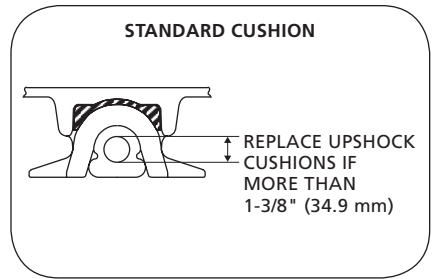
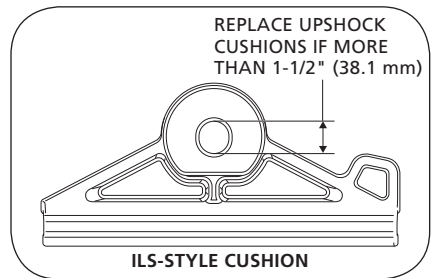

Figure 57



Pocket Inserts (Figure 58) :

Replace if:

- The thickness of the pocket insert is 1/16" (1.6 mm) or less.
- The pocket inserts are severely chipped, cracked or gouged.

Brackets:

1. Standard Bracket (Figure 59) and ILS-Style Bracket (Figure 60):

Replace if:

- The thickness of the bracket cap at the top is less than 3/8" (9.5 mm) when measured approximately 1/4" (6.4 mm) in from the edge.
- The brackets are gouged, cracked or otherwise severely damaged.

Figure 58

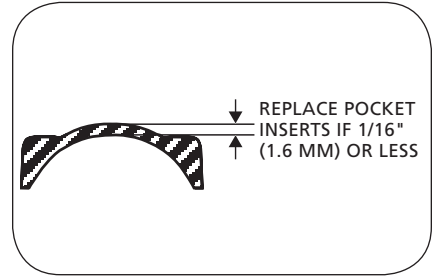

Figure 59

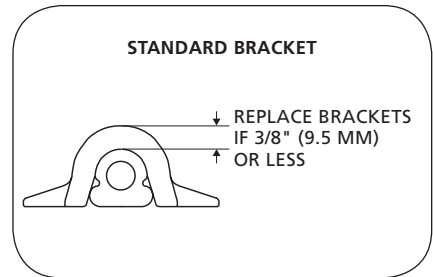
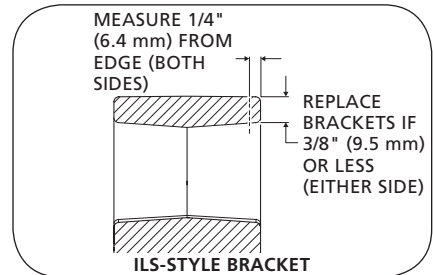

Figure 60



18. Top Plate Installation

1. If the pocket inserts are dislodged from the fifth wheel casting, clean the pocket areas of the casting and apply a strip of double-face tape into the bottom of each pocket. Install the pocket inserts by pressing them down firmly into the pocket areas (**Figure 61**).
2. Using a lifting device capable of lifting 500 lbs. (227 kg), install the fifth wheel top plate onto its mounting base.

NOTE: Follow the instructions published by the lifting device manufacturer for proper operation of the lifting device.

3. **For Generation 2 Fifth Wheels:** Install the bracket pins through the fifth wheel top plate casting and mounting base and secure by installing the two (2) bracket pin retention bolts through each bracket pin plate (**Figure 62**). Torque retention fasteners to 20-25 ft.-lbs. (27-34 N•m).

IMPORTANT: If bolts are re-used, apply a non-permanent thread locker to bolt threads prior to installation and tightening.

For Generation 1 Fifth Wheels: Install the bracket pins through the fifth wheel top plate casting and mounting base and secure by installing the bracket pin retention bolts and nuts to each ear of the top plate (**Figure 63**). Torque retention fasteners to 50-60 ft.-lbs. (68-81 N•m).

IMPORTANT: If bolts are re-used, apply a non-permanent thread locker to bolt threads prior to installation and tightening.

Figure 61

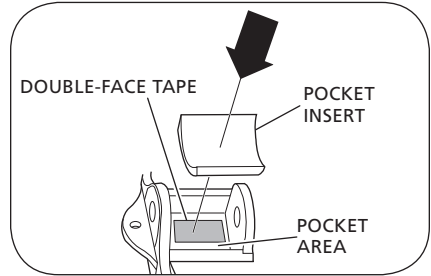

Figure 62

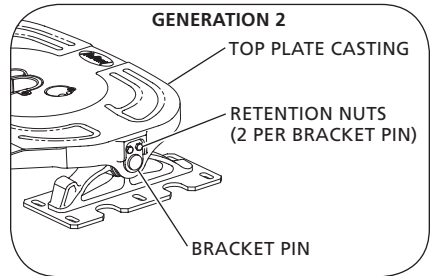
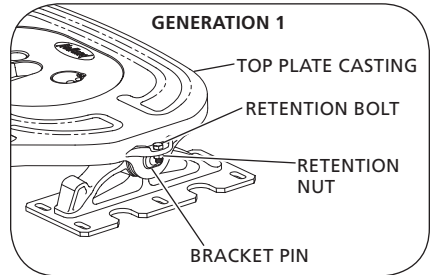

Figure 63



19. Troubleshooting

Difficult to Couple to Trailer:

✓	POSSIBLE CAUSE	SOLUTION
	Attempting to couple too fast.	Couple in accordance with the procedures in Section 8.
	The trailer may be too high; the kingpin is not entering the lock properly.	Lower the trailer in accordance with the manufacturer's instructions.
	The lock is closed.	Slide the release handle to the left and pull it all the way out until the lock swings open. If equipped with air release, activate the fifth wheel air release valve until the locking mechanism opens and locks into place.
	Accumulated rust or grime are interfering with the lock operation.	Thoroughly clean the fifth wheel and re-lubricate in accordance with the procedures in Section 13.
	The lock is adjusted too tightly.	Check lock adjustments in accordance with the procedures in Section 15.
	The lock may be damaged.	The fifth wheel MUST be rebuilt using the appropriate SAF-HOLLAND service kit.
	The air cylinder may be dry inside.	Disconnect the air line at the air cylinder and add 2-3 drops of air tool oil. Reconnect and activate air a few times. (Refer to Section 13 in this manual.)
	The release handle may be damaged or bent.	Replace the release handle using the appropriate SAF-HOLLAND service kit.
	The air cylinder tube and/or shaft (on air release-equipped fifth wheels) may be dented, bent, or otherwise damaged.	Replace the air cylinder using the appropriate SAF-HOLLAND service kit.
	The air release system on the tractor is not functioning properly.	Disconnect the air line at the air cylinder and apply shop air at 100 to 120psig. If the air release works properly, check the truck system, including the air lines and control valve. The air flow into and out of the air cylinder should meet a "Coefficient of Velocity" (CV), or Flow Factor of 0.24 or greater (15 scfm at 100psi). To ensure proper product performance, the exhaust flow must be full flow, non-restrictive/non-clogging, without any component which will act as a check valve, to ensure free flow-through exhaust in both directions.
	Bent kingpin, damaged upper coupler, or improper use of lube plates may be interfering with lock movement.	Check the kingpin and upper coupler plate as detailed in HOLLAND Service Bulletin XL-SB020. Repair/replace as required. Remove any improperly installed or improperly specified lube plates. Refer to HOLLAND Service Bulletin XL-SB004-01 for lube plate warnings.
	Release handle is still on the unlock notch after previous uncoupling.	Push the handle off of the unlock notch to prepare for coupling. If the handle continues to stick to the unlock notch during uncoupling, replace the release handle with SAF-HOLLAND service kit Part No. RK-171-11079-M for Generation 1 fifth wheels or service kit Part No. RK-171-12308-M for Generation 2 fifth wheels.

Difficult to Uncouple from Trailer:

✓	POSSIBLE CAUSE	SOLUTION
	The tractor is too low.	Raise the tractor suspension to the proper ride height.
	The release handle is not completely pulled out and retained on the top plate in the open position.	Slide the release handle to the left, pull it all the way out, and hook the handle catch on the handle window bracket or the rib window of the top plate casting so that the handle is retained in the open position. If equipped with air release, activate the fifth wheel air release valve until the locking mechanism opens and locks into place.
	Accumulated rust or grime are interfering with the lock operation.	Thoroughly clean the fifth wheel and re-lubricate in accordance with the procedures in Section 13.
	The lock is adjusted too tightly.	Check lock adjustments in accordance with the procedures in Section 15.
	The release handle will not stay out or must be held out when unlocking.	The fifth wheel MUST be rebuilt using the appropriate SAF-HOLLAND service kit.
	The air cylinder may be dry inside.	Disconnect the air line at the air cylinder and add 2-3 drops of air tool oil. Reconnect and activate air a few times. (Refer to Section 13 in this manual.)
	Missing or damaged release system parts.	The fifth wheel MUST be rebuilt using the appropriate SAF-HOLLAND service kit.
	The air cylinder tube and/or shaft (on air release equipped fifth wheels) may be dented, bent, or otherwise damaged.	Replace the air cylinder using the appropriate SAF-HOLLAND service kit.
	The air release system on the tractor is not functioning properly.	Disconnect the air line at the air cylinder and apply shop air at 100 to 120psig. If the air release works properly, check the truck system, including the air lines and control valve. The air flow into and out of the air cylinder should meet a "Coefficient of Velocity" (CV), or Flow Factor of 0.24 or greater (15 scfm at 100psi). To ensure proper product performance, the exhaust flow must be full flow, non-restrictive/non-clogging, without any component which will act as a check valve, to ensure free flow-through exhaust in both directions.
	Bent kingpin, damaged upper coupler, or improper use of lube plates may be interfering with lock movement.	Check the kingpin and upper coupler plate as detailed in HOLLAND Service Bulletin XL-SB020. Repair/replace as required. Remove any improperly installed or improperly specified lube plates. Refer to HOLLAND Service Bulletin XL-SB004-01 for lube plate warnings.

Excessive Movement between Fifth Wheel and Kingpin:

✓	POSSIBLE CAUSE	SOLUTION
	The fifth wheel lock requires adjustment	Follow the procedures contained in Section 15.
	The fifth wheel cannot be adjusted further.	The fifth wheel MUST be replaced or rebuilt using the appropriate SAF-HOLLAND service kit.
	The kingpin is loose	Repair the trailer.
	The kingpin is worn.	Check the kingpin for acceptable wear with HOLLAND Kingpin Gauge TF-0110. Replace the kingpin if necessary.

Difficulty in Sliding Fifth Wheel:

✓	POSSIBLE CAUSE	SOLUTION
	The trailer may be putting too much pressure down on the fifth wheel.	Lessen weight on the fifth wheel by raising the trailer with the landing gear. NOTE: For proper operation of landing gear, follow the instructions published by the landing gear manufacturer.
	The tractor is too low.	Raise the tractor suspension to the proper ride height.
	Accumulated rust or grime are interfering with the release mechanism.	Clean the mechanism and add light oil to the plunger-to-bracket contact area. Refer to Figures 25-26 and 28-29 .
	The air cylinder tube and/or shaft may be dented, bent, or otherwise damaged.	Replace the air cylinder using the appropriate SAF-HOLLAND service kit.
	The air cylinder may be dry inside.	Disconnect the air line at the air cylinder and add 2-3 drops of air tool oil. Reconnect and activate air a few times. (Refer to Section 13 in this manual.)
	The air release system from the tractor is not functioning properly.	Disconnect the air line at the air cylinder and apply shop air at 100 to 120psig. If the air release works properly, check the truck system, including the air lines and control valve. The air flow into and out of the air cylinder should meet a "Coefficient of Velocity" (CV), or Flow Factor of 0.24 or greater (15 scfm at 100psi). To ensure proper product performance, the exhaust flow must be full flow, non-restrictive/non-clogging, without any component which will act as a check valve, to ensure free flow-through exhaust in both directions.

Hard Steering or Binding:

✓	POSSIBLE CAUSE	SOLUTION
	Lack of lubrication on the fifth wheel top surface.	Lubricate the top of the fifth wheel plate using a high pressure, lithium-based grease. Follow the recommended lubrication schedule as described in Section 13.
	Warped trailer upper coupler plate.	Check the upper coupler plate for flatness and replace, if necessary. Refer to HOLLAND Service Bulletin XL-SB020.

20. Rebuild and Replacement Kits

REBUILD AND REPLACEMENT KITS	PART NUMBER	
	GEN I	GEN II
Rebuild Kit: Standard Manual Release	RK-17-A-L-H	
Rebuild Kit: Air Release	RK-17-A-80-L-H	
Lock and Hook Replacement Kit: Standard	RK-171-12305	
Lock and Hook Replacement Kit: Air Release	*RK-17-A-80	RK-171-12305
Release Cam Pivot Bolt Hardware Replacement Kit	RK-171-12306	
Release Handle Replacement Kit: Standard	RK-171-12308	
Release Handle Replacement Kit: Air Release	*RK-17-A-80	RK-171-12308-AR
Air Cylinder Replacement Kit	*RK-17-A-80	RK-171-12307
Upshock Cushions Kit for Cast Brackets (ILS-style)	RK-10605-1	RK-12311-1
Upshock Cushions Kit for Fabricated Brackets	RK-0011-2-1	RK-0012-3-1
Pocket Inserts (Pair)	RK-PKT-2	

*Generation 1 Air Release component kits are available for a limited time. If no longer available, a full rebuild kit must be purchased.

NOTE: Refer to Section 3 for Generation Identification.









From fifth wheel rebuild kits to suspension bushing repair kits, SAF-HOLLAND Original Parts are the same quality components used in the original component assembly.

SAF-HOLLAND Original Parts are tested and designed to provide maximum performance and durability. Will-fits, look-alikes or, worse yet, counterfeit parts will only limit the performance potential and could possibly void SAF-HOLLAND's warranty. Always be sure to spec SAF-HOLLAND Original Parts when servicing your SAF-HOLLAND product.

SAF-HOLLAND USA • 888.396.6501 • Fax 800.356.3929

www.safholland.us

SAF-HOLLAND CANADA • 519.537.3494 • Fax 800.565.7753

WESTERN CANADA • 604.574.7491 • Fax 604.574.0244

www.safholland.ca

SAF-HOLLAND MEXICO • 52.55.5362.8743 • Fax 52.55.5362.8743

www.safholland.com.mx

info@safholland.com

SAF-HOLLAND USA, INC.
1950 Industrial Blvd., Muskegon, MI 49442
www.safholland.com

