

Maintenance Procedures

3500 LowLube Fifth Wheel

⚠ WARNING You must read and understand the following instructions before operating your fifth wheel.

Failure to follow all of the important maintenance procedures contained in these instructions may result in a hazardous condition or cause hazardous condition to develop.

All maintenance must be performed by a qualified person using proper tools and safe procedures.

All maintenance must be performed while the tractor is uncoupled from the trailer.

As-needed Lubrication

Lubricate the cam track and pivot with a light oil or diesel oil.

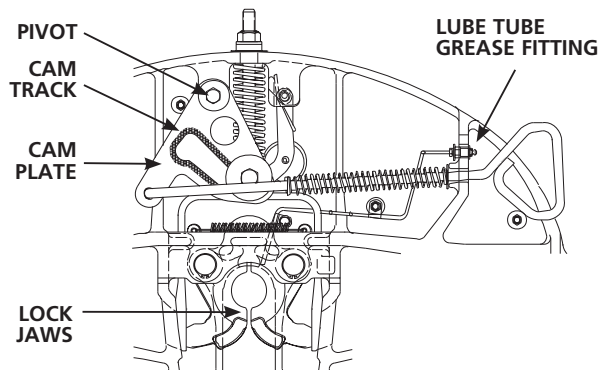

Apply grease to lock jaws and front of throat directly or through lube tube grease fitting.

On sliding fifth wheels, spray a light oil or diesel oil on the rack and slide path.

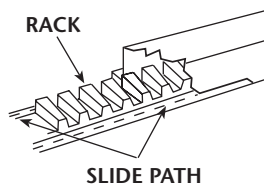

Required Inspections and Adjustments

At every regularly scheduled maintenance interval, perform a visual inspection of the lube plates to confirm that they are in place and firmly attached.

Perform the following every six months or 60,000 miles, whichever comes first. Thoroughly steam clean all components before inspecting or adjusting.

⚠ WARNING Do not use any fifth wheel which does not operate properly. If your fifth wheel does not operate properly, contact your nearest Holland representative for assistance.

General Fifth Wheel Inspection

1. Inspect fifth wheel mounting and fifth wheel assembly.
 - Confirm the lube plates are in place and firmly attached.
 - Check fastener torque
 - Replace missing or damaged bolts
 - Replace bent, worn or broken parts (Use only genuine Holland parts.)

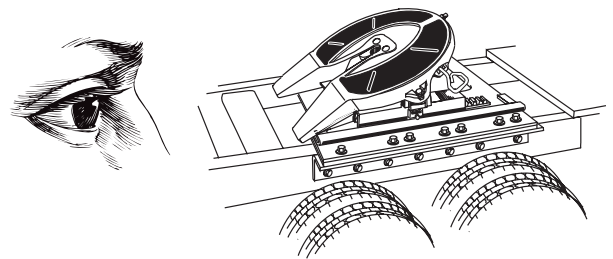

Inspection — Locking Mechanism

1. Verify operation by opening and closing locks with Holland Kingpin Lock Tester model no. TF-TLN-1000 or TF-TLN-5000.

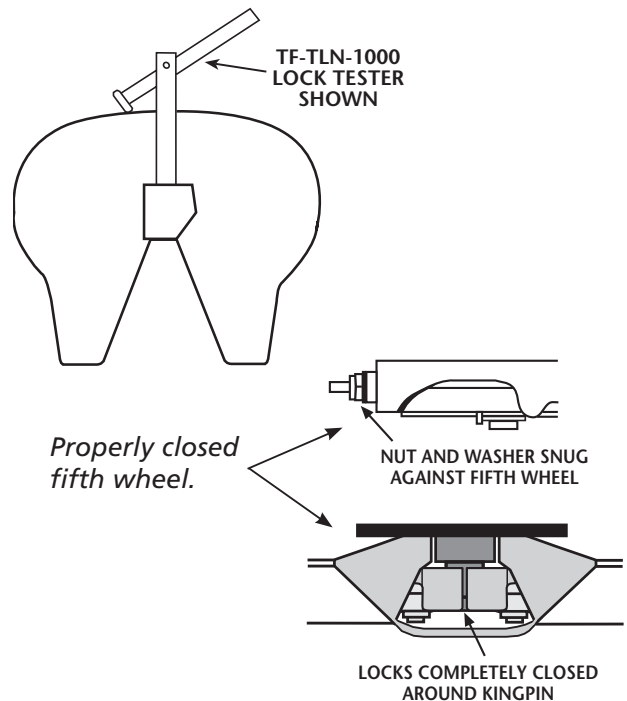

Adjustment – Locking Mechanism

1. Close locks using Holland Lock Tester.
2. Rotate rubber bushing located between the adjustment nut and casting.
3. If the bushing is tight, rotate nut on yoke shank counter-clockwise until bushing is snug, but still can be rotated.
4. Verify proper adjustment by locking and unlocking with the lock tester.

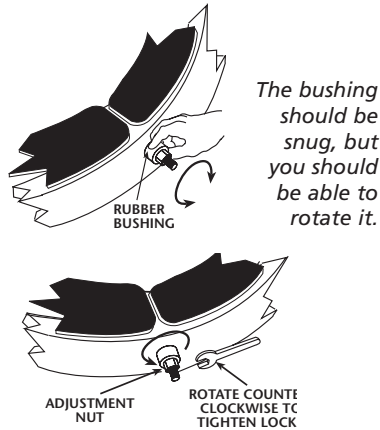

Adjustment – Fifth Wheel Slide Mechanism

1. Loosen lock nut and turn adjustment bolt out (counter-clockwise).

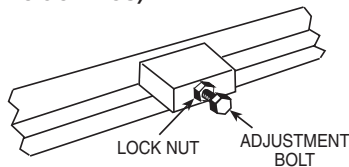

2. Disengage and engage the locking plungers. Verify that plungers have seated properly as shown.

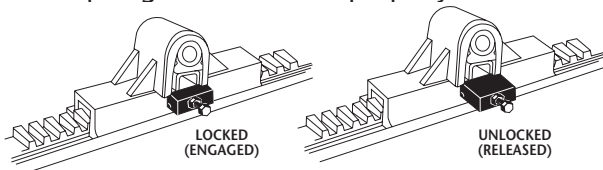

3. Now tighten adjustment bolt until it contacts the rack.
4. Turn the adjustment bolt clockwise an additional 1/2 turn then tighten the lock nut securely.

CAUTION Proper adjustment of the sliding bracket locking plungers must be performed at installation and maintained at regular intervals using the adjustment bolts for both plungers. Proper adjustment is required for proper operation, load transfer and load distribution.

5. If plungers do not release fully to allow fifth wheel to slide:
 - A. Check the air cylinder for proper operation. Replace if necessary.
 - B. Check plunger adjustment, as explained above.
 - C. If a plunger is binding on the plunger pocket, remove the plunger using a Holland TF-TLN-2500 spring compressor. Grind the top edges of the plunger 1/16" as shown. Re-install and adjust the plungers, as explained above.

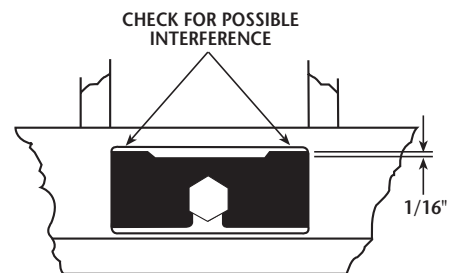

6. If the locking plungers are too loose:
 - A. Check plunger adjustment, as explained above.
 - B. Check plunger springs for proper compression. Replace if necessary.
 - C. Check for plunger wear. If necessary, replace, as described above.

After inspection and adjustment, relubricate all moving parts with a light, rust resistant oil.