

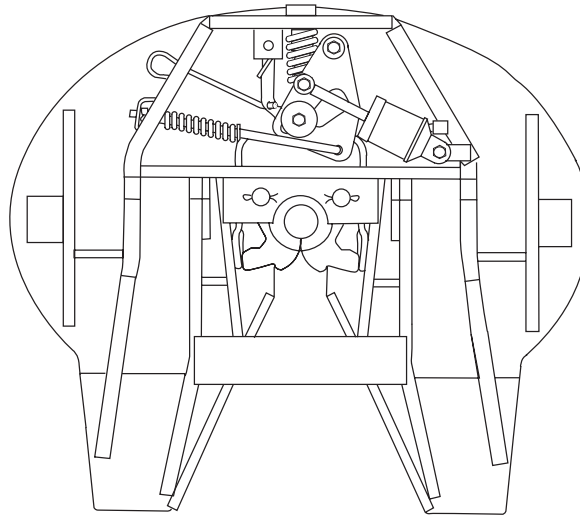

Maintenance Procedures for **XA-2801 Series** Fifth Wheel Top Plates



TROUBLE SHOOTING HINTS:

FIFTH WHEEL IS HARD TO HOOK UP TO TRAILER:

CK'D	POSSIBLE CAUSE	REMEDY
<input type="checkbox"/>	The fifth wheel may be too low; the kingpin is not entering the locks properly.	Raise the fifth wheel until it contacts the bolster plate.
<input type="checkbox"/>	Locks are closed.	Push and hold the air control valve (XB-2556) to keep the locks open.
<input type="checkbox"/>	Accumulated rust or grime are interfering with lock operation.	Spray a light lubricant or diesel fuel on all moving parts and operate several times.
<input type="checkbox"/>	Bent kingpin or damaged bolster plate may be interfering with lock movement.	Check the kingpin with a Holland TF-0110 kingpin gage and bolster plate with a 48" straight edge.
<input type="checkbox"/>	The locks may be damaged.	Inspect and replace, if required.
<input type="checkbox"/>	The fifth wheel may need rebuilding.	Rebuild the fifth wheel with RK-65021 rebuild kit.

FIFTH WHEEL IS HARD TO UNHOOK FROM TRAILER:

CK'D	POSSIBLE CAUSE	REMEDY
<input type="checkbox"/>	The secondary lock is not released.	Inspect secondary lock for missing or broken parts and repair or replace as required. Inspect air line and air cylinder for restrictions.
<input type="checkbox"/>	The tractor may be putting pressure against the locks.	Back the tractor into the trailer to relieve pressure. Lock the tractor brakes. Push and hold air control valve (XB-2556), release tractor brakes and move the tractor forward.
<input type="checkbox"/>	Rust or grime on lock mechanism.	Spray a light lubricant or diesel fuel on all moving parts and operate several times.
<input type="checkbox"/>	Bent kingpin or damaged bolster plate.	Check the kingpin with a Holland TF-0110 kingpin gage and bolster plate with a 48" straight edge. Repair or replace as required.

GENERAL INFORMATION:

1. All fifth wheel maintenance and rebuilding must be performed by a qualified person using proper tools and safe procedures.
2. Do not modify or add to the product.
3. Wear safety goggles during installation, removal and rebuilding.
4. Never strike any part of the item with a steel hammer.
5. Do not weld on this product without written permission from the factory.
6. Observe standard precautions when lifting.
7. Refer to Holland Publication FW 130 for description and instructions for Holland TF-TLN-1000 Kingpin Lock Tester.
8. Do not deviate from these instructions. Any changes or deviations will void all warranties, expressed or implied, unless written consent is first obtained from the factory.

WARNING: DO NOT USE ANY FIFTH WHEEL THAT DOES NOT OPERATE PROPERLY.

These products are covered by Holland's Commercial Products Warranty. Holland reserves the right, without giving prior notice, to change specifications and dimensions as designs are altered or improved.

**TOP PLATE
REBUILD KIT
NO. RK-65021**

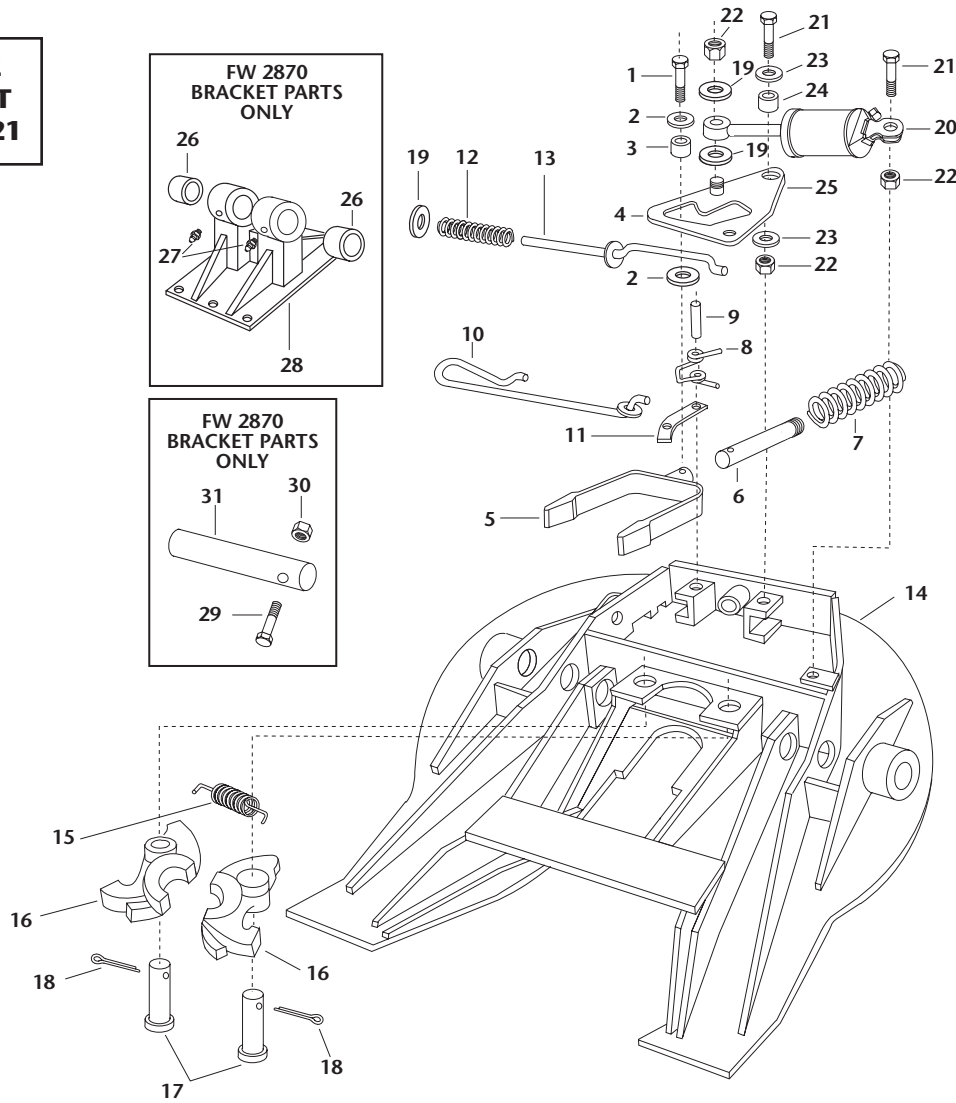

ITEM	PART NO.	NO. REQ'D	DESCRIPTION	ITEM	PART NO.	NO. REQ'D	DESCRIPTION	ITEM	PART NO.	NO. REQ'D	DESCRIPTION
1	XB-CX-58-F-134	1	HHCS 5/8"-18 x 1.75"	12	XB-1028-1	1	Spring	23	XB-T-49	2	Washer
2	XB-1030-1	2	Washer	13	XA-1707-16	1	Release handle S/A	24	XA-1029	1	Roller
3	XA-1507-1	1	Cam roller	14	XA-2801	1	FW top plate	25	XB-01996	1	90 deg. elbow
4	XA-1705-11	1	Cam plate	15	XB-GT-13-1	1	Spring	26	XA-0861	4	Bearing
5	XA-1703-F	1	Yoke	16	XA-1704-X	1	Lock set	27	XB-H-38	4	Grease zerk
6	XA-1706-1	1	Yoke shaft	17	XA-1313	2	Lock pin	28	XA-03193	2	Bracket
7	XB-1505	1	Spring	18	XB-5	2	Cotter pin	29	XB-BR-12-C-4	2	HHCS 1/2"-13 x 4"
8	XB-2149	1	Torsion spring	19	XB-PW-1732-1-116	3	Washer	30	XB-0103	2	Locknut
9	XB-21-S-500-2750	1	Roller pin	20	XA-2524-R-13-X	1	Air cylinder	31	XA-2809	2	Pivot shaft
10	XA-3544-1-A	1	Secondary lock handle	21	XB-2083	2	HHCS 1/2"-20 x 1.75"				
11	XA-3528	1	Secondary lock bar	22	XB-T-69-A	3	Locknut				

MAINTENANCE OF XA-2801 SERIES FIFTH WHEELS:

The following procedures must be performed as necessary to maintain proper operation.

1. Lubricate all moving parts with No. 2 diesel oil or suitable lubricant.
2. Lube fittings (28) weekly with grease.
3. Check proper operation of fifth wheel with a TF-TLN-1000 Kingpin Lock Tester. Check locking and unlocking actions.
4. Replace all cracked, missing or damaged parts using only Holland parts.
5. Lubricate fifth wheel top plate surface as required to maintain adequate lubrication.

Copyright © September 2002 • The Holland Group, Inc.

Holland USA, Inc. Facilities:

Denmark, SC Warrenton, MO
Dumas, AR Whitehouse Station, NJ
Holland, MI Wylie, TX
Muskegon, MI

Holland International, Inc.

Holland, MI
Phone: 616-396-6501
Fax: 616-396-1511

Holland Hitch of Canada, Ltd.

Woodstock, Ontario • Canada
Phone: 519-537-3494
Fax: 800-565-7753

Holland Equipment, Ltd.

Norwich, Ontario • Canada
Phone: 519-863-3414
Fax: 519-863-2398

Holland Hitch Western, Ltd.

Surrey, British Columbia • Canada
Phone: 604-574-7491
Fax: 604-574-0244