

Fifth Wheel Rebuild Procedure

XA-2801-03185 Series
Elevating Fifth Wheel Top Plate
RK-03185 Series Kits

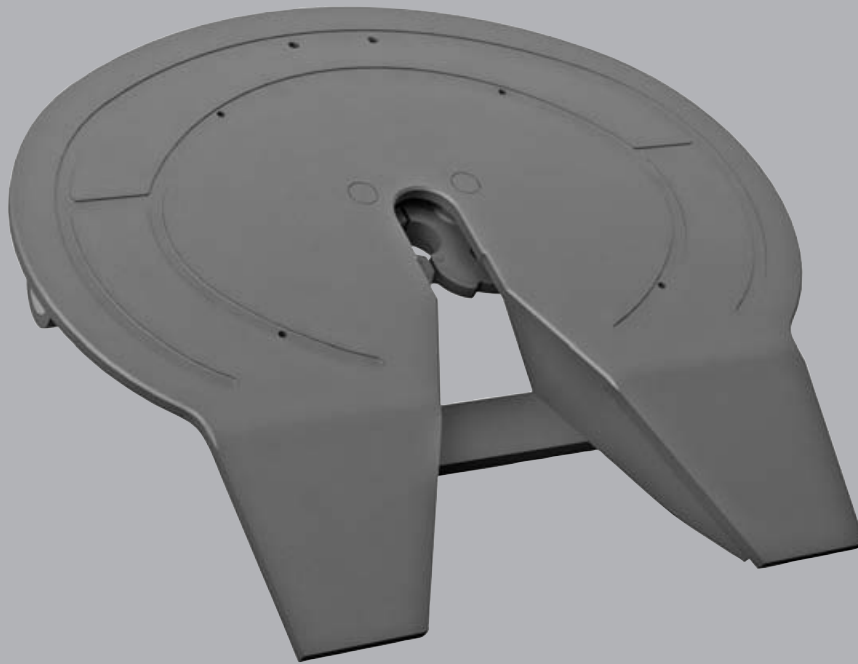

REBUILD PROCEDURE

Notes, Cautions, and Warnings

You must read and understand all of the safety procedures presented in this manual before starting any work on the SAF-HOLLAND product.

NOTE: In the United States, work shop safety requirements are defined by federal and/or state Occupational Safety and Health Act or equivalent laws in other countries. This manual is written based on the assumption that OSHA or other applicable employee safety regulations are followed by the location where work is performed.

Proper tools must be used to perform the maintenance and repair procedures described in this manual. Many of these procedures require special tools.

Throughout this manual, you will notice the terms "NOTE", "IMPORTANT", "CAUTION", and "WARNING" followed by important product information. So that you may better understand the manual, those terms are as follows:

NOTE: Includes additional information to enable accurate and easy performance of procedure.

IMPORTANT: Includes additional information that if not followed could lead to hindered product performance.

CAUTION

Used without the safety alert symbol, indicates a potentially hazardous situation which, if not avoided, may result in property damage.

⚠ CAUTION

Indicates a potentially hazardous situation which, if not avoided, may result in minor or moderate injury.

⚠ WARNING

Indicates a potentially hazardous situation which, if not avoided, could result in death or serious injury.

Fifth Wheel Design and Intended Use:

1. For pulling trailers with standard SAE kingpins which are in good condition and securely mounted or locked in position in the trailer.
2. Within the capacities stated in SAF-HOLLAND literature.
3. As recommended in SAF-HOLLAND literature (available from www.safholland.us).

Holland Fifth Wheels are NOT Designed or Intended For:

1. Use with non-SAE kingpins, such as kingpins which are bent, improper size or dimensions, not secured to maintain SAE configuration, or which are installed in warped trailer bolster plates.
2. Tow-away operations which damage or interfere with the proper operation of the fifth wheel.
3. The attachment of lifting devices.
4. The transport of loads in excess of rated capacity.
5. Applications other than recommended.

This manual contains the installation procedures for SAF-HOLLAND rebuild kit RK-03185-Series. Before rebuilding, verify that you have the correct rebuild kit for the fifth wheel top plate you are attempting to rebuild. The fifth wheel part number tag is located on the front of the fifth wheel (see **FIGURE 1**).

FIGURE 1

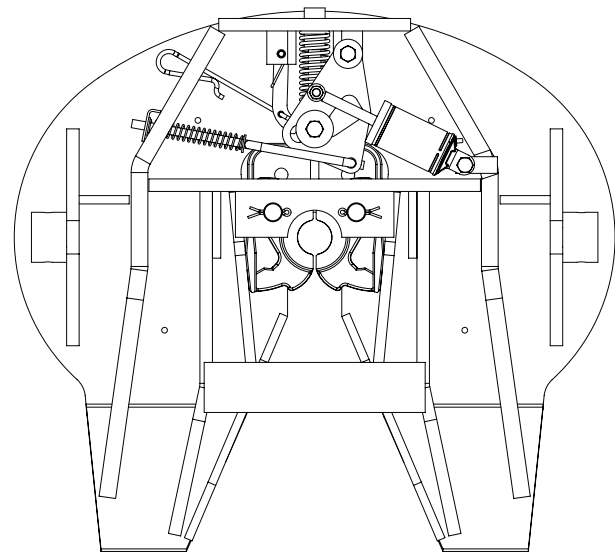
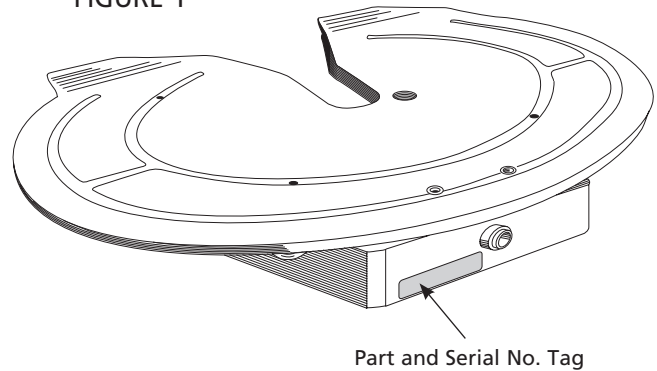

Use the proper RK-03185-Series rebuild kit to rebuild the following fifth wheel part numbers

ASSEMBLY	TOP PLATE	KIT PART NO.
FW2870-03184	XA-2801-03185-1	RK-03185-1
FW2870-03184-2	XA-2801-03185-2	RK-03185-1
FW2870-03184-3	XA-2801-03185-3	RK-03185-4
FW2870-03184-4	XA-2801-03185-4	RK-03185-4

XA-2801-03185 SERIES PARTS BREAKDOWN

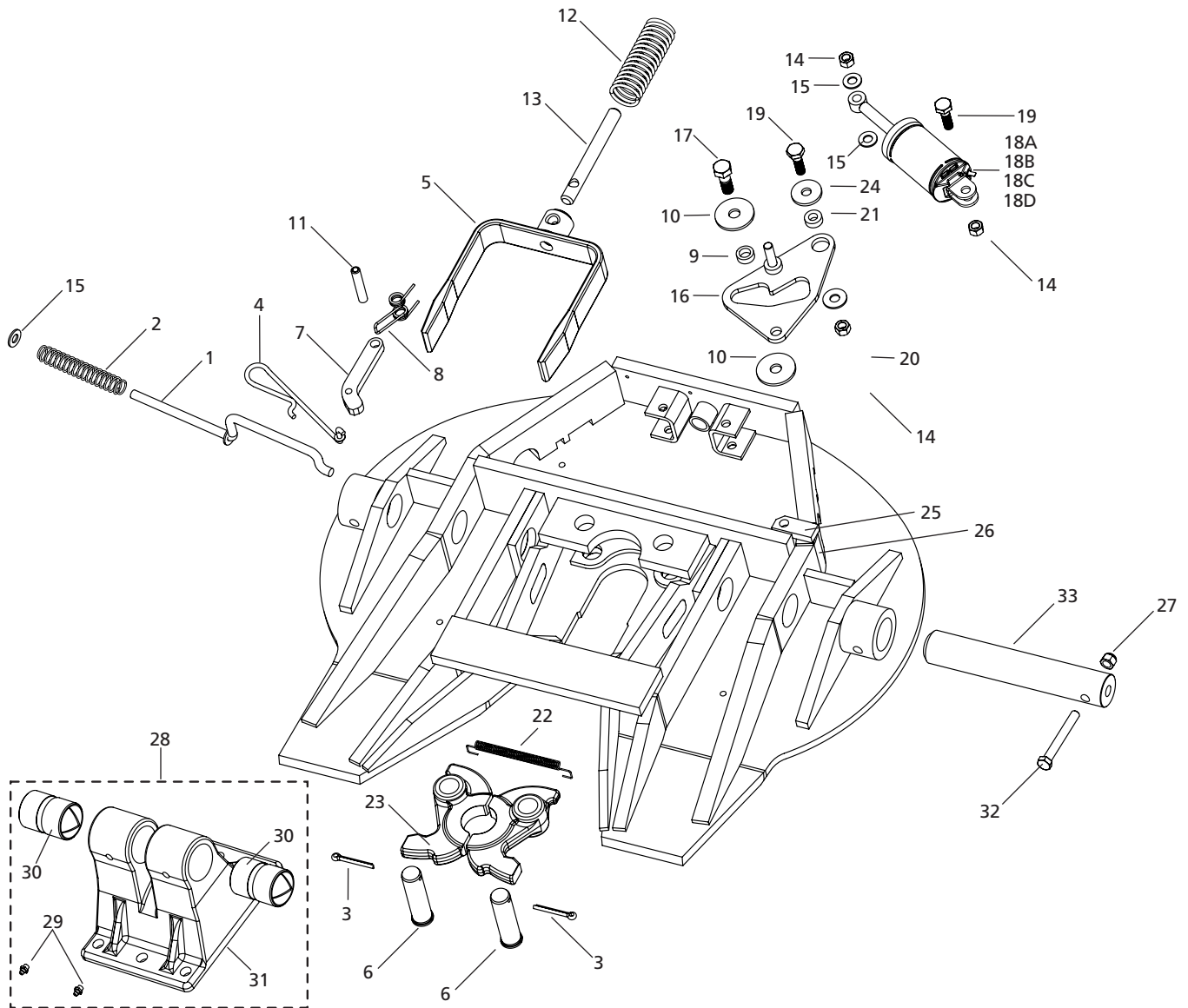

ITEM NO.	PART NO.	NO. REQ'D.	PART NAME	ITEM NO.	PART NO.	NO. REQ'D.	PART NAME
1	XA-1707-16	1	Handle S/A Release	18B	XA-2524-03185-4	1	Air Cyl. S/A for XA-2801-03185-3
2	XB-1028-1	1	Spring	18C	XA-2524-03185-1	1	Air Cyl. S/A for XA-2801-03185-2
3	XB-5	2	Cotter Pin, 1/4" x 2"	18D	XA-2524-03185-1	1	Air Cyl. S/A for XA-2801-03185-1
4	XA-3544-1-A	1	Handle S/A	19	XB-2083	2	HHCS, 1/2"-20 x 13/4"
5	XA-1703-F	1	Yoke	20	XB-T-49	1	Washer, 1/2"
6	XA-1313	2	Lock Pin	21	XA-1029	1	Roller
7	XA-3528	1	Lock Bar	22	XB-GT-13-1	1	Extension Spring
8	XB-2149	1	Torsion Spring	23	XA-1704-X	1	Lock Set
9	XA-1507-1	1	Cam Roller	24	XB-10267	1	Washer, 9/16"
10	XB-1030-1	2	Washer	25	XA-2836	1	Cylinder Support
11	XB-21-S-500-2750	1	Roll Pin	26	XA-2836-1	1	Spacer
12	XB-1505	1	Spring	27*	XB-0103	2	Lock Nut, 1/2"-13
13	XA-1706-1	1	Yoke Shaft	28*	XA-03189-1	2	Bracket S/A
14	XB-T-69-A	3	Lock Nut, 1/2"-20	29*	XB-H-38	4	Lub Fitting
15	XB-PW-1732-1-116	3	Washer, 1/2"	30*	XA-0861	4	Bearing
16	XA-1705-11	1	Cam Plate S/A	31*	XA-03193-1	2	Bracket S/A
17	XB-CX-58-F-134	1	HHCS, 5/8"-18 x 13/4"	32*	XB-BR-12-C-4	2	HHCS, 1/2"-13 x 4"
18A	XA-2524-03185-4	1	Air Cyl. S/A for XA-2801-03185-4	33*	XA-2809	2	Pivot Shaft

* Not included in rebuild kit.

REBUILD PROCEDURE

Disassembly and Inspection

1. Remove the fifth wheel top plate from the tractor.
2. Place fifth wheel top plate upside down on a flat working surface.
3. Completely disassemble the fifth wheel top plate.

IMPORTANT: This rebuild procedure will result in several parts of your fifth wheel being replaced. "NEW" parts are included in the rebuild kit that came with this procedure. Do not reuse "OLD" parts that were removed during disassembly.

4. Thoroughly steam clean the top plate.
5. Inspect the top plate for cracks, damage, distortion and loose lock pin holes.
Fifth wheels with cracks or loose lock pin holes must be replaced.

IMPORTANT: Do not attempt to repair or rebuild the fifth wheel if the top plate is cracked, damaged or distorted, or if the lock pins do not fit tightly in the top plate.

WARNING Failure to replace a cracked, damaged or distorted top plate could result in improper fifth wheel operation and trailer separation which, if not avoided, could result in serious injury or death.

Welding

1. Weld **ITEM 26** (XA-2836-1) as shown in **FIGURE 2** using 1/4" fillet welds.
2. Weld **ITEM 25** (XA-2836) onto **ITEM 26** (XA-2836-1) shown in **FIGURE 2** using 1/4" fillet welds.

IMPORTANT: When welding use a procedure which ensures a sound, good quality weld and which protects the operator and others. Overwelding may cause distortion and damage; underwelding may not develop sufficient strength. A low hydrogen process and an AWS E70XX filler metal are recommended. Take precautions to ensure that the tractor electrical system is not damaged by the welding.

WARNING Failure to properly weld air-cylinder mounts could allow parts to separate from the fifth wheel which, if not avoided, could result in serious injury or death.

FIGURE 2

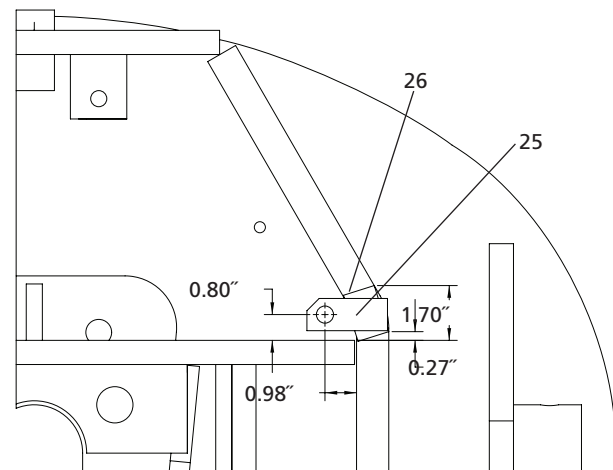

BOTTOM VIEW

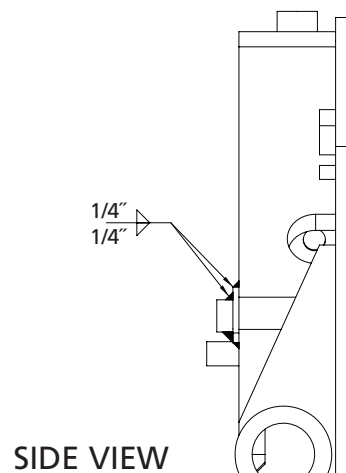

SIDE VIEW

REBUILD PROCEDURE

Lock Installation

1. Lubricate the lock pin holes of the lock jaws (**ITEM 23**) with Never-Seez (provided in kit). **DO NOT SUBSTITUTE.**

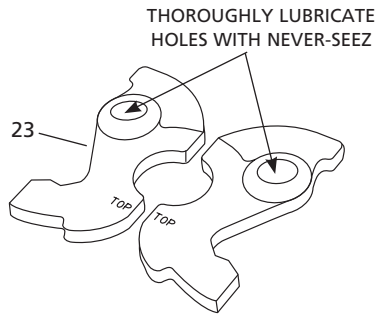

2. Align the lock jaws (**ITEM 23**) in the top plate, as shown.

With fifth wheel upside down, flip the lock jaws over so that the words 'TOP' are facing the underside of the top plate and are not visible on the locks as they are installed.

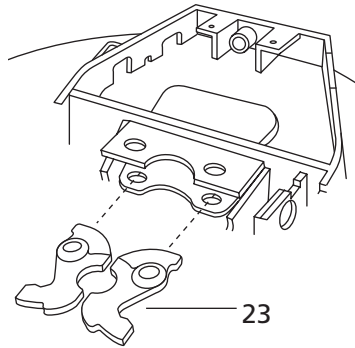

3. Align the holes in the lock pins (**ITEM 6**) so that cotter pins can be inserted, as shown.

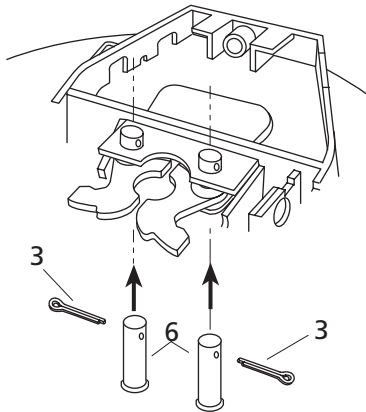

4. Drive pins into casting until heads are flush with the top plate.

5. Insert cotter pins (**ITEM 3**) and spread.

⚠ WARNING Failure to use tight fitting lock pins in a properly functioning top plate may cause the locks to malfunction, causing a loss of vehicle control which, if not avoided, could result in death or serious injury.

NOTE: If lock pins are not tight, contact SAF-HOLLAND Customer Service.

Yoke Installation

1. Lubricate the tips of the yoke with a light grease, as shown.

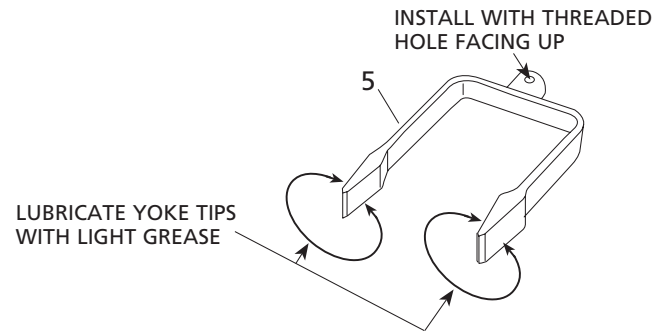

2. With the threaded hole facing up, slide yoke (**ITEM 5**) into top plate. Tap lightly to seat yoke around locks.

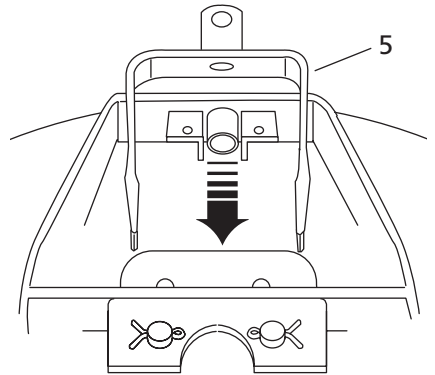

3. Install lock spring (**ITEM 22**), as shown.

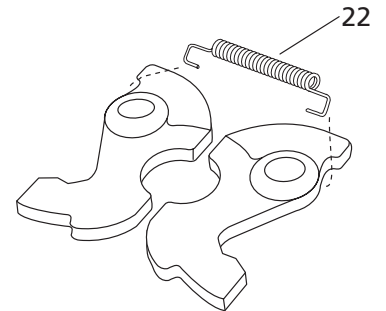

4. Install yoke spring (**ITEM 12**), as shown in Step 5.

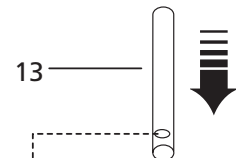

5. Next, slide the yoke shaft (**ITEM 13**) into the top plate, through the spring and into the yoke. Align the recessed hole in the shaft with the threaded hole in the yoke.

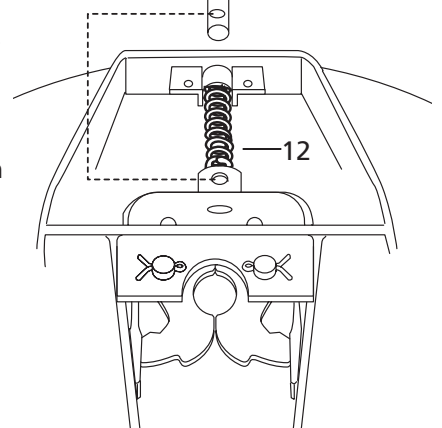

REBUILD PROCEDURE

Cam Plate Installation

1. In this order, slide the handle spring (**ITEM 2**) and a 1-1/16" O.D. washer (**ITEM 15**) onto the release handle (**ITEM 1**), as shown below.
2. Next, slide the straight end of the release handle rod (**ITEM 1**) through the inside rib of the top plate into opening "B", as shown below.

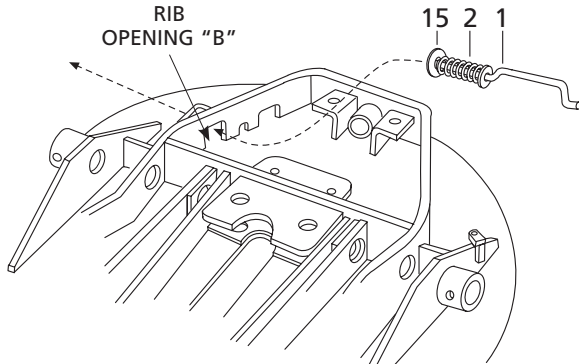

3. Insert the "S" bend of the release handle (**ITEM 1**) rod into the hole in the cam plate (**ITEM 16**), as shown below.

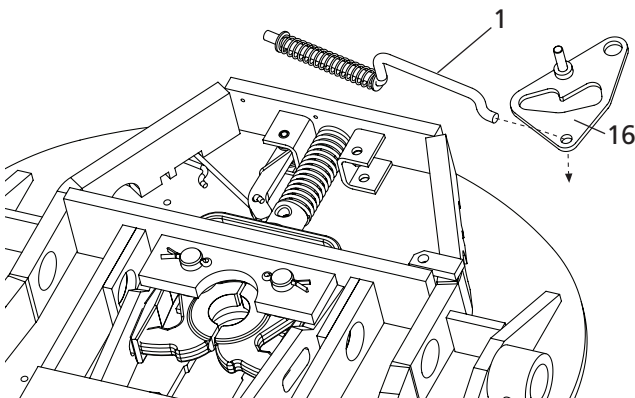

4. Position the cam plate pivot hole over the top plate lug as shown. Slide a 1-3/8" O.D. washer (**ITEM 20**) between the cam plate (**ITEM 16**) and the top plate lug with the rounded side of the washer facing the cam plate.

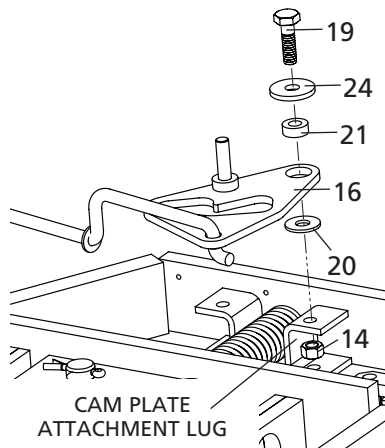

5. NOTE: When installing washers (**ITEMS 10, 20, and 24**), the rounded edge of the washers must always face the cam plate.

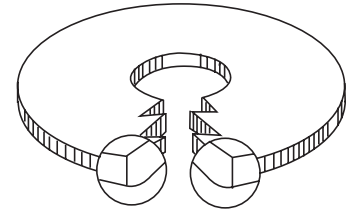

6. Install the 1/2" I.D. roller (**ITEM 21**) into the cam plate and place a 2-1/2" O.D. washer (**ITEM 24**) on top of the roller with the rounded side facing the cam plate.
7. Install the 1/2" bolt (**ITEM 19**) through the washers, roller and top plate lug.

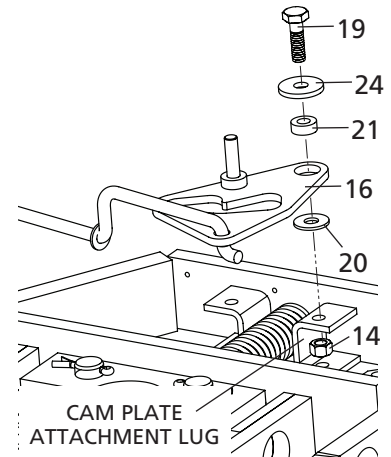

8. Secure the bolt with a 1/2" lock nut (**ITEM 14**). Tighten securely. Then check for free movement of the cam plate.
9. Next, align the cam plate track over the threaded hole in the yoke.

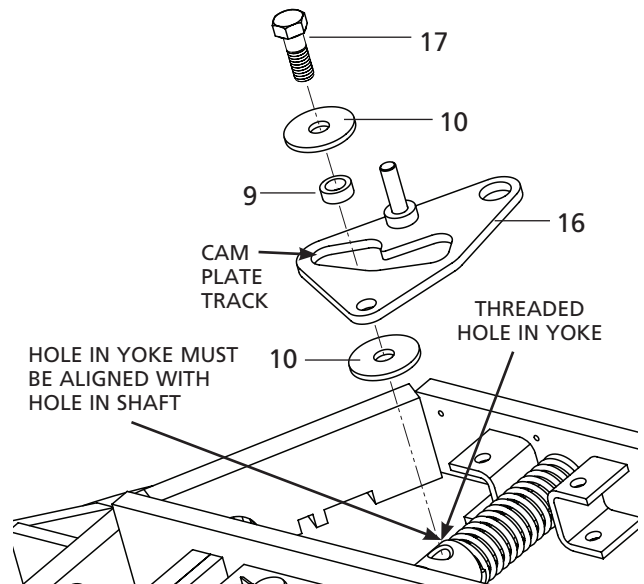

continued

REBUILD PROCEDURE

Cam Plate Installation *continued*

- Slide the 2 1/4" O.D. washer (**ITEM 10**) between the yoke and the cam plate.
- Place a 5/8" I.D. roller (**ITEM 9**) into the cam plate track, then place a 2 1/4" O.D. washer (**ITEM 10**) over the roller with the rounded side of the washer facing the cam plate.
- Check the alignment of the recessed hole in the yoke shaft. See below.
- Install the 5/8" bolt (**ITEM 17**) through the washers, roller and cam plate and into the threaded hole in the yoke.
Make sure that the bolt enters the recessed hole in the yoke shaft, as shown.
- Tighten the bolt securely, then check for free movement of the cam plate.

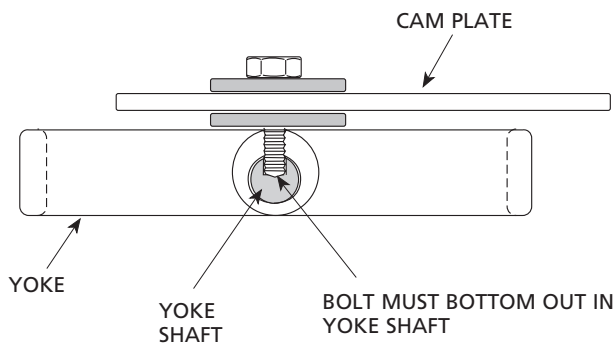

Secondary Lock Installation

- Pass the "S" bend of the manual secondary release handle (**ITEM 4**) through the rib guide hole, as shown below.

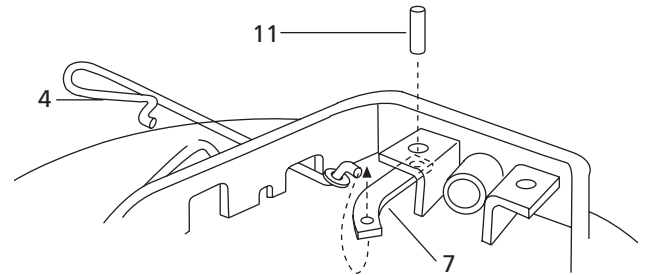

- Pass the "S" bend of the release handle through the large hole in the secondary lock (**ITEM 7**), as shown.
Start the roll pin (**ITEM 11**) into the hole in the top plate opposite the cam attachment bolt.
- Assemble the secondary lock (**ITEM 7**) to the torsion spring (**ITEM 8**), as shown.

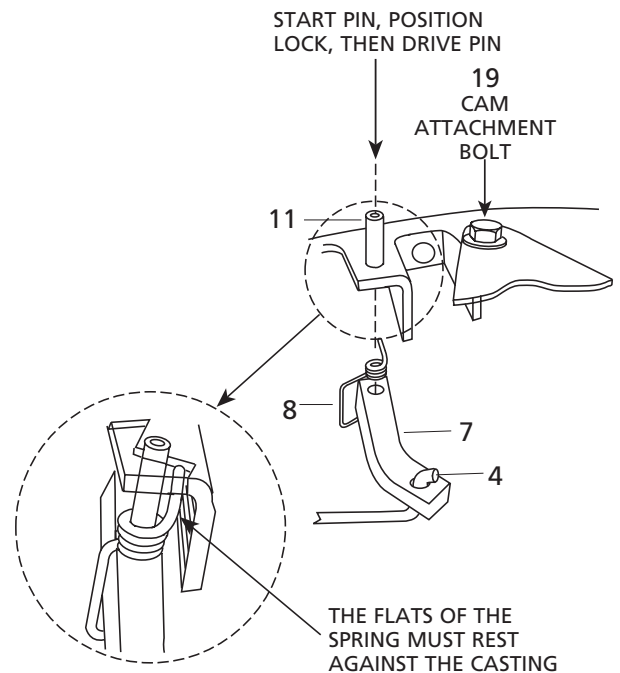

- Drive the roll pin (**ITEM 11**) through the spring and lock until flush with the tab.
Check the lock spring for tension and lock for free movement.

REBUILD PROCEDURE

Air Cylinder Installation

1. Position the air cylinder (**ITEM 18**) so that the open end of the inlet hole faces the tractor cab.
2. Position the round tab on the rod end of the air cylinder over the stud on the cam plate (see figure at right).
3. Position the clevis on the fixed end of the air cylinder over the mounting tab on the fifth wheel rib (see figure at right).
4. Secure the air cylinder using the bolt (**ITEM 19**) and nuts (**ITEM 14**), as shown.

NOTE: The hex-head, cap screw (**ITEM 19**) is inserted so that the head is accessible from the underside of the top plate.

NOTE: Before installing the FULLY assembled fifth wheel onto the brackets, check the operation of the air cylinder. Stand clear of the release handle! The handle will move out while performing the test.

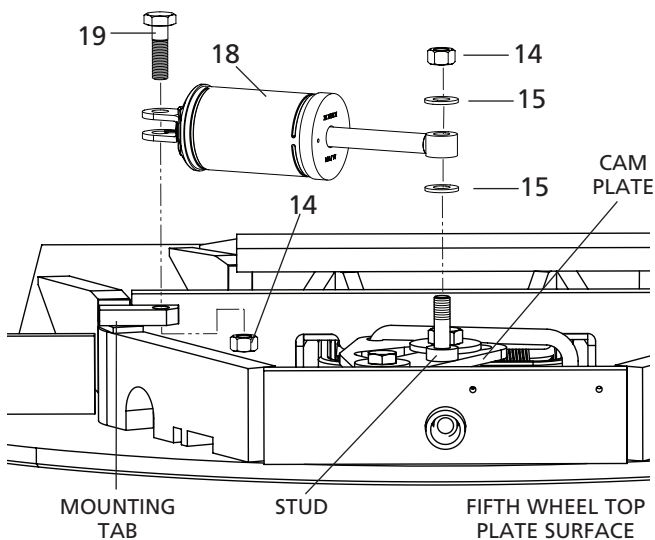

Operation Check

Before you use your fifth wheel, you must verify that it is operating properly.

1. Open and close the fifth wheel at least three (3) times using an SAF-HOLLAND Lock Tester.
2. Each time you close the locks, verify that the locks have closed completely around the kingpin.
3. After three (3) successful operational checks, your fifth wheel is ready for operation.

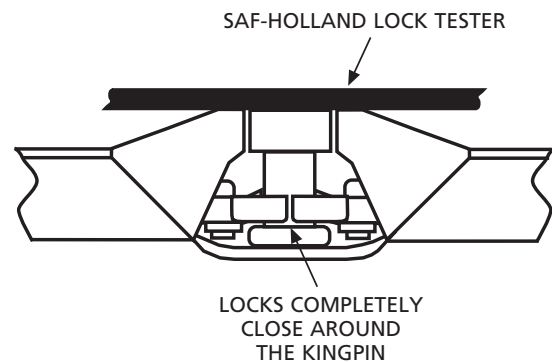

IMPORTANT: If the fifth wheel does not operate properly, **DO NOT USE IT!** Disassemble the fifth wheel and repeat the rebuild procedure or contact SAF-HOLLAND Customer Service at the telephone number listed below on this document. Never use a fifth wheel that does not operate properly.

WARNING Failure to properly install a fifth wheel top plate may allow improper locking of the fifth wheel and potential trailer separation which, if not avoided, could result in serious injury or death.