



GO THE DISTANCE.

FIFTH WHEEL

INSTALLATION, OPERATION, and MAINTENANCE INSTRUCTIONS



Fifth Wheel Coupler with Retracting Kingpin

FW0001 Series Fifth Wheel
FW0002 Series Fifth Wheel
FW0005 Series Fifth Wheel
KP0030 Kingpin Assembly

32,000 lbs. Maximum Gross
Trailer Weight

8,000 lbs. Maximum Vertical Load

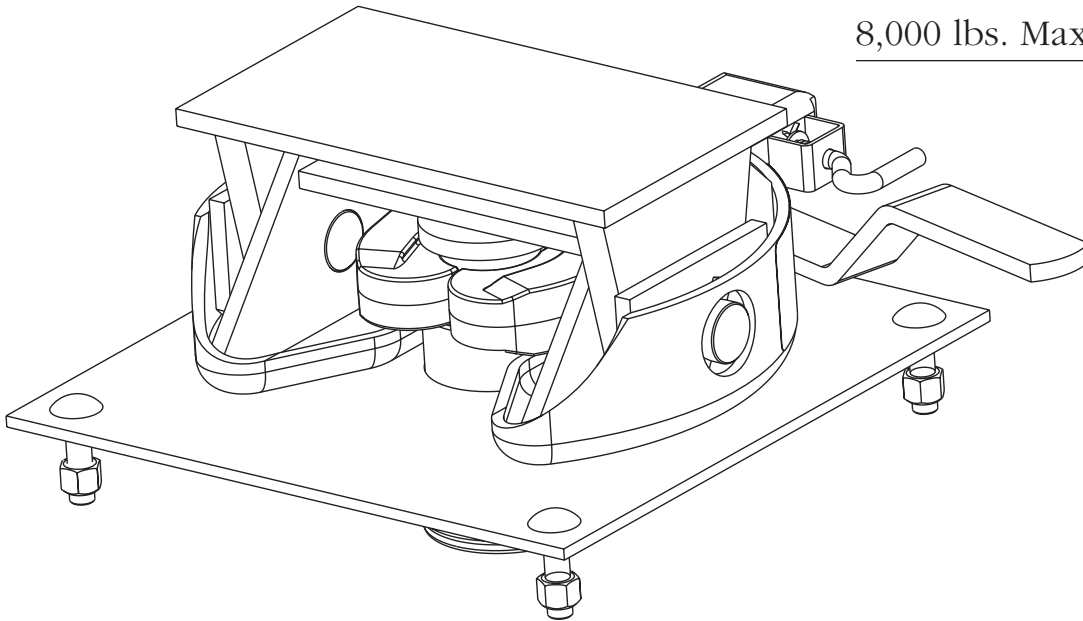

U.S. Patent 3,870,342
Foreign Patents 1,008,897 & 485,706

FW0001 and FW0002 SERIES FIFTH WHEEL PARTS BREAKDOWN

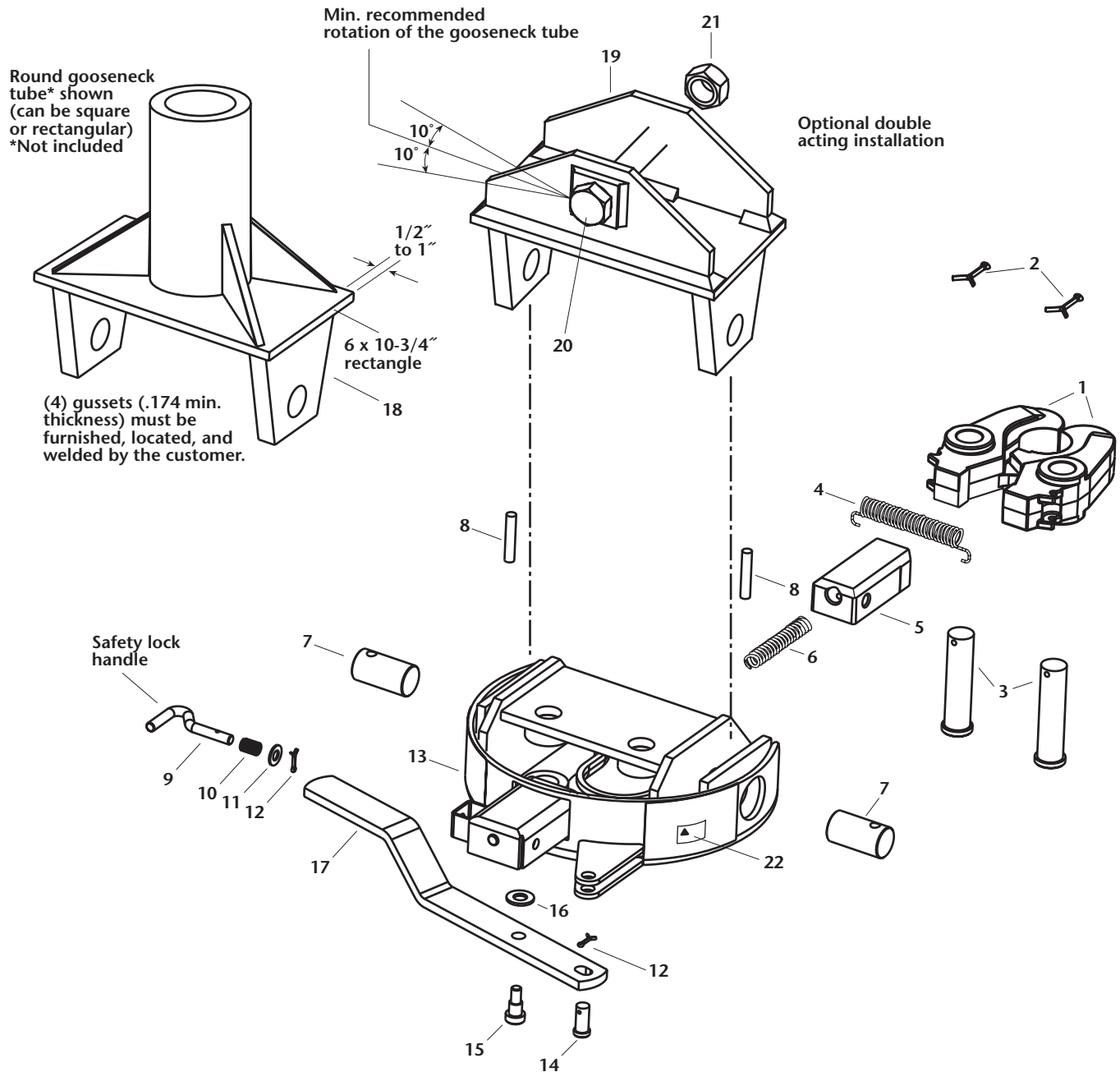

ITEM NO.	PART NO.	QTY.	DESCRIPTION
1	XB-BFW0172	1	Jaw coupling
2	XB-CTP-014-59	2	Cotter pin, $\frac{3}{16}$ " dia. x $1\frac{1}{2}$ "
3	XB-CLP-052-25	2	Clevis pin, 1" dia. x 4"
4	XB-SPG-020-21	1	Extension spring
5	XB-BFW0170-01	1	Locking block
6	XB-SPG-020-08	1	Compression spring
7	BFW0173	2	Clevis pin, $1\frac{1}{4}$ " dia.
8	XB-GP-052-21	2	Groove pin $\frac{3}{8}$ " dia. x 2"
9	XB-BFW0118	1	Safety lock handle
10	XB-SPG-020-06	1	Compression spring
11	XB-PW-016-03	1	Flat washer
12	XB-CTP-014-51	2	Cotter pin, $\frac{1}{8}$ " dia. x $\frac{3}{4}$ "
13	BFW0100	1	Fifth wheel housing S/A

ITEM NO.	PART NO.	QTY.	DESCRIPTION
14	XB-CLP-052-26	1	Clevis pin, $\frac{1}{2}$ " dia. x $1\frac{1}{16}$ "
15	XB-SHS-007-02	1	Shoulder screw, $\frac{1}{2}$ " dia. x $\frac{1}{2}$ "
16	XB-PW-016-17	1	Flat washer, $1\frac{1}{16}$ " O.D.
17	BFW0122	1	Trip lever
18	BFW0101	1	Attaching plate S/A
19	BFW0104-35	1	Swivel attaching plate S/A, $3\frac{1}{2}$ "
	BFW0104-40	1	Swivel attaching plate S/A, 4"
	BFW0104-45	1	Swivel attaching plate S/A, $4\frac{1}{2}$ "
20	XB-SP0050-73	1	Hex hd. bolt, 1-14 x 6 (BFW0104-35)
	XB-SP0050-97	1	Hex hd. bolt, 1-14 x $6\frac{1}{2}$ (BFW0104-40)
	XB-HHC-050-52	1	Hex hd. bolt, 1-14 x 7 (BFW0104-45)
21	XB-SLN-012-46	1	Hex, self-locking nut, 1-14
22	XB-BFW0175	1	Warning decal

MAINTENANCE AND LUBRICATION INSTRUCTIONS

1. The kingpin should be raised with a threaded handle (Item no. 31 below). Wipe the kingpin and 14" x 14" plate to remove all dirt. Then, wipe or spray a dry film lubricant on these surfaces. (For the best results and minimum wear, this should be done on a timely basis to prevent surfaces from being totally dry.)
2. The fifth wheel normally requires no lubrication if it is kept clean and free of excess dirt, rust, ice, etc.

If the mechanical action becomes sluggish, clean all dirt, rust, and ice from the fifth wheel and spray all of the moving parts, surfaces, and joints with a dry film lubricant.

KP-0030 KINGPIN PARTS BREAKDOWN

ITEM NO.	PART NO.	QTY.	DESCRIPTION
23	BFW0230	1	Mounting plate S/A
24	BFW0225	1	Machined kingpin
25	BFW0229	1	Plunger
26	XB-SPG-020-09	1	Compression spring
27	XB-CTR-014-61	1	Cotter pin, 1/4" dia. x 2"
28	XB-MS-C-038-05	1	Plastic plug
29	XB-SLN-012-07	4	Hex hd. lock nut, 1/2-13
30	XB-SNB-004-02	4	Carriage bolt, 1/2-13 x 2
31	XB-BFW0208	1	Handle

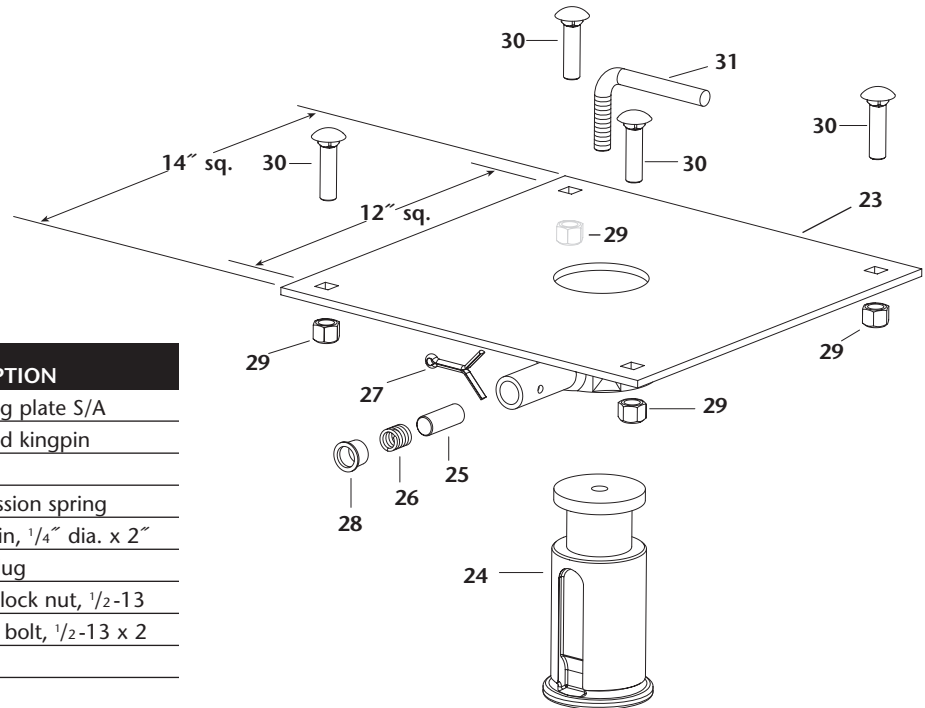

CONNECTING THE FIFTH WHEEL TO THE KINGPIN

1. Lower the tail gate (if a pick up truck).
2. Raise the kingpin.
3. Pull out the safety lock handle (*Item 9*) until the trip lever (*Item 17*) moves inward pushing the locking block (*Item 5*) against the back side of the coupling jaws (*Item 1*). **The coupling jaws remain open to allow the entrance of the kingpin.**
4. Crank the trailer support jack until the fifth wheel is higher than the truck bed.
5. Slowly back the truck toward the fifth wheel until within approximately 1 ft. of the kingpin.
6. Lower the trailer until the fifth wheel lightly touches the truck bed.
7. Continue backing the truck up until the fifth wheel is automatically locked. **Make certain that the fifth wheel is locked with a safety lock handle (*Item 9*) behind the locking block (*Item 5*).**

UNCOUPLING PROCEDURE

1. Position the truck and trailer on firm, level ground clear of obstacles and people.
2. Set trailer brakes and chock trailer wheels.
3. Lower the landing gear; when the foot pad contacts the ground, crank two or three additional turns to reduce the vertical load on the fifth wheel. Do not raise the fifth wheel off the kingpin plate.
4. If the truck/tractor is equipped with a body, lower the tailgate.
5. Disconnect the power/brake line and, if the trailer is equipped with electric brakes, unhook the break-away switch line. Do not disconnect at the switch.
6. Open the fifth wheel locks by pulling out the safety lock handle (*Item 9*) and pulling open the trip lever (*Item 17*) until the safety lock handle locks onto the locking block (*Item 5*).
7. Drive away from the trailer slowly.
8. Raise the tailgate if so equipped.

KINGPIN INSTALLATION

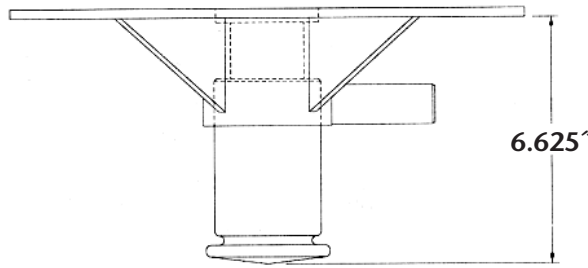

6.625" **Allowable clearance for the kingpin storage position.**

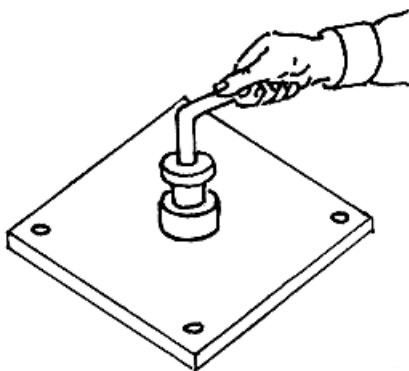
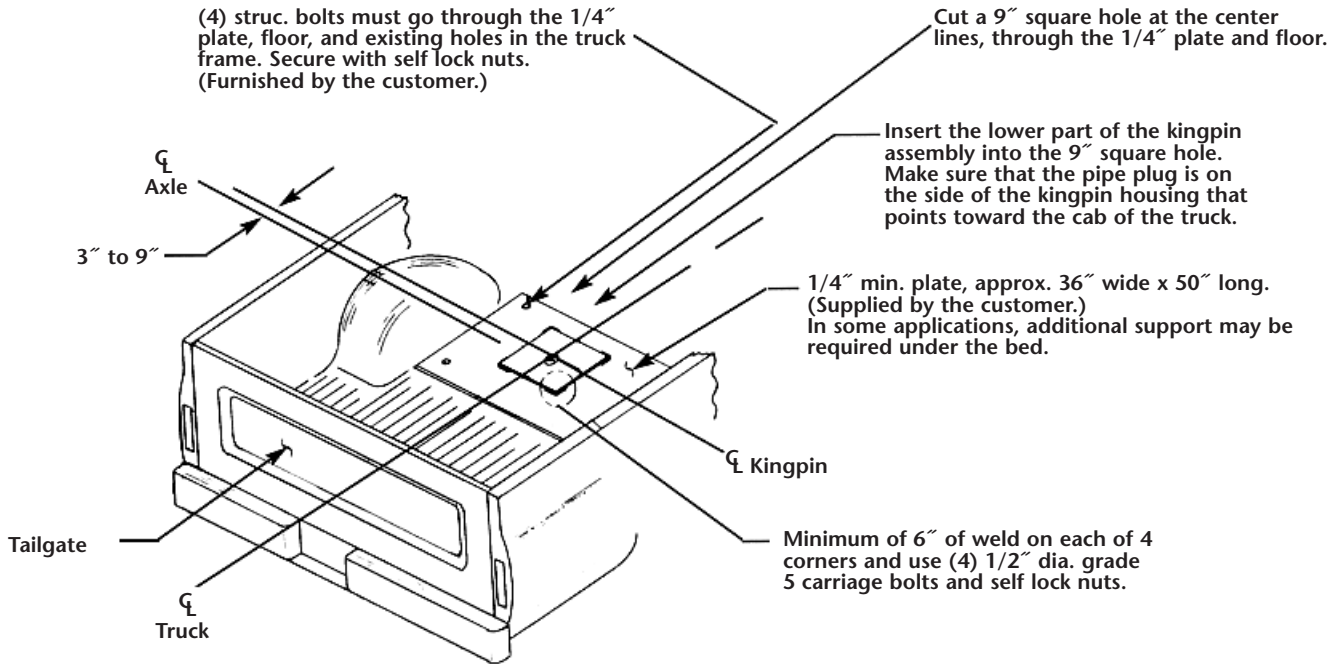

TO RAISE

Lift with a threaded handle
(item no. 31 on pg 3)

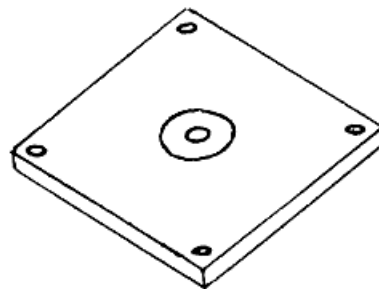

TO RETRACT

Step on the kingpin with your foot. Do not use hands.

Copyright © July 2003 • The Holland Group, Inc.

Holland USA, Inc. Facilities:

Dumas, AR Warrenton, MO
Holland, MI Wylie, TX
Muskegon, MI

Ph: 888-396-6501 Fax: 800-356-3929

Holland International, Inc.

Holland, MI
Phone: 616-396-6501
Fax: 616-396-1511

Holland Hitch of Canada, Ltd.

Woodstock, Ontario • Canada
Phone: 519-537-3494
Fax: 800-565-7753

Holland Equipment, Ltd.

Norwich, Ontario • Canada
Phone: 519-863-3414
Fax: 519-863-2398

Holland Hitch Western, Ltd.

Surrey, British Columbia • Canada
Phone: 604-574-7491
Fax: 604-574-0244