



FIFTH WHEELS

FWS1/FWS2 AIR CYLINDER REPLACEMENT KIT

RK-10999 Replacement Kit

Air Cylinder Replacement Procedures for Holland FWS1/FWS2 Fifth Wheels

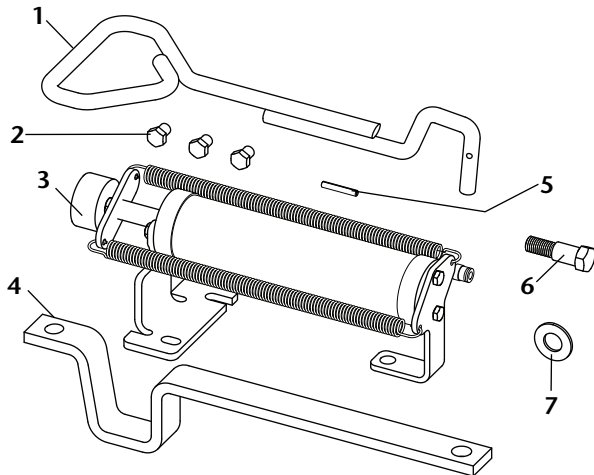

IMPORTANT SAFETY INFORMATION

1. All fifth wheel maintenance must be performed by a qualified service technician using proper tools and safe procedures.
2. Use only SAF-HOLLAND Original Parts.
3. Wear safety goggles during disassembly and assembly of the fifth wheel.
4. Keep fingers away from all potential pinch points in the fifth wheel.
5. Do not weld on this product. Do not deviate from the instructions contained in this manual. Any changes or deviations from these procedures will void all warranties, express or implied, unless prior written consent is obtained from SAF-HOLLAND.
6. Always verify proper operation and adjust the fifth wheel following the procedures contained in this manual before placing back in use.

RK-10999 FWS1/FWS2 Air Cylinder Replacement Kit

ITEM	DESCRIPTION	PART NO.	QTY.
1	Handle Air Release	XA-11112	1
2	Bolts, 3/8"-16 x 1/2"	XB-11027	3
3	Air Cylinder Touchloc	XA-10999	1
4	Lever Bar, FWS1/FWS2 Air Release	XA-11113	1
5	Spring Pin	9900181	1
6	Shoulder Bolt	XB-11127	1
7	Washer	XB-T-199	1

IMPORTANT: Verify that the contents of this package are complete. If you are missing any items, please contact your dealer or distributor.

⚠ WARNING All of the required parts in this kit **MUST** be used. **DO NOT** substitute other or used parts. Improper part combinations can cause the product to couple improperly which, if not avoided, could result in death or serious injury.

IMPORTANT: **DO NOT** attempt repairing or rebuilding if the top plate is cracked or distorted or if the lock pins do not fit tightly in the top plate as the top plate may fail or the locks may malfunction.

⚠ WARNING Failure to replace a malfunctioning top plate may cause loss of vehicle control which, if not avoided, could result in death or serious injury.

AIR CYLINDER KIT REPLACEMENT PROCEDURE

Disassembly

NOTE: Air cylinder removal and replacement DOES require removal of the fifth wheel from tractor.

1. Close the jaw and lock mechanism using a bar or lock tester (*Figure 1*).

Figure 1

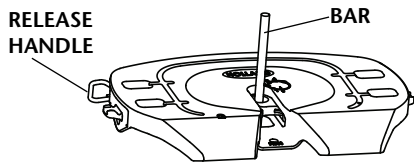

IMPORTANT: Use a bar or block to rotate jaw when opening or closing the locking mechanism. When locking the jaw, stand clear of the release handle as it retracts rapidly during lockup.

CAUTION Lock is spring-loaded. Prevent injury by keeping hands away from jaw and lock which, if not avoided, could result in serious injury to hands or fingers.

- 2a. Turn off air supply to the fifth wheel assembly.

- 2b. Push the end of the “quick release” swivel fitting inward while gently pulling the air line out of the fitting as shown in *Figure 2*.

Figure 2

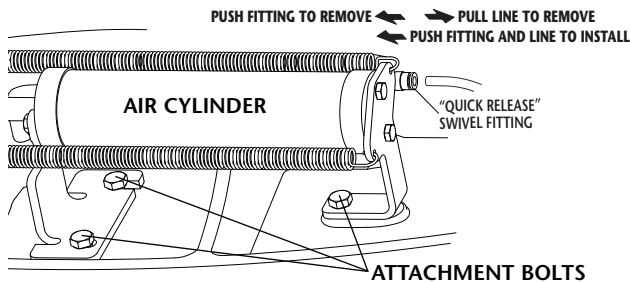

3. Remove the bracket pin retention bolts and nuts from the top plate, then, using a pry bar, pull the bracket pins out of the fifth wheel top plate as shown in (*Figure 3*).

Figure 3

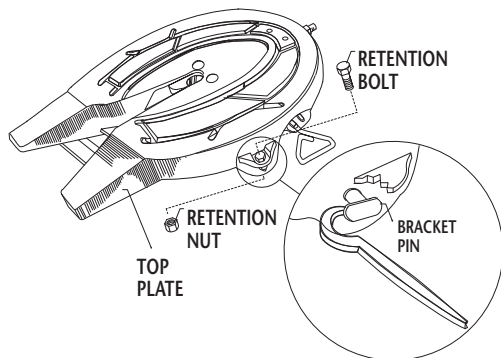

Disassembly *continued*

4. Using a proper lifting device, remove the top plate from the brackets and set aside.
5. Remove and discard three air cylinder attachment bolts (*Figure 2*).
6. Use a hammer to remove the release handle's spring pin under the top plate (*Figure 4*).

Figure 4

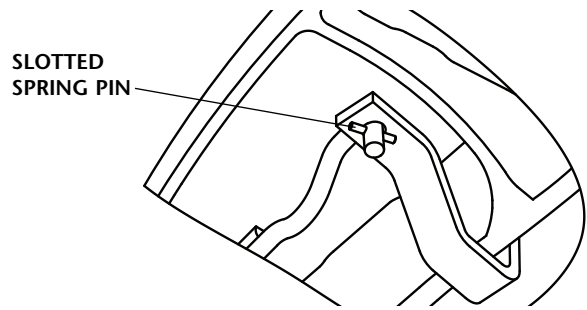

7. Remove shoulder bolt and washer (*Figure 5*).

Figure 5

HEX-HEAD SHOULDER BOLT CONNECTION

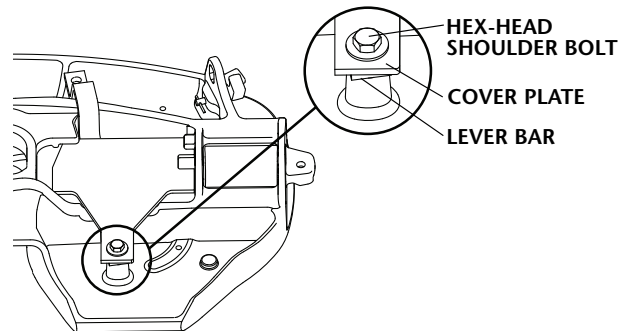

CAUTION Remove the cover plate slowly. Lock is spring-loaded. Prevent injury by keeping hands away from jaw and lock which, if not avoided, could result in serious injury to hands or fingers.

8. Slide the cover plate back until it clears both tabs (Arrow **A**), lift and remove (*Figure 6*).

Figure 6

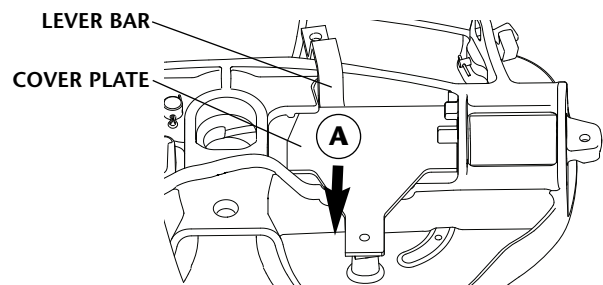

continued

Disassembly *continued*

- Separate the release handle from the lever bar (*Figure 7*) and remove release handle from fifth wheel.

Figure 7

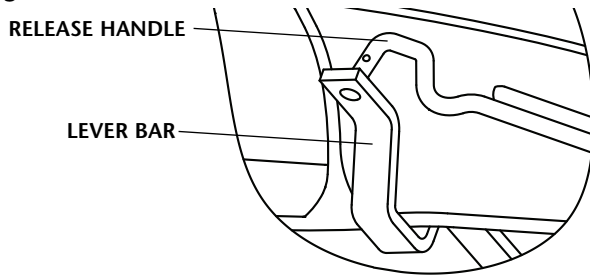

- Remove lever bar.

- Discard used parts.

Reassembly

NOTE: Using new kit parts, reassemble fifth wheel in the following sequence.

- Place lever bar as shown in (*Figure 9*).
- Install new release handle into fifth wheel and through lever bar (*Figure 8*).

Figure 8

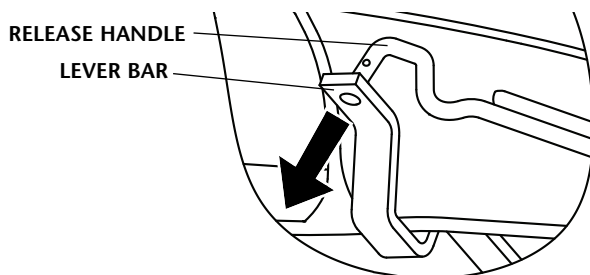

- Install cover plate and ensure it is engaged under tabs in fifth wheel (*Figure 9*).

Figure 9

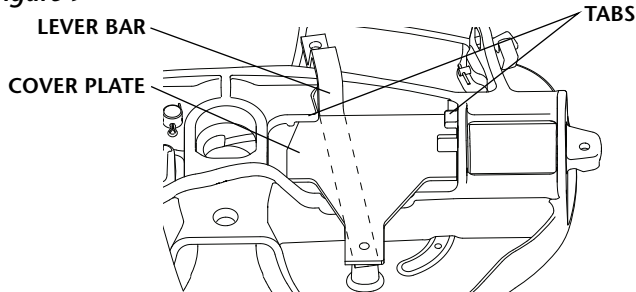

- Using new shoulder bolt and new washer, install shoulder bolt and washer through cover plate and new lever bar (*Figure 10*).

NOTE: Tighten shoulder bolt to 80 ft-lbs.

Reassembly *continued*

Figure 10

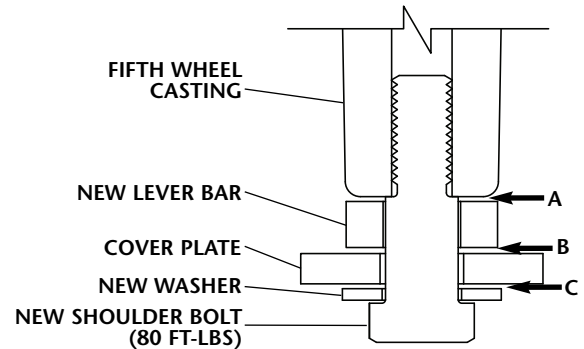

**NORMAL SPACING (A, B & C) AFTER BOLT INSTALLATION.
FREE PLAY IS THE ALLOWED VERTICAL MOVEMENT (3/16" TOTAL) IN WASHER/COVER PLATE/LEVER BAR STACK.**

- Use a hammer to insert spring pin into hole on end of release handle (*Figure 11*).

Figure 11

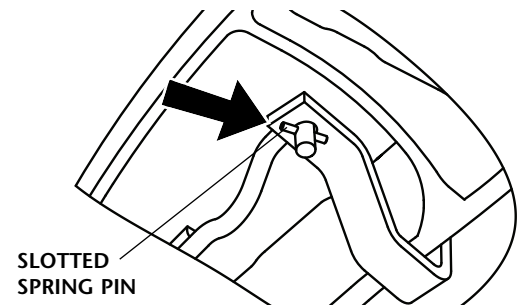

- Position new air cylinder over the three mounting holes. Using 3 new bolts, carefully thread each one into fifth wheel (*Figure 2*).

NOTE: Before bolts are tight, ensure that the plunger nose of the air cylinder is roughly centered on the end of the release handle. Tighten bolts securely.

- Using a proper lifting device, set the top plate on the brackets.
- On the back side of the air cylinder, push the end of the "quick release" swivel fitting inward while gently pushing the air line into the fitting as shown in *Figure 2*.
- Insert the bracket pins and re-attach the bracket pin retention bolts and nuts—and securely tighten (*Figure 3*).

continued

Fifth Wheel Adjustments

To ensure that the fifth wheel locks properly, perform the Coupling Procedures in the “FWS1/FWS2 Series Owner’s Manual” (XL-FW525).

If adjustments are necessary, perform the Required Inspections and Adjustments in the “FWS1/FWS2 Series Owner’s Manual” (XL-FW525).

⚠ WARNING Failure to properly operate this fifth wheel may cause tractor and trailer separation which, if not avoided, could result in death or serious injury.

If the fifth wheel does not operate properly, **DO NOT** use it! Contact SAF-HOLLAND Technical Customer Service for assistance.



SAF-HOLLAND USA, Inc.
888.396.6501 Fax 800.356.3929

SAF-HOLLAND Canada Limited
519.537.3494 Fax 800.565.7753
Western Canada
604.574.7491 Fax 604.574.0244