



KINGPIN

REMOVABLE KINGPIN SPECIFICATIONS



HOLLAND HITCH COMPANY REMOVABLE KINGPINS PROVIDE:

- Multiple kingpin settings to vary weight distribution and overall length.
- A tapered design for secure installation and quick removal to prevent kingpin damage (as may occur with folding goosenecks) and to ease kingpin replacement.

This series of kingpins is specifically designed for gooseneck, drop-frame and flatbed trailers but can be used for van and enclosed trailers if access is provided through the floor.

STANDARD FEATURES INCLUDE:

1. Kingpins of AISI 4140 steel, quenched and tempered for wear and strength.
2. Tapered engagement with the housing for firm, secure installation.
3. Locking dowel pin to prevent rotation – an aid in installation and removal.
4. Two models - one for standard 2" SAE kingpins and one which is convertible from 2" to 3.5".
5. Housings with protective plugs are sold separately and are available for multiple positions.
6. Bolster plate thicknesses are designed into the housings as shown below. Only one kingpin of the proper configuration is required if replacement is necessary.

DIMENSIONS

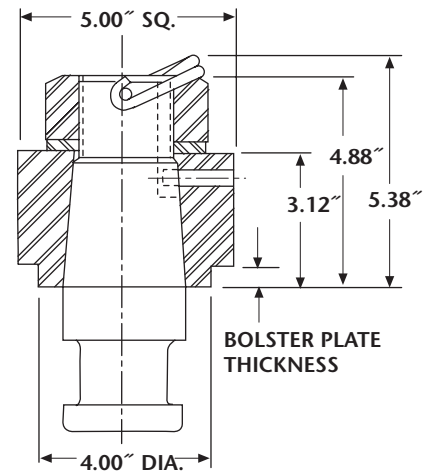

2" KINGPIN WITH HOUSING	HOUSING WITH PLUG	BOLSTER PLATE
KP-0427	KP-0438	0.25"
KP-0428	KP-0439	0.31"
KP-0412	KP-0440	0.38"
KP-0429	KP-0441	0.50"

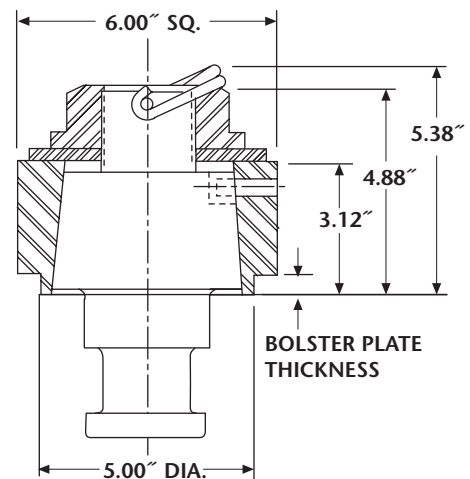

2" KINGPIN WITH HOUSING	3 1/2" KINGPIN WITH HOUSING	HOUSING WITH PLUG	BOLSTER PLATE
KP-0413	KP-0414	KP-0444	0.38"
KP-0432	KP-0433	KP-0445	0.50"

HOUSING INSTALLATION RECOMMENDATIONS:

1. The housing is designed for welded installation into the upper coupler assembly. The design of the upper coupler is the responsibility of the installer and must be consistent with the type and capacity of trailer and design loads for the upper coupler.
2. The housing is manufactured from AISI 1020 steel which is readily weldable; a low-hydrogen welding process is recommended. The "square" external shape of the housing will aid the attachment of required bracing or cross members.
3. Since the tapered hole in the housing is accurately machined, a welding procedure which alternates from side to side and which minimizes heat buildup is recommended to avoid distortion. The hole should also be protected from weld spatter during coupler construction.
4. An access opening must be provided through the trailer floor for field removal and installation of the kingpin.

KINGPIN INSTALLATION INSTRUCTIONS:



WARNING

The trailer must be securely chocked and supported to prevent the trailer from rolling or falling onto the installer.

1. Clean all foreign material from the housing and the kingpin. The application of a **VERY THIN** coating of rust preventative lubricant to the kingpin prior to installation will aid subsequent removal.
2. Insert the kingpin into the housing, aligning the dowel pin in the housing with the key slot on the kingpin. Hold in place while the washer and nut are installed by a helper from above.
3. Tighten the nut to a minimum of 300 foot pounds and install retaining pin through the castellations of the nut.

IMPORTANT

The kingpin must be checked periodically during use and retightened to proper torque if necessary.

4. Housing plugs are recommended to minimize corrosion and contamination when a kingpin is not installed in the housing. The plug is installed in a similar manner but is retained with a finger-tight thumb nut.

These products are covered by Holland's Commercial Products Warranty. Holland reserves the right, without giving prior notice, to change specifications and dimensions as designs are altered or improved.

PARTS BREAKDOWN

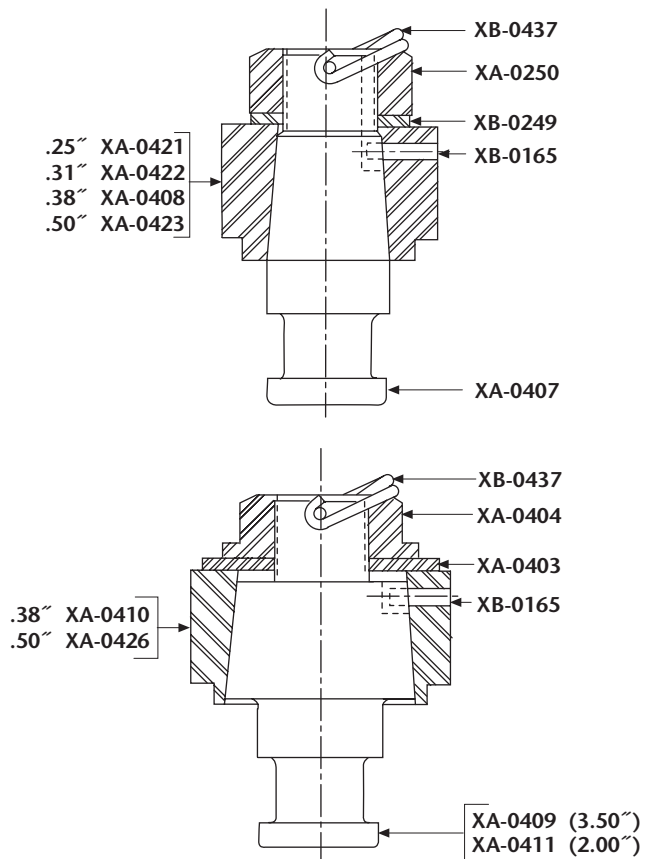

KINGPIN PLUGS

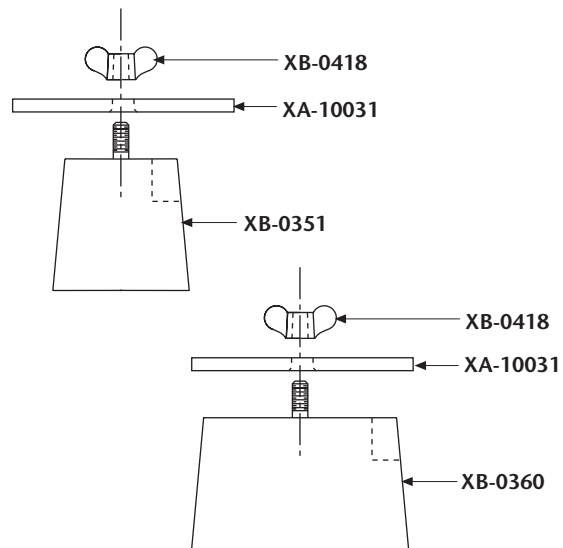

Copyright © September 2002 • The Holland Group, Inc.

Holland USA, Inc. Facilities:

Denmark, SC Warrenton, MO
Dumas, AR Whitehouse Station, NJ
Holland, MI Wylie, TX
Muskegon, MI

Ph: 888-396-6501 Fax: 800-356-3929

Holland International, Inc.

Holland, MI
Phone: 616-396-6501
Fax: 616-396-1511

Holland Hitch of Canada, Ltd.

Woodstock, Ontario • Canada
Phone: 519-537-3494
Fax: 800-565-7753

Holland Equipment, Ltd.

Norwich, Ontario • Canada
Phone: 519-863-3414
Fax: 519-863-2398

Holland Hitch Western, Ltd.

Surrey, British Columbia • Canada
Phone: 604-574-7491
Fax: 604-574-0244