

## Important Info – February 2018

### HOLLAND ATLAS Landing Gear

#### Product Change Notice for ATLAS Series Landing Gear Cross Drive Shaft Connection

SAF-HOLLAND® has made a product enhancement to the ATLAS Series landing gear cross drive shaft connection fastener

Effective February 14, 2018

#### Product Change:

Applicable to all ATLAS Series landing gear, which includes the following models: ATLAS 55/GD60, ATLAS 65/GD65, ATLAS iM and ATLAS 55 FG. This product will be enhanced with the replacement of the old style standard threaded cross drive shaft connection bolt with a new style long shank bolt. This connection bolt change will prevent the cross drive shaft connection from being over tightened which could lead to binding during cranking of the landing gear. The new style long shank bolt, when fully tightened with the lock nut to the proper torque spec (30 ft. lbs.), should allow the necessary side-to-side movement within the cross shaft slots on both ends.

This product enhancement will facilitate proper OEM installation and will not impact fit, form or function.

#### OLD STYLE

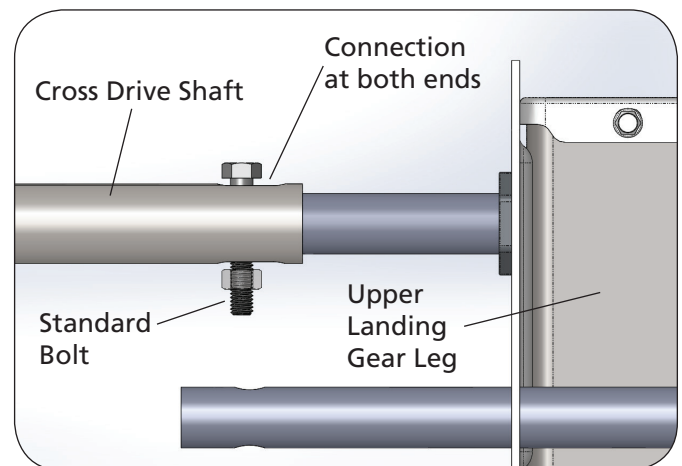

#### NEW STYLE

