



Important Info – November 2020

HOLLAND Mark V Landing Gear

Discontinuation of Cushion Foot on Mark V Landing Gear

Effective February 1, 2021

This product retirement notice applies all Standard Duty and Heavy Duty Mark V Landing Gear.

February 1, 2021, SAF-HOLLAND will Discontinue the cushion foot, option code 14 for all Standard Duty and Heavy Duty Mark V Landing Gear sold to OEM and Aftermarket customers.

Orders will be accepted until February 1, 2021. Service parts will be available through the SAF-HOLLAND Aftermarket for an extended period.

Customers seeking a cushion foot option for the Mark V should consider the Removable Cushion Foot (RCF), option code 24.

If you have any questions, or require additional product assistance, please contact your account manager or customer service representative.

Cushion Foot Discontinued for Mark V Landing Gear Effective February 1, 2021

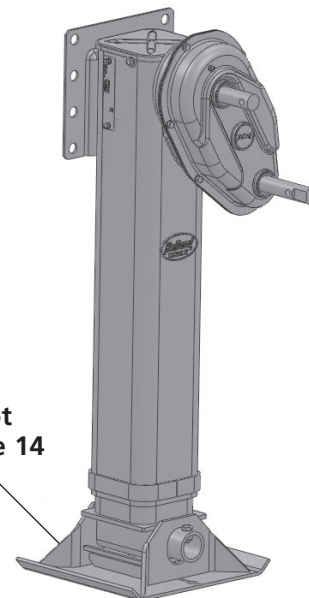

Cushion Foot
Option Code 14

Removable Cushion Foot (RCF) is Available for Replacement



Removable Cushion Foot
Option Code 24