

# INTERMODAL SOLUTIONS FOR TRACTORS AND TRAILERS

THE PERFECT PRODUCT SOLUTIONS FOR INTERMODAL TRACTOR AND CONTAINER CHASSIS TRAILERS



# PERFECT PRODUCT SOLUTIONS FOR INTERMODAL



TERMINAL TRACTOR  
FIFTH WHEELS AND  
MOUNTING SYSTEMS



WELD-ON AND  
REPLACEABLE  
KINGPINS



LANDING GEAR  
DESIGNED FOR  
INTERMODAL TRAILERS

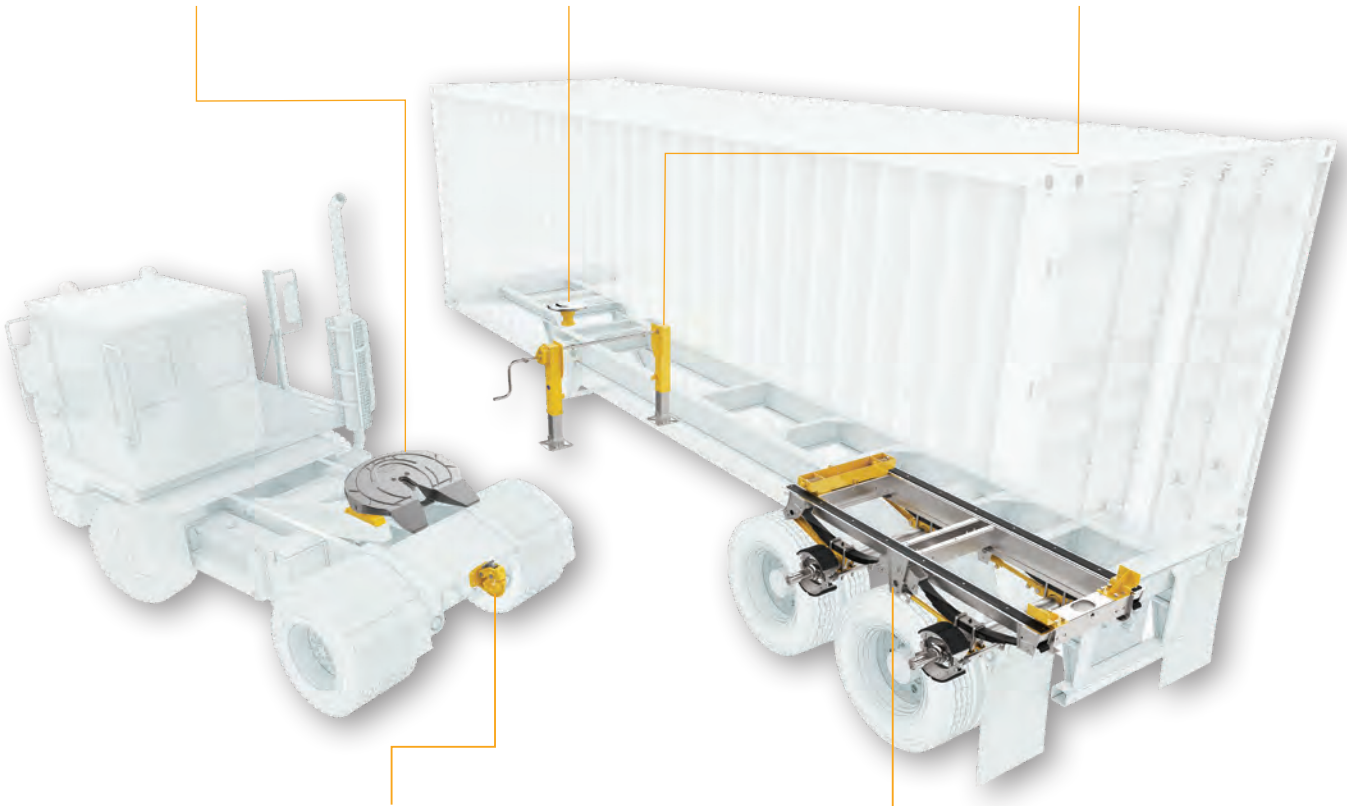

PINTLE HOOKS,  
DRAWBARS  
AND COUPLERS



MECHANICAL SLIDER AND  
FIXED FRAME SUSPENSION  
AXLE SYSTEMS



# THE STRONGEST, FASTEST AND MOST RELIABLE **TERMINAL TRACTOR** FIFTH WHEEL



The FW35TT is specifically designed for terminal tractor applications and built for long-life performance.

**FW35TT**  
**80,000 LBS. CAPACITY**  
 (36,287 kg) Maximum  
 Vertical Load



**1 PROVEN HOLLAND TWIN-LOCK™ DESIGN**

For the fastest and most reliable coupling design in the industry. Designed to prevent coupling delay or failure caused by kingpin bounce out.

**2 LOCK-DOWN MODE FOR ADDED COUPLING SECURITY**

New double acting air cylinder provides a new level of coupling security with an integrated "Lock-Down" mode that is automatically activated when the driver releases the trailer brakes. Prevents the potential for dropped trailers when properly coupled.

**3 REMOVABLE SPRING RETAINER**

Makes for quick and easy removal of the yoke shaft spring. No need to compress the spring by hand to install.



**DOLLY MASTER**

The air-operated, all steel, tractor nose-mounted system provides a fast way to spot converter dollies in the yard. The



nose-mounted system allows for driver visibility to quickly secure, move and release the dolly from within the cab.

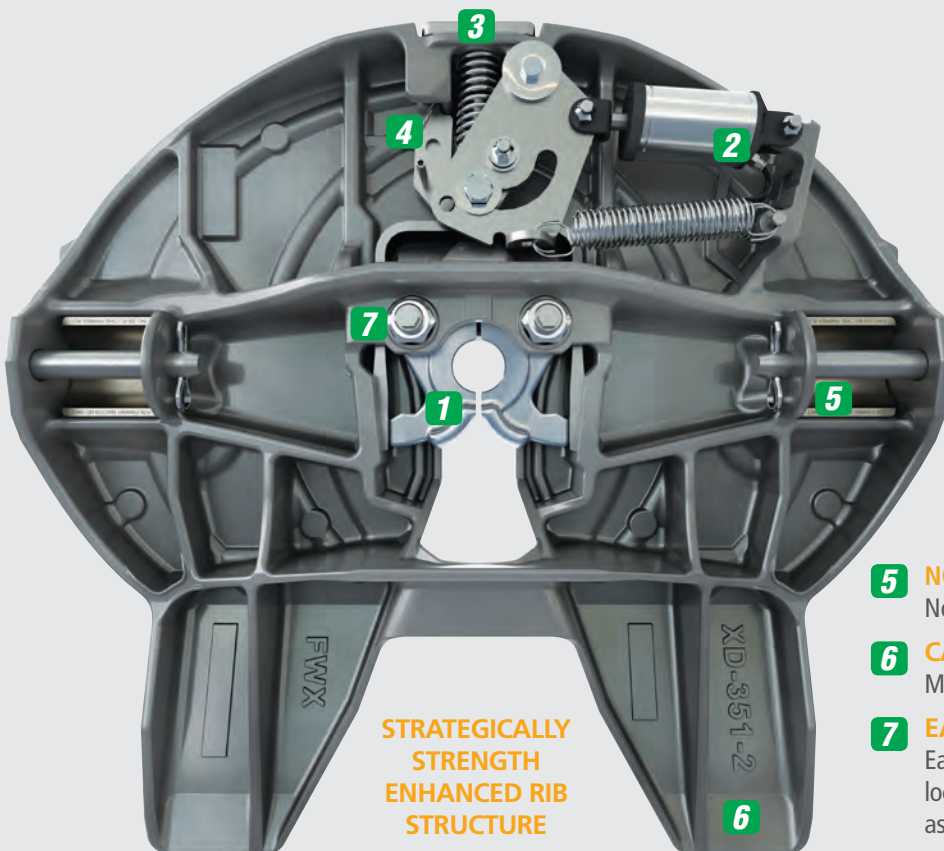

**STRATEGICALLY STRENGTH ENHANCED RIB STRUCTURE**

**4 INTEGRATED AUTOMATIC SECONDARY LOCK**

Eliminates the need for a manual handle activated secondary lock.

**5 NOLUBE™ POCKET LINERS**

NoLube pocket liner inserts with easy to remove clinch pin.

**6 CAST STEEL CONSTRUCTION**

More reliable and forgiving than traditional ductile top plates.

**7 EASY LOCK SET REPLACEMENT**

Easy 15 minute lock set replacement- "Slip-Fit" lock pins with lock nut retention for easy and quick removal. Locks slide out as complete set.



# THE RIGHT CHOICE FOR INTERMODAL CONTAINER CHASSIS TRAILERS



## ATLAS iM™

### LIFT CAPACITY

**65,000 LBS.** (29,485 kg)

#### CAPACITIES

65,000 lbs. Lift Capacity  
(100 ft./lbs. Input Torque)

170,000 lbs. Load Capacity

34,000 lbs. Side Load Capacity\*\*

\*\* Side load capacity rating requires the strut bracket centerline be located no more than 6.5" from the bottom of the upper housing.

## EASY OPERATION WITH RUGGED DURABILITY

- Robust 10 hole mounting plate for durability and added side load protection.
- Gearbox with low temperature lube rated for service from -65°F to 225°F.
- Constant mesh gearbox design provides trouble-free shifting.
- Specially designed shaft seals within gearbox and upper housing keep water out.
- Standard 5-year warranty and performance guarantee.
- Standard RCF removable cushion foot with optional 2" sandshoe.
- HOLLAND landing gear is manufactured and tested to meet or exceed AAR M-931 specifications.



**ULTIMATE  
CORROSION  
PROTECTION**

## HOLLAND Exclusive FloatingNut™ Feature for Longer Service Life

*When excessive side-load forces occur on the landing gear when fully extended, the FloatingNut™ allows the lower leg to move within the upper leg housing without causing permanent damage to the elevating screw.*

*The unique Twin-Bulkheads, above and below the FloatingNut™, provide additional structural strength to the top of the lower leg tube.*



## STANDARD 5-YEAR WARRANTY OR EXTENDED LIFETIME WARRANTY

The HOLLAND iM model is available with standard or extended warranty options.

5-Year warranty covers defects in materials and Workmanship.

Lifetime warranty covers defects in material and workmanship and comes standard with the NoLube™ feature.

The 10-Year NoLube feature also reduces your maintenance bottom line and covers unexpected repairs and associated costs, unless the product is altered or damaged.

Recommended protection practices for your HOLLAND landing gear include routine greasing at 6 month intervals. After 10 years of operation, HOLLAND legs with the 10-Year NoLube feature, require routine greasing every 6 months.

*Note: See warranties for details*

*For 5-year warranty see XL-LG20011WC*

*For Lifetime warranty see XL-LG11395WC*

# THE INDUSTRY'S MOST TRUSTED CONTAINER CHASSIS TRAILER SUSPENSION SYSTEM



## ZF40/ZFX40\* SLIDER SUSPENSION AXLE SYSTEM UP TO 50,000 LBS. CAPACITY (22,680 kg)

with properly specified leaf springs, axle beams, brakes, and wheel ends.

### HIGH-STRENGTH HOLD-DOWNS

Secures the Z-Frame System to the trailer. Compatible with trailer beam flanges up to 3/4" thick and 6" wide.

### HARDENED STEEL WEAR PADS

Included in front and rear hangers to reduce wear and prolong life, preventing hanger failure.



### QwikRelease™ PIN PULL

The low pull effort of the release handle makes slider adjustment safe, easy and efficient. Patented design allows for one driver slider repositioning and eliminates the problem of releasing bound-up pins.



### PIN CAGE DESIGN

Enables easy removal of hold-down bolts and permits the entire slide/suspension system to be removed in minutes. Available in two and four pin configurations.

### \*ZFX40 SYSTEM

Also available with robust 5 3/4" diameter axle with drum or optional P89 disc brakes.

## ZF40 SERIES SPECIFICATIONS

### STANDARD Z-FRAME SUSPENSION

- Ride Heights Available from 13 1/4" to 18"
- Two Pin Slider Positioning
- Optional Four Pin Slider Positioning (90" Spacing)
- Fully Assembled
- 36", 38" and 44" Standard Spring Centers
- 7 1/4" Height Slider Box

### STANDARD SAF DRUM BRAKE AXLE PACKAGE

- 5" Round 7 1/2" Track with ABS Blocks
- Tapered Spindle or Parallel Spindle Axles
- 16 1/2" x 7" Extended Service Brakes
- 28 Spline Brake Cam, 17 3/8" Length

Note: Other Track Lengths and Options Available



## KINGPINS

Since the 1930s, HOLLAND fifth wheels and kingpins have been designed with an integrated "systems" approach to assure years of reliable tractor-trailer connection performance.



HOLLAND kingpins are manufactured and tested to meet or exceed AAR M-931 specifications.



TRAILER AXLES AND  
SUSPENSION SYSTEMS



COUPLING AND  
LIFTING SYSTEMS



SUSPENSIONS FOR  
TRUCKS AND BUSES



SUSPENSIONS AND  
AXLE SYSTEMS



BUS AIR SUSPENSION  
SYSTEMS



V. ORLANDI  
TOWING  
SYSTEMS



TRAILER AXLES/SUSPENSIONS,  
COUPLING AND LIFTING  
SYSTEMS

[safholland.com](http://safholland.com)

**SAF-HOLLAND, Inc.**

888.396.6501 Fax 800.356.3929

**SAF-HOLLAND Canada Limited**

519.537.3494 Fax 800.565.7753

Western Canada 604.574.7491 Fax 614.574.0244