

Important Info – October 2020



SAF Trailer Slider Suspension Systems

SAF-HOLLAND IS GOING GREEN – Transitioning from Printed to Digital Product Literature

Effective Date: Transition Implementation Will Commence January 2021

Continuing our corporate sustainability initiative, SAF-HOLLAND is going digital with product support literature for all SAF trailer slider air and mechanical suspension systems. No longer will printed literature kits be supplied with product shipped from our manufacturing plants.

Product support literature will now be made available through a conveniently located QR code decal. The decal can be found on the slider front hanger for air and mechanical slider suspensions. Accessing literature digitally will assure up-to-date versions.

Scanning of the QR code with your smart device will serve up a menu list of all available technical support literature for that particular product model. Simply click and open the document of your choice.

IMPORTANT: It is recommended that Trailer OEM customers purchase all necessary trailer suspension operator safety and instruction decals in bulk quantities. Please contact your SAF-HOLLAND sales representative to coordinate the ordering process. Ordering decals in bulk will assure availability and efficient application on the OEM assembly line.

EXAMPLE - Slider Suspension Product Support Literature List PDF Accessed Through QR Code

Literature List
SAF® UltraLite & ULX40 Mechanical Slider Suspension

Technical Support Literature List October 2020

This document provides the literature related to the SAF UltraLite Slider and the ULX40 Slider/Axle System. Links to literature PDFs are provided below. Call 800.876.3929 to speak with a customer service representative.

Engineering installation drawings are available upon request through SAF-HOLLAND Trailer Suspension Application Engineering - call 888.396.6501.

UltraLite Slider	Literature PDFs
Installation Manual	XL-MS175
Owner's Manual	XL-MS200318M-en-US
UltraLite Slider Warranty	XL-MS200318WC-en-US
Parts Manual	XL-AM2009PM-en-US

ULX40 Slider/Axle System	Literature PDFs
Owner's Manual	XL-MS200318M-en-US
SAF Tire Pilot Plus Owner's Manual	XL-AS200158M-en-US
SAF Drum Brakes Service Manual	XL-SA10036GM-en-US
SAF P89 Plus Disc Brake Service Manual	XL-SA200144M-en-US
SAF P89 Disc Brake Service Manual	XL-SA200181M-en-US
SAF Tire Pilot Plus Troubleshooting Guide	XL-SA200231S-en-US
Spring Brake Chamber Installation Manual	XL-SA10062IM-en-US
ULX40 Slider Suspension Warranty	XL-MS10204WC-en-US
Parts Manual	XL-AM2009PM-en-US

UltraLite and ULX40 Mechanical Slider Trailer Decals
SAF-HOLLAND provides decals to the Trailer OEM for installation. If missing or damaged, decals can be ordered through SAF-HOLLAND Customer Service - call 800.876.3929 or email amaster@safholland.com. (Please reference part number and description.)

XL-MS189-01 - Maintenance and Torque Specifications
MAINTENANCE & TORQUE SPECIFICATIONS FOR MECHANICAL SUSPENSION

XL-AR356-01 - Tire Clearance Requirements
WARNING

XL-AR429 - Air Pin Pull Repositioning Procedures
WARNING

XL-MS184 - Mechanical Pin Pull Repositioning Procedures
WARNING

ULX40 Only - XL-SA20040DC-en-US - Disc Wheel Installation Procedures
DISC WHEEL INSTALLATION PROCEDURES

CLICK AND VIEW LITERATURE LINKS

Decal with QR Code Located on the Slider Front Hanger

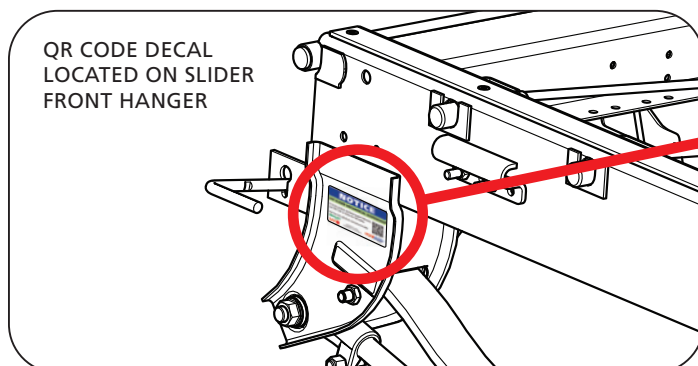

NOTICE

SAF SLIDER MECHANICAL SUSPENSION

To access product technical support literature, scan QR Code or follow the link below.

<http://servicelit.safholland.com/mechanical-slider>

BINKLEY
SAF

XL-MS20057DC-en-US Rev -
Copyright©2020 • SAF-HOLLAND, Inc.

SAF-HOLLAND
Group