

PINTLE HOOK

LATCH REPLACEMENT PROCEDURE

RK-775 Latch Replacement Kit

For PH-775 pintle hook models:

PH-775-01552	PH-775-D
PH-775-E	PH-775-S03964
PH-775-S05086	PH-775-S06589
PH-775-S08011	PH-775-S08758
PH-775-S10128	PH-775-S10454
PH-775-S11178	

VERIFY RK-775 KIT CONTENTS

Description	Part Number	Quantity
A Latch Assembly	XA-764-5A	1
B Pivot Bolt	XA-766-2Z	1
C Slotted Nut	XB-120-2	1
D 1/8" X 1 3/4" Cotter Pin	XB-E-552-1	1
E Never-Seez®*	XB-02967	1
F Zerk Fitting Cap	XB-767-10	2
G 'S' Link	XB-127	1
H 1/4" X 4 1/2" Secondary Lock Cotter Pin	XB-757	1

* Never-Seez is a registered trademark of Bostik, Inc.

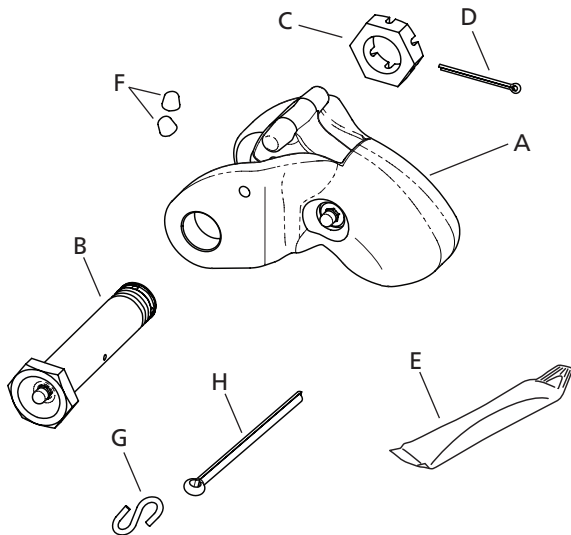

PROCEDURE

1. Remove and discard the old slotted nut and cotter pin, pivot bolt, and latch assembly.

FIGURE 1

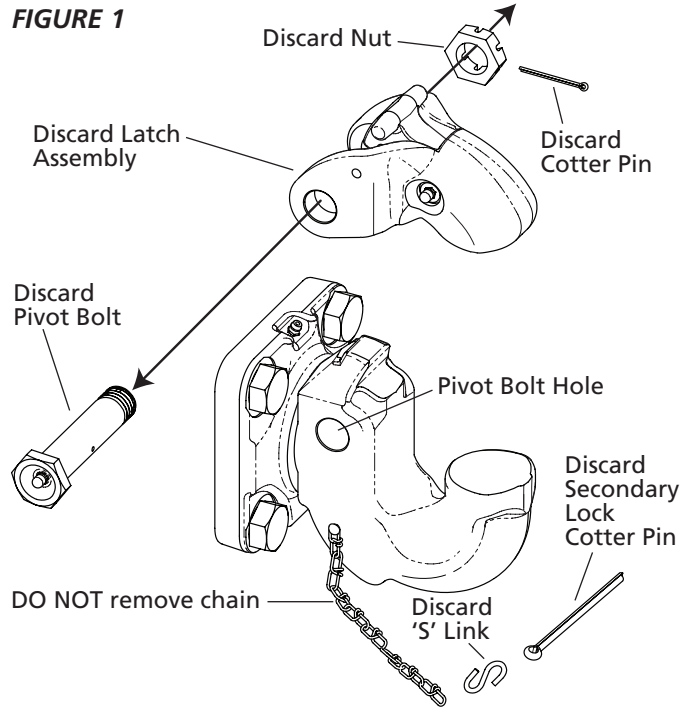

2. Clean accumulated dirt and grease from the pivot bolt hole (Fig 1). Apply Never-Seez® to the entire shaft of the new pivot bolt—not on the threads (FIG 2).

FIGURE 2

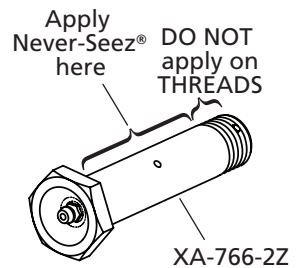

continued

PROCEDURES *continued*

3. Position the new latch assembly (XA-764-5A) over the hook, align the holes for the pivot bolt (XA-766-2Z) and then insert the new bolt through both components. With the pivot bolt fully inserted, screw the new slotted nut (XB-120-2) onto the pivot bolt and torque the connection to 110-135Nm (75-100 ft-lbs).

If necessary, back off the nut **only** enough to align the slot on the nut with the cotter pin hole. Install the smaller cotter pin (XB-E-552-1) through the slotted nut and the hole in the bolt. Spread the cotter pin to secure (**FIG 3**).

Replace Secondary Lock Cotter Pin

1. The secondary lock cotter pin (XB-757) is chained (tethered) to the road-side of the pintle hook. Replace this cotter pin by opening both ends of the 'S' link located between the cotter pin and the chain, then remove and discard both the old 'S' link and cotter pin (**FIG 1**). Install the new cotter pin to the end of the chain using the new 'S' link (XB-127) supplied in the kit. Crimp the 'S' link on both ends to secure the chain and cotter pin together (**FIG 3**).

Check the Latch for proper operation

1. After assembling, the latch should open and close freely. When closed, the lock handle must be fully down, which fully engages the primary lock. Once proper latch operation is verified, a grease gun should be used to re-grease the pivot bolt. The lock pin should be greased at the same time. Small plastic caps are included in this kit and should be installed to protect the ends of the grease zerk fittings (**FIG 4**).

IMPORTANT: Inspect the secondary lock cotter pin on a regular basis to make sure it's in good condition and can readily be inserted through the hole in the latch assembly. The cotter pin must be inserted through both the latch body and lock handle and then secured by bending the split ends. Always insert and secure the secondary lock cotter pin when the pintle hook is in use.

FIGURE 3

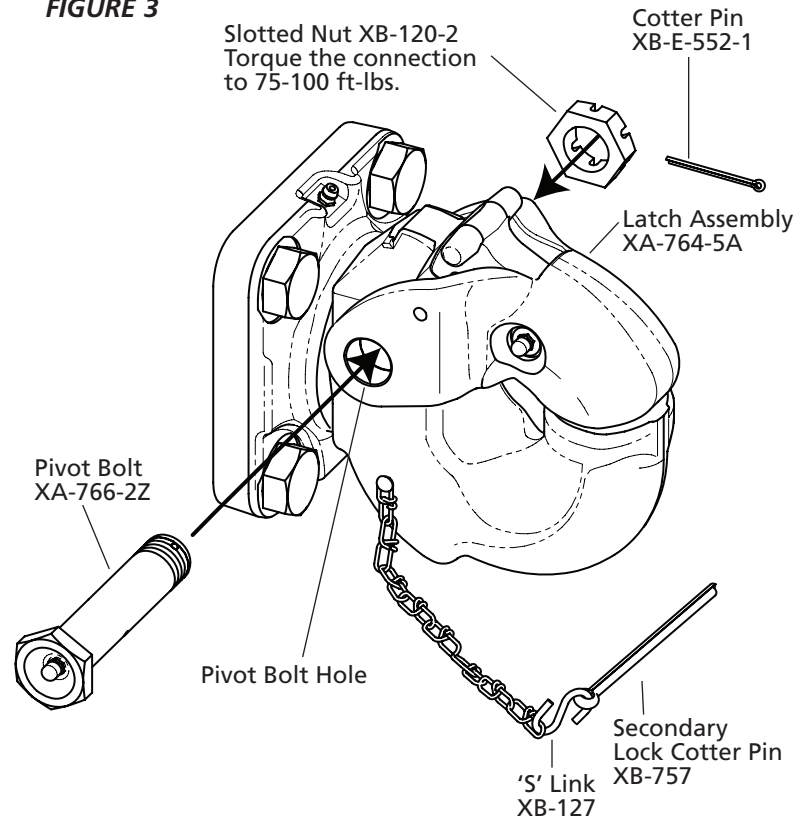
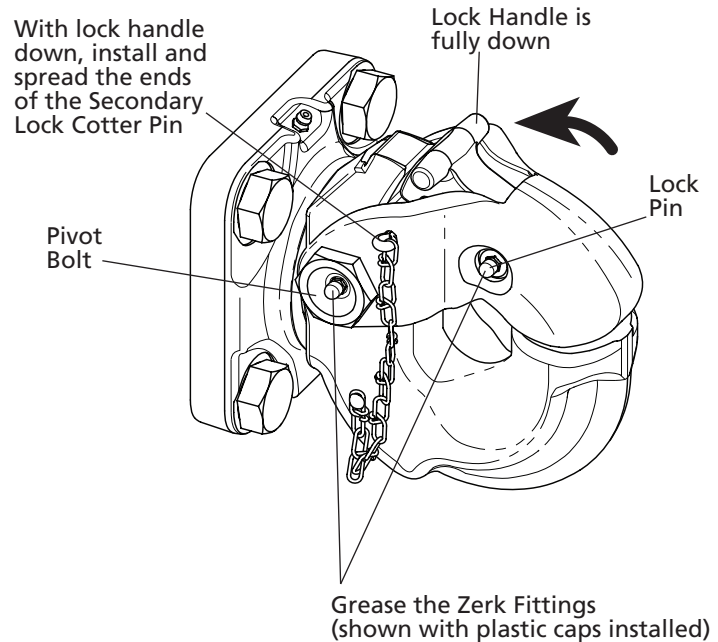

FIGURE 4



SAF-HOLLAND (Aust.) Pty. Ltd. · PO Box 63 · 115 High St · Melton Vic 3337
Tel: (03) 9971 7900 Fax: (03) 9743 6763

Western Australia · Tel: (08) 9353 1720 Fax: (08) 9353 6144
Queensland · Tel: (07) 3375 7033 Fax: (07) 3375 7044
New South Wales · Tel: (02) 9672 1950 Fax: (02) 9672 1994
South Australia · Tel: (08) 8346 7035 Fax: (08) 8346 3583

www.safholland.com.au