



SAF-HOLLAND Group

HOLLAND COUPLING PRODUCTS

PINTLE HOOKS
COUPLERS
DRAW BARS



100 Years in the Design and Manufacturing of Coupling Products



PIONEERING SPIRIT, EXPERIENCE AND INNOVATION

Founded in 1910, the “Safety Release Clevis Company” introduced the first safety release hitch for horse drawn plows. Following a move to Holland, Michigan, the company changed its name to “The Holland Hitch Company” where, in the 1930s, it introduced heavy-duty pintle hooks and drawbars for commercial transportation.



Renamed Holland Group Inc., the company in 2006 merged with the German trailer axle and suspension manufacturer SAF to form SAF-HOLLAND, today one of the leading supplier for the global commercial vehicle industry.

Highly efficient couplers and drawbars for any transport task

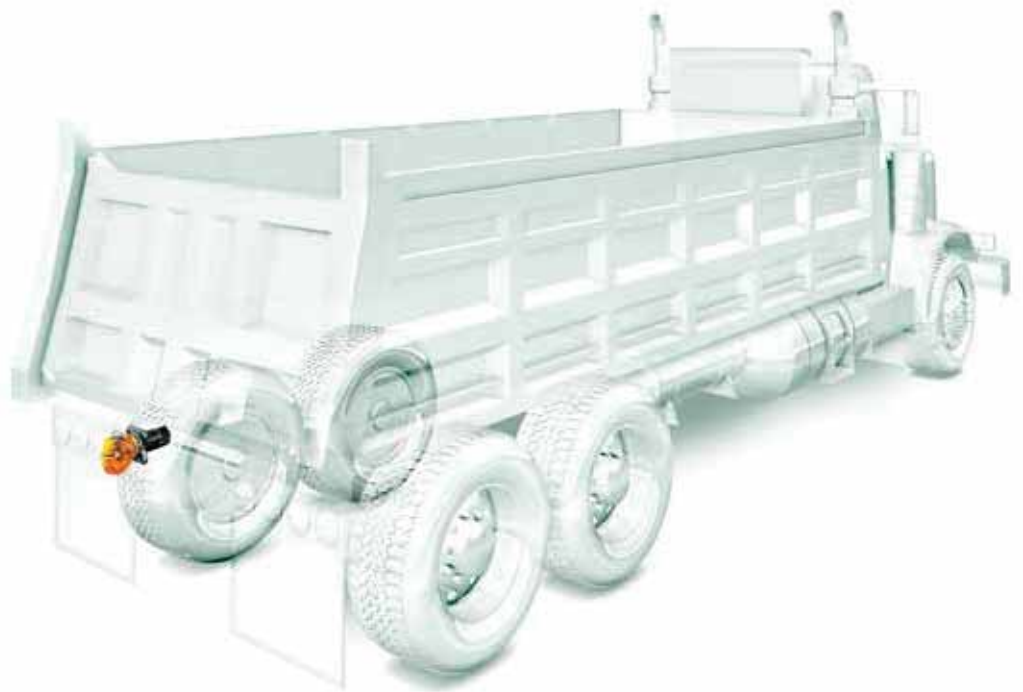

EFFICIENCY, RELIABILITY AND SUPPORT

SAF-HOLLAND products are used millions of times and are proving themselves daily in tough transport conditions worldwide.

All HOLLAND coupling products feature

- Product designed with ISO/TS-16949 certified processes.
Dedicated R & D and Application Engineering Teams
- Full engineering simulation, including FEA of assemblies to optimize product performance
- Dedicated Testing & Analysis facilities that are ISO/TS-16949, DOTARS, and EC certified
- Stringent manufacturing standards and quality controls
- Sales and product support from the global SAF-HOLLAND organization

Pintle Hook PH-419

Application

Heavy-duty 'A' train (converter dolly) applications for bulk liquids, dry bulk, aggregates and quarry materials.

Plunger/snubber force is developed by the vehicle's air system to reduce wear and to provide shock absorption

Available with or without an air chamber and mounting bracket

Air chambers are available with two rod lengths for different mounting widths

Unique one-handed latch operation

Automatic secondary lock for improved safety

Austenitic manganese steel alloy produces hook "work hardening" at the contact surfaces with the drawbar eye

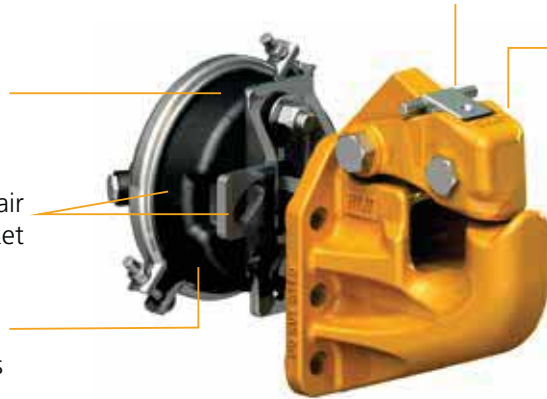

Weight

21.7 kg

Capacities

- 9t Maximum Vertical Load
- 45t Maximum Gross Trailer Weight

Drawbar Eye Dimensions

76 mm I.D. with 32 to 41 mm diameter section

Additional Facts

- The PH-419 body is visibly more robust having been optimized via CAD/FEA for the austenitic manganese material properties
- Tested in accordance with SAE J847

Mounting Dimensions (mm)

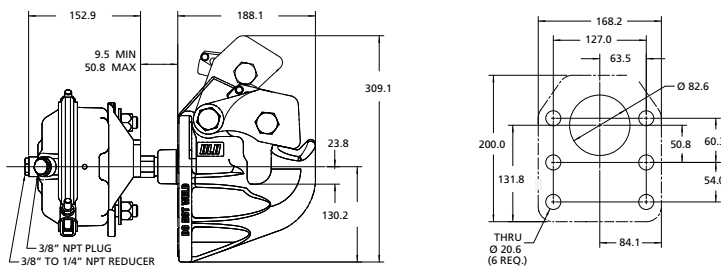

Replacement Parts

RK-10545 LATCH KIT

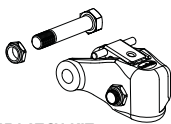

RK-10545-1 LATCH KIT

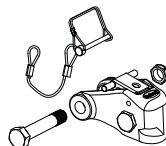

XA-02608 Cylinder and Bracket Sub-Assembly

XB-165945

XE-01544-1

Included with XB-165945

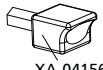
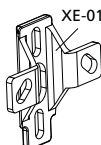
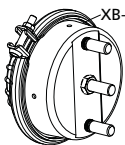

XA-04156

Pintle Hook PH-400



SAF-HOLLAND Group

Application

A rigid mount pintle hook designed for trailers, semitrailers, and doubles and triples operations. Used for off- and over-the-road applications. Air cushioned snubber is designed to minimize the gap between the pintle hook and the drawbar on vehicles with air systems.

Plunger/snubber force is developed by the vehicle's air system to reduce wear and to provide shock absorption

Available with or without an air chamber and mounting bracket

Air chambers are available with two rod lengths for different mounting widths



Unique one-handed latch operation

Automatic secondary lock for improved safety

Cast alloy steel body is heat treated for increased strength, durability, and wear resistance

Threaded plunger is adjustable

Weight

20.8 kg

Capacities

- 9t Maximum Vertical Load
- 45t Maximum Gross Trailer Weight

Drawbar Eye Dimensions

60 to 76 mm I.D. with 32 to 41 mm diameter section

Additional Information

- For off-road applications, reduce the above maximum capacities by 25% and use with a swivel-mount drawbar
- Tested in accordance with SAE J847

Mounting Dimensions (mm)

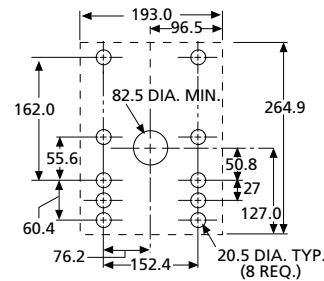
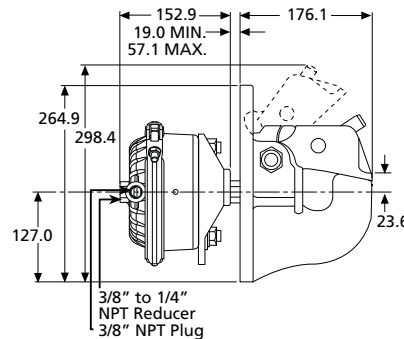

Replacement Parts

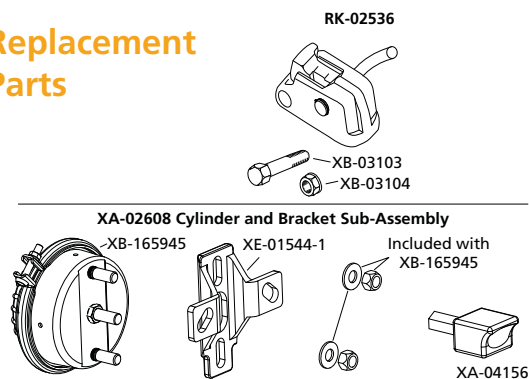

Pintle Hook PH-775-01552

Application

Heavy-duty construction for on- and off-road applications where a significant amount of articulation is required.

Grease fittings for easy lubrication

A one piece housing keeps contaminants from entering the pintle hook assembly

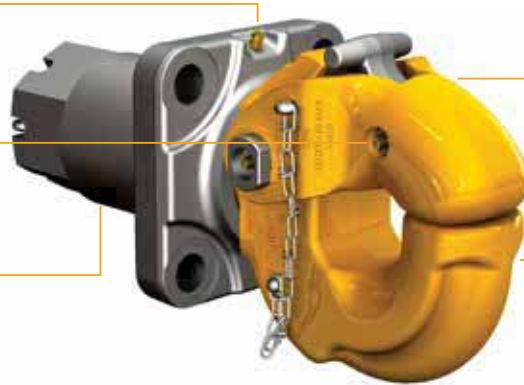

Cast steel alloy latch is heat treated for strength and durability

Body and housing are forged from special steel alloy and heat treated for high strength, and wear resistance

Weight

27.2 kg

Capacities

- 9t Maximum Vertical Load
- 45t Maximum Gross Trailer Weight

Drawbar Eye Dimensions

76 mm I. D. with 41 mm diameter section

Additional Information

- For off-road applications, reduce the above maximum capacities by 25%. Not for use with a swivel-mount drawbar
- Tested in accordance with SAE J847

Mounting Dimensions (mm)

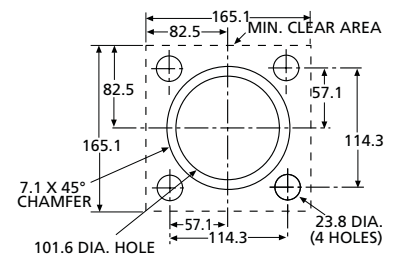
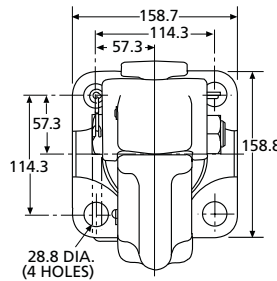
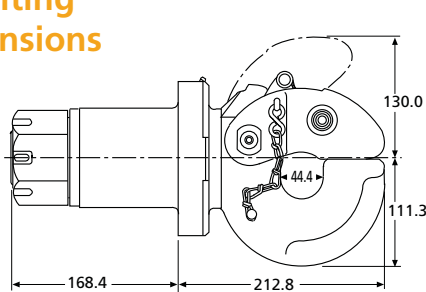

Replacement Parts

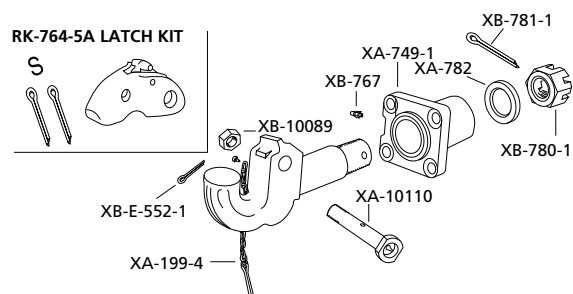

Pintle Hook PH-775SL11

Application

Heavy-duty construction for on- and off-road applications where a significant amount of articulation is required.

The special pintle body shape is designed for maximum articulation and oscillation with reduced wear

Forged from a special steel alloy that is heat treated for strength and durability

NoLube®



FAST LATCH™

One-hand operated latch. Available with a tethered lock pin

Weight

25.85 kg

Capacities

- 9t Maximum Vertical Load
- 45t Maximum Gross Trailer Weight

Drawbar Eye Dimensions

76 mm I.D. with a 41 mm diameter section

Additional Information

- For off-road applications, reduce the above maximum capacities by 25%. Not for use with a swivel-mount drawbar
- Tested in accordance with SAE J847

Mounting Dimensions (mm)

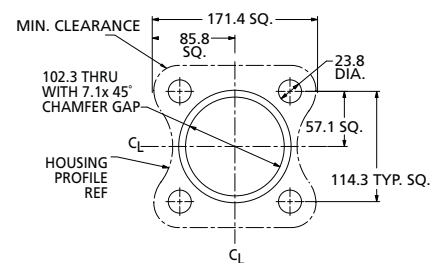
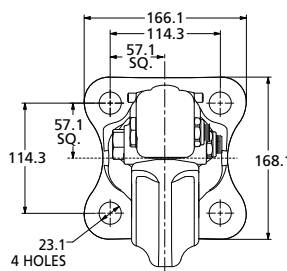
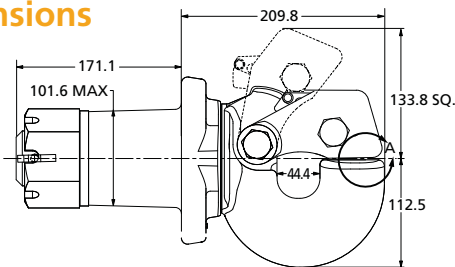

Replacement Parts

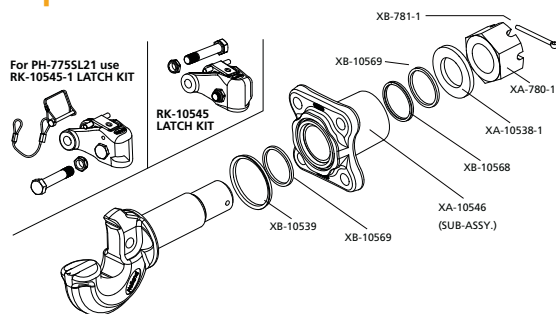

Ball Hitch BH-50

Application

This ball hitch is ideal for heavy-duty over-the-road applications where high articulation (up to 30°) in all directions is required, and in applications where the vehicle and trailer remain coupled. The BH-50 minimizes chucking.

Top-mounted adjustment ratchet provides easier coupling, uncoupling, and slack adjustment.

The release included a compression spring to aid in uncoupling.

Steel bolt-on frame for ease of installation and strength.

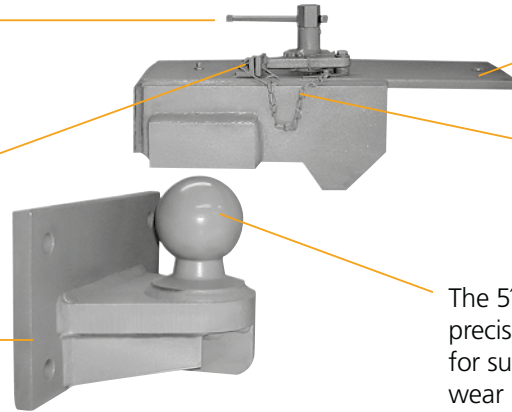

Weld the receiver to the trailer frame or tongue.

The tethered safety pin acts as a secondary lock.

The 5" diameter steel alloy ball is precision machined, and heat treated for superior strength, durability and wear resistance.

Weight

61.2 kg

Capacities

- 3.63t Maximum Vertical Load
- 36t Maximum Gross Trailer Weight

Additional Information

- For additional specification detail, refer to document number XL-PH254.

Mounting Dimensions

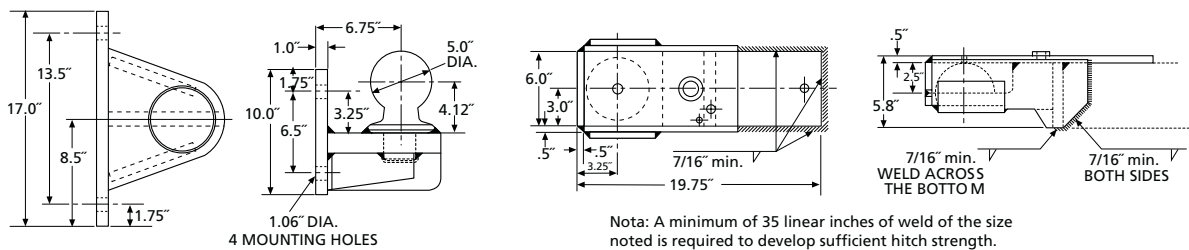

Replacement Parts

RECEIVER ONLY XA-04430

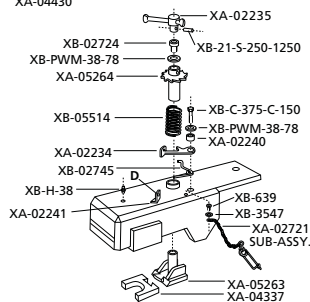

BALL ONLY XA-04108



RK-06683



Pintle Hook PH-T-60-AOL-8

Application

Rigid type pintle hook.

Forged from a special steel alloy that is heat treated for strength and durability



The latch is forged steel alloy and heat treated for strength and long life

Weight

4.4 kg

Capacities

- 2.7t Maximum Vertical Load
- 13.5t Maximum Gross Trailer Weight

Drawbar Eye Dimensions

51 to 76 mm I.D. w. 32 to 41 mm diameter section.

Additional Information

- For off-road applications, reduce the above maximum capacities by 25 % and use with a swivel-mount drawbar
- Tested in accordance with SAE J847

Mounting Dimensions

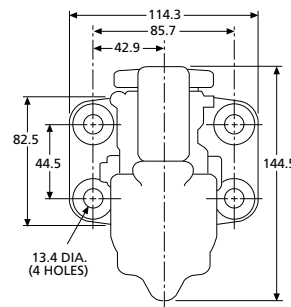
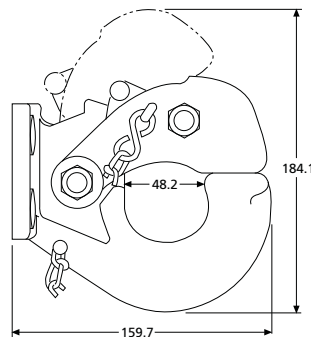

Replacement Parts

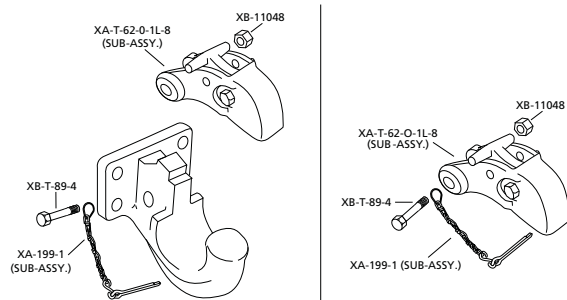

Pintle Hook PH-30RP41

Application

A versatile rigid mount pintle hook designed for over-the-road and off-road towing.

Forged from a special steel alloy that is heat treated for strength and durability



FAST LATCH™

One-hand operated latch. Available with a tethered lock pin

Weight

3.8 kg

Capacities

- 2.7t Maximum Vertical Load
- 13.5t Maximum Gross Trailer Weight

Drawbar Eye Dimensions

60 to 76 mm I.D. w. 31 to 41 mm diameter section.

Additional Information

- For off-road applications, reduce the above maximum capacities by 25 % and use with a swivel-mount drawbar
- Tested in accordance with SAE J847

Mounting Dimensions (mm)

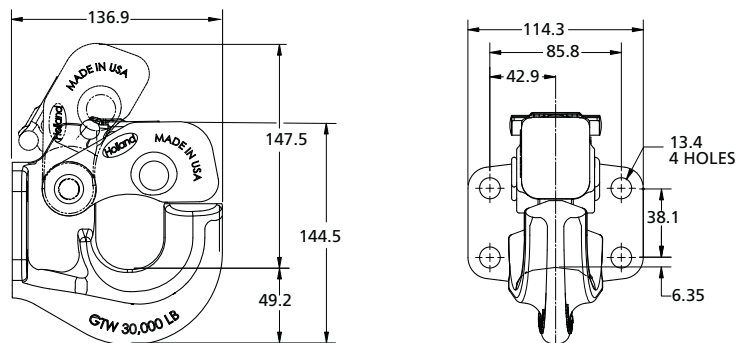

Replacement Parts

For PH-30RP41 use RK-10632

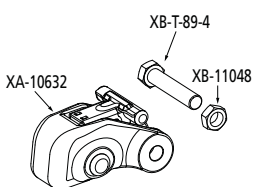

For PH-30RP51 use RK-10632-1

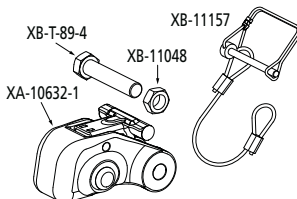

Draw Bar DB-100FQ1

Application

This unique heavy duty drawbar is used on trailers, semi-trailers (including doubles), for on- and off-road towing applications.

Use 22 mm Grade 8 fasteners

Forged from a special steel alloy that is heat treated for strength and durability. Heat treated for strength. I.D. of eye is induction hardened for wear resistance



The drawbar eye is 76 mm I.D. with a 41.4 mm diameter cross section. The eye shape is designed to match HOLLAND pintle horns or coupler jaws to assure minimal wear.

Weight

9.2 kg

Capacities

- 2.7t Maximum Vertical Load
- 13.5t Maximum Gross Trailer Weight

Drawbar Eye Dimensions

76 mm I.D. with 41 mm diameter section

Additional Information

- When used with hinged tongue trailers, where the maximum vertical load cannot exceed 227 kg, the maximum gross trailer weight is 56.7 tons
- For off-road applications, reduce the above max. capacities by 25% and use with swivel-mount coupling device.
- Tested in accordance with SAE J847

Mounting Dimensions (mm)

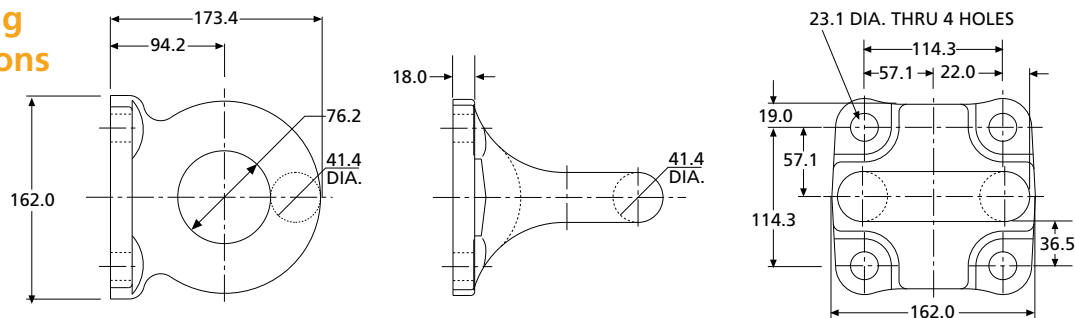

Draw Bar DB-1249-49

Application

Forged one-piece steel alloy drawbar, heat treated for strength. I.D. of eye is induction hardened for wear resistance.



Weight

10.3 kg

Capacities

- 4t Maximum Vertical Load
- 20.4t Maximum Gross Trailer Weight

Drawbar Eye Dimensions

76 mm I.D. with 41 mm diameter cross section

Additional Information

- When used with hinged tongue trailers, where the maximum vertical load cannot exceed 227 kg the maximum gross trailer weight is 38.5 tons
- For off-road applications, reduce the above maximum capacities by 25 %

Mounting Dimensions (mm)

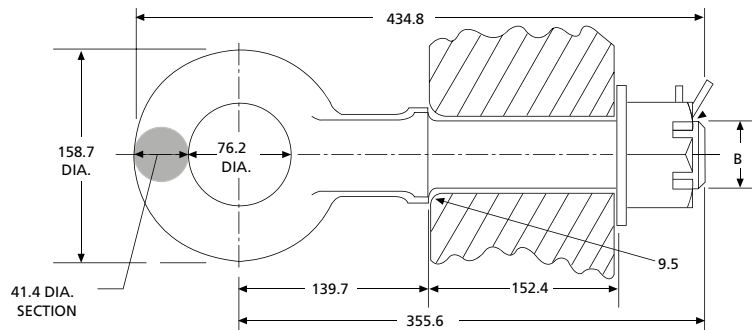

Note:

The mounting surface must have an adequate chamfer, so that the drawbar mounts flush with the mounting surface.

Replacement Parts

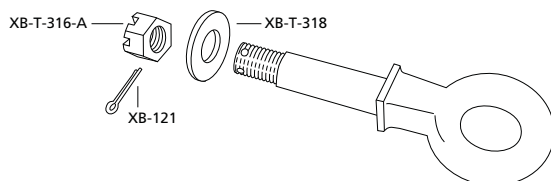

Draw Bar DB-1235-1



SAF-HOLLAND Group

Application

Forged one-piece steel alloy drawbar, heat treated for strength. I.D. of eye is induction hardened for wear resistance.



The eye shape is designed to match Holland pintle horns or coupler jaws to assure minimal wear

Weight

20.6 kg

Capacities

- 3.15t Maximum Vertical Load
- 15.42t Maximum Gross Trailer Weight

Drawbar Eye Dimensions

76 mm I.D. w. 41 mm diameter section

Additional Information

- When used with hinged tongue trailers, where the maximum vertical load cannot exceed 227 kg, the maximum gross trailer weight is 40.8 tons
- For off-road applications, reduce the above maximum capacities by 25% and use with a swivel-mount coupling device

Mounting Dimensions (mm)

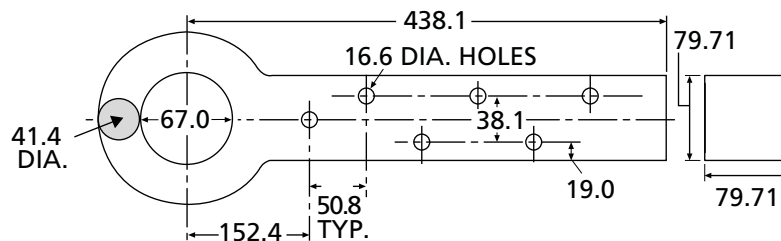

Important:

Do not weld!
Not designed to be welded to a trailer tongue.

Mounting

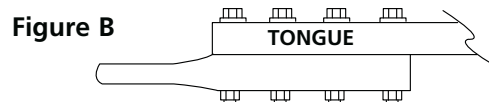
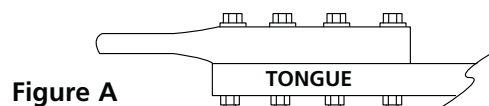

The capacities published for these drawbars are based on an over-tongue mount as shown in **Figure A**. If mounted under-tongue, as in **Figure B**, the vertical rating may be increased by 50%. The hinged tongue rating is not affected by over/under tongue mounting.



From fifth wheel rebuild kits to suspension bushing repair kits, SAF-HOLLAND Original Parts are the same quality components used in the original component assembly. SAF-HOLLAND Original Parts are tested and designed to provide maximum performance and durability. Will-fits, look-alikes or, worse yet, counterfeit parts will only limit the performance potential and could possibly void SAF-HOLLAND's warranty.

Always be sure to spec SAF-HOLLAND Original Parts when servicing your SAF-HOLLAND product.

XL-PH1048851-en-US Rev B · 2013-10-01 · Amendments and Errors Reserved ©SAF-HOLLAND, Inc.
SAF-HOLLAND, HOLLAND, FAST LATCH, and SAF-HOLLAND Original Parts logos are trademarks of SAF-HOLLAND S.A., SAF-HOLLAND GmbH, and SAF-HOLLAND, Inc.

HIGH QUALITY COMPONENTS FOR THE COMMERCIAL VEHICLE INDUSTRY

AXLES & SUSPENSION

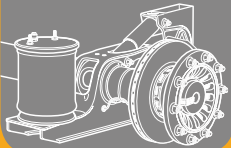

LANDING GEAR

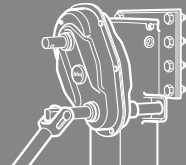

KINGPINS



FIFTH WHEELS

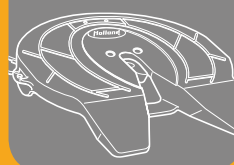

COUPLING PRODUCTS

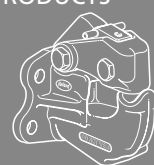

EUROPE · NORTH AMERICA · SOUTH AMERICA · AFRICA · ASIA · AUSTRALIA

SAF-HOLLAND do Brasil

Av. Emílio Marconato, 1000 · Galpão B-16, Chácara Primavera · 13.820-000 Jaguariuna - SP
Tel. + 55 19 3311-1572 · Fax + 55 19 3311-1554 · vendas@safholland.com.br

www.safholland.com.br

