

## Owner's Manual

### PH-405 Series Rigid Type Pintle Hook

Installation, Operation and Maintenance Procedures

- Can be used with or without an air chamber/plunger
- Maximum GTW: 100,000 lb. (45,359 kg)
- Maximum Vertical Load: 20,000 lb. (9,072 kg)
- Weight (Approx.): 34 lb. (15 kg) Pintle Hook only

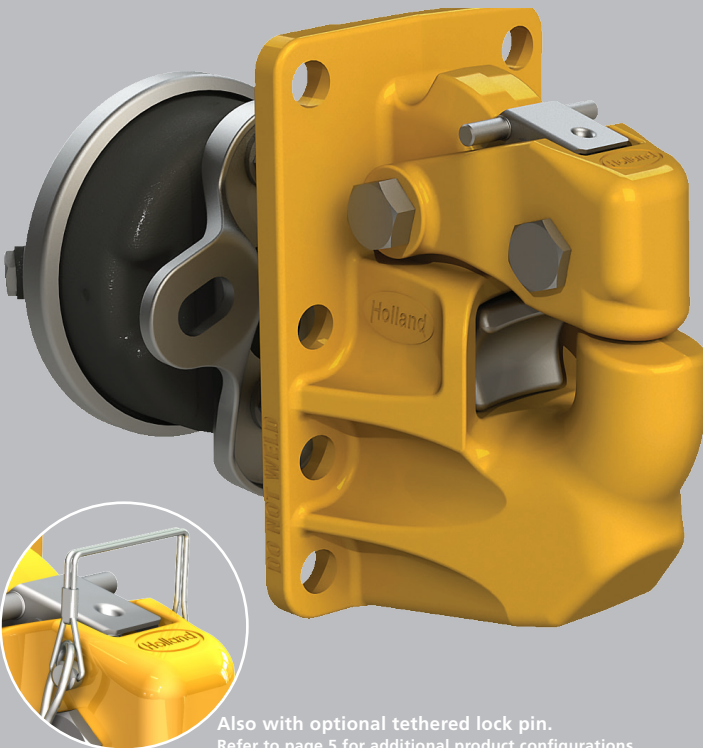

Also with optional tethered lock pin.  
Refer to page 5 for additional product configurations.

Product covered by one or more United States  
or Foreign Patents.

Contents	Page
Introduction.....	2
Warranty.....	2
Notes, Cautions, and Warnings.....	2
Important Safety Instructions.....	3
Exploded View.....	4
Parts List.....	5
Mounting Structure Chart.....	5
Dimensions.....	5
Section 1 – Drawbar Eye Dimensions.....	6
Section 2 – Load Ratings per SAE J847.....	6
Section 3 – Towing Applications.....	6

Contents	Page
Section 4 – Installation Options.....	6
Section 5 – Pintle Hook Only Mounting Instructions.....	7
Section 6 – Pintle Hook, Air Chamber with Bracket Mounting Instructions.....	8
Section 7 – Pintle Hook, Air Chamber without Bracket Mounting Instructions.....	10
Section 8 – Plunger Adjustment.....	12
Section 9 – Operating Instructions.....	13
Section 10 – Maintenance.....	14
Section 11 – Replacement Latch Kit.....	15

## Introduction

This manual provides information necessary for the proper mounting, operation, maintenance, and inspection of the SAF-HOLLAND® pintle hook.

**NOTE:** For HOLLAND® replacement components contact SAF-HOLLAND® Customer Service: 1-888-396-6501.

## Warranty

This product is covered by SAF-HOLLAND’s® Coupling Products Commercial Warranty. Refer to the complete warranty for the country in which the product will be used. A copy of the written warranty can be downloaded from our SAF-HOLLAND® website ([www.safholland.us](http://www.safholland.us)).

## Notes, Cautions, and Warnings

Read and understand all of the procedures presented in this manual before starting any work on the pintle hook.

**NOTE:** In the United States, work shop safety requirements are defined by federal and/or state Occupational Safety and Health Act. Equivalent laws could exist in other countries. This manual is written based on the assumption that OSHA or other applicable employee safety regulations are followed by the location where work is performed.

Proper tools **MUST** be used to perform the mounting and maintenance procedures described in this manual.

This manual contains the terms “NOTE”, “IMPORTANT”, “CAUTION”, and “WARNING” followed by important product information. These terms are defined as follows:

**NOTE:** Includes additional information to enable accurate and easy performance of procedures.

**IMPORTANT:** Includes additional information that if NOT followed could lead to hindered product performance.

**CAUTION** Used without the safety alert symbol, indicates a potentially hazardous situation which, if not avoided, could result in property damage.

**CAUTION** Indicates a potentially hazardous situation which, if not avoided, could result in minor or moderate injury.

**WARNING** Indicates a potentially hazardous situation which, if not avoided, could result in death or serious injury.

## Important Safety Instructions

**IMPORTANT:** Read this manual before using this product. Keep this manual in a safe location for future reference.

**⚠ WARNING** Failure to follow the instructions and safety precautions in this manual can result in equipment failure which, if not avoided, could result in death or serious injury.

Maintain sufficient vertical (tongue) load to adequately control the trailer (generally 10% of the gross vehicle weight) but DO NOT exceed the capacity ratings listed in Section 2, page 6.

The equipment listed in this manual MUST NOT be used or maintained in a careless manner.

### During Operation:

1. Ensure that the drawbar sizes are compatible with the coupling device on the tow vehicle.
2. DO NOT damage the latch. Be particularly careful during coupling and uncoupling. Make sure that the pintle hook latch closes and locks properly.
3. Inspect the coupling device on the tow vehicle for proper operation. DO NOT use any coupling device that DOES NOT operate properly.

Front

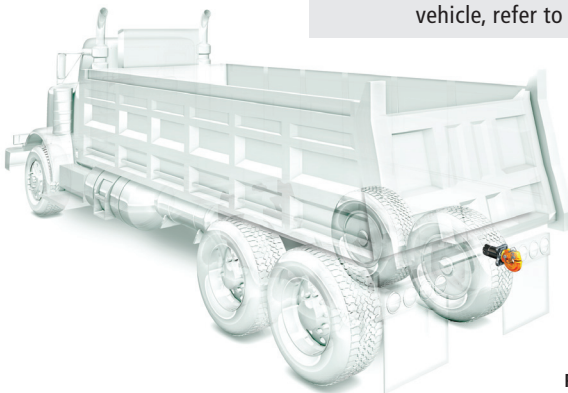

Rear

4. Other steps and inspections are also required. Consult OSHA and D.O.T. regulations and the American Trucking Association for complete coupling and uncoupling procedures. These cover items such as cargo securement, brakes, lights, safety chains, and other important requirements.

### General Information:

1. DO NOT modify or add to these products.

**⚠ CAUTION** DO NOT hit steel parts with a steel hammer as parts could break, sending flying steel fragments in any direction creating a hazard which, if not avoided, could result in minor to moderate injury.

2. DO NOT weld on these products.

**IMPORTANT:** Bolts MUST be long enough to provide a minimum of two (2) full thread lengths beyond the end of the nut.

**⚠ WARNING** Failure to use a long enough bolt for mounting pintle hook, could result in vehicle and trailer separation which, if not avoided, could result in death or serious injury.

**NOTE:** In this manual, all descriptions of orientation are relative to the vehicle, refer to image below.

PH-775SLII Shown

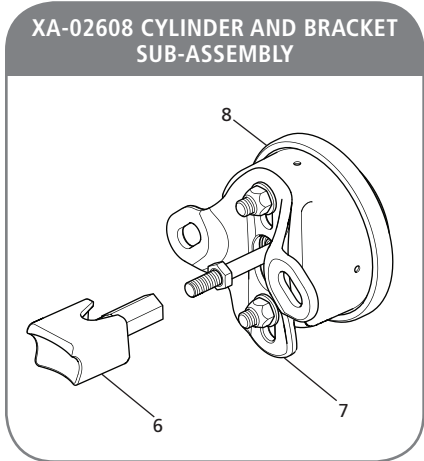
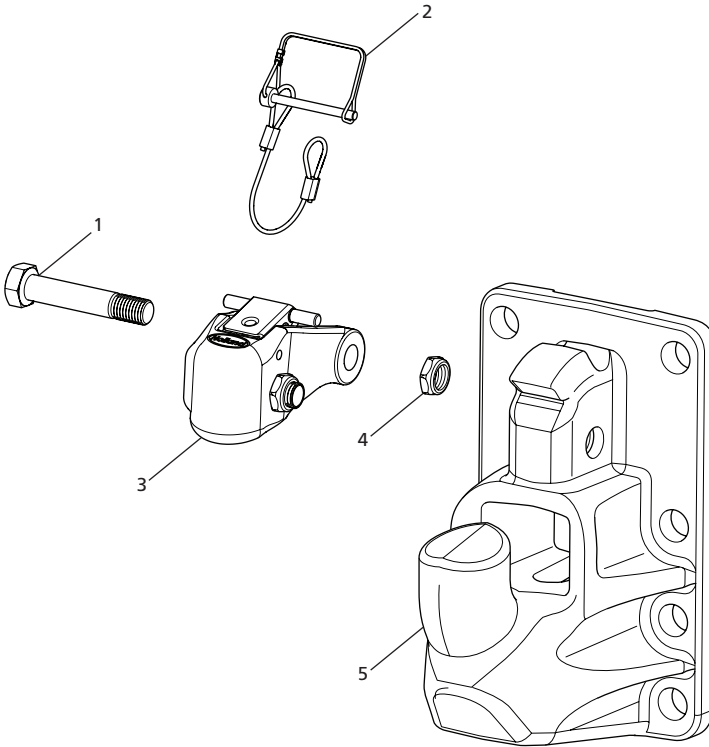

ITEM	PART NUMBER	QTY.	DESCRIPTION
1	XB-10537	1	HHCS 3/4"-16 x 4" LG. (Latch Bolt)
2	XB-11895-75	1	Pin and Lanyard S/A (Tethered Lock Pin)
3	XA-10545 or XA-10545-2	1	Assembly Latch Heavy Duty Tethered
4	XB-03104	1	Nut, Lock 3/4"-16 (Latch Nut)

ITEM	PART NUMBER	QTY.	DESCRIPTION
5	XD-12154	1	Frame, Pintle Hook
6	XD-04156	1	Plunger S/A
7	XA-11525	1	Bracket, Air Chamber
8	Refer to Chart Below	N/A	Air Chamber

**Note:** Individual component parts NOT for sale.

## MOUNTING STRUCTURE CHART

ASSEMBLY CONFIGURATION	PINTLE ASSEMBLY NUMBER	MOUNTING STRUCTURE WIDTHS "X" (REFER TO DIMENSIONS BELOW)	AIR CHAMBER ROD LENGTH	AIR CHAMBER AND PLUNGER KIT NUMBER	AIR CHAMBER PART NUMBER
Pintle Hook with Air Chamber	PH-405RA11	0.38" (9.7 mm) - 2.5" (63.5 mm)	1.8" (45.7 mm)	XA-02608	XB-165945
Pintle Hook with Air Chamber	PH-405RA21	0.38" (9.7 mm) - 2.5" (63.5 mm)	1.8" (45.7 mm)	XA-02608	XB-165945
Pintle Hook with Air Chamber	PH-405RF11	14.0" (355 mm) MAX	12.0" (304.8 mm)	XA-10198	XB-166321
Pintle Hook with Air Chamber	PH-405RF21	14.0" (355 mm) MAX	12.0" (304.8 mm)	XA-10198	XB-166321
Pintle Hook with Plunger Only	PH-405RM11	Refer to Section 6 and 7	N/A	N/A	N/A
Pintle Hook with Plunger Only	PH-405RM21	Refer to Section 6 and 7	N/A	N/A	N/A
Pintle Hook Only	PH-405RN11	Refer to Section 5	N/A	N/A	N/A
Pintle Hook Only	PH-405RN21	Refer to Section 5	N/A	N/A	N/A

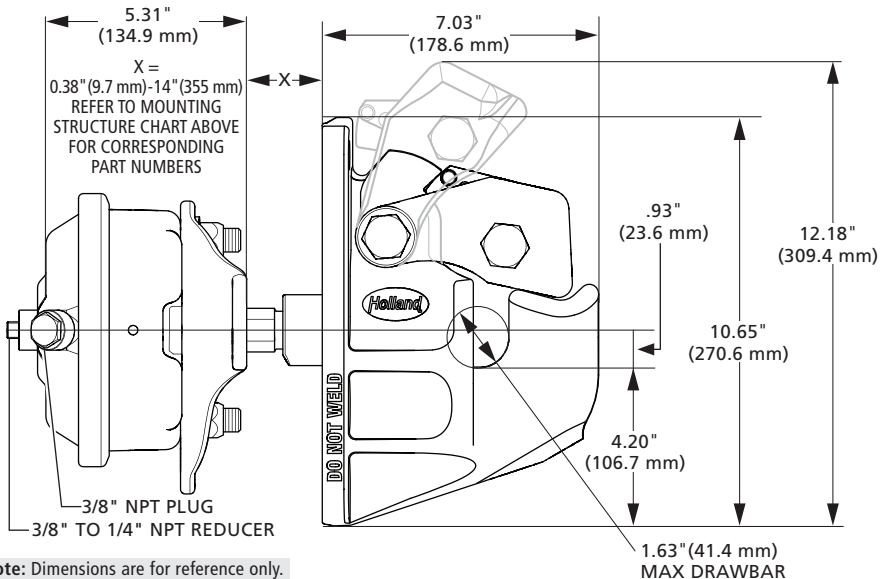

**Note:** Dimensions are for reference only.

## 1. Drawbar Eye Dimensions

3" (76.2 mm) I.D. with a 1.63" (41.3 mm) diameter cross section.

## 2. Load Ratings Per SAE J847

This product meets or exceeds the testing requirements for SAE J847 Type II Loads.

Maximum GTW: 100,000 lb. (45,359 kg)

Maximum Vert. Load: 20,000 lb. (9,072 kg)

Also meets Proj-Nom-035-SCT-2-2008 Trailers and Semi-trailers – Specifications of Safety and Test Methods (Proy-Nom-035-SCT-2-2008 Remolques y Semirremolques – Especificaciones de seguridad y metodos de prueba.)

## 3. Towing Applications

Truck/trailer operations are within the stated capacities. For off-road applications, reduce the above capacities by 25% and use in conjunction with a swivel type drawbar.

**IMPORTANT:** Off-road refers to terrain on which a tractor-trailer operates which is unpaved and rough, or ungraded. Any terrain NOT considered part of the system of public roads falls under this heading.

## 4. Installation Options

The PH-419 rigid mount pintle hook is available in four (4) configurations: pintle hook only, (Section 5); pintle hook, plunger and air chamber with bracket, (Section 6); pintle hook with plunger and air chamber no bracket (Section 7), and pintle hook with plunger only (Section 7). Each configuration requires a different installation which is described in the following sections. Be sure to verify your configuration before beginning installation.

## 5. Pintle Hook Only Installation

Before installing the pintle hook (**Figure 1**), make sure that the mounting structure is of sufficient strength to support the rated capacity of the pintle hook. Refer to SAE J847 for structural performance requirements.

1. Install the pintle hook to the mounting structure using the bolt hole pattern as specified (**Figure 3**).
2. Verify the mounting structure hole pattern matches the dimensions listed (**Figure 3**).
3. Insert and tighten all eight (8) new 3/4" diameter Grade 8 bolts, ASTM Grade C lock nuts and hardened 3/4" washers (**Figure 2**). Torque to 200 ft.-lbs. (271 N•m).

**Figure 1**

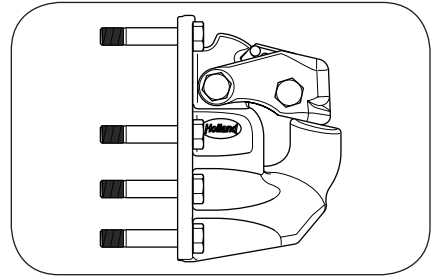

**Figure 2**

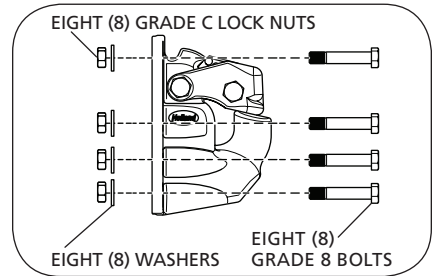

**Figure 3**

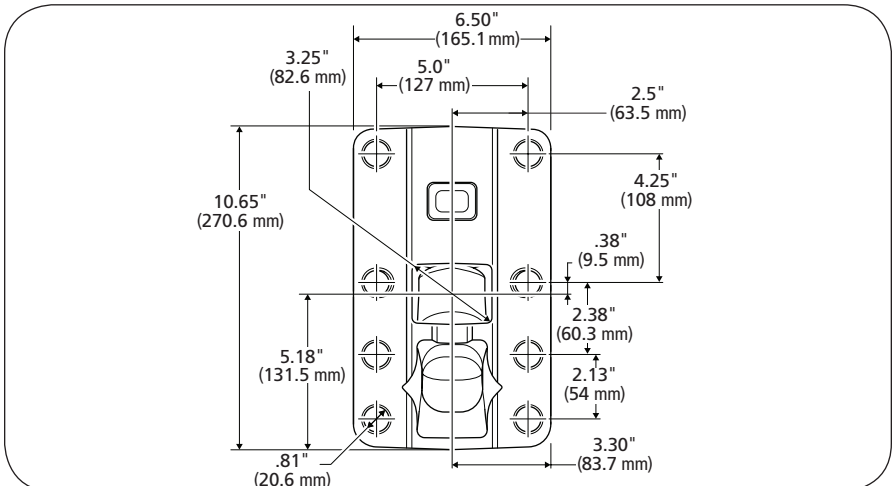

## 6. Pintle Hook, Plunger, and Air Chamber with Bracket Installation

**NOTE:** HOLLAND® recommends a Type 24 air chamber.

Before installing the pintle hook (**Figure 4**), make sure that the mounting structure is of sufficient strength to support the rated capacity of the pintle hook. Refer to SAE J847 for structural performance requirements.

1. Install the pintle hook with the air chamber and bracket to the mounting structure using the bolt hole pattern as specified (**Figure 6**).
2. Verify the mounting structure hole pattern matches the dimensions listed (**Figure 6**).
3. Insert the bottom four (4) and top two (2) bolts of the pintle hook using six (6) new 3/4" diameter Grade 8 bolts, ASTM Grade C lock nuts, and hardened 3/4" washers (**Figure 5**).

**Figure 4**

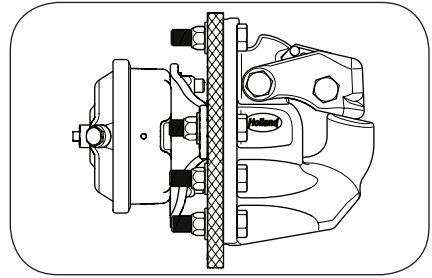

**Figure 5**

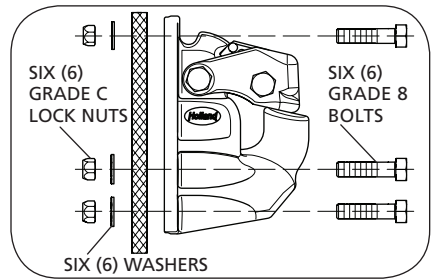

**Figure 6**

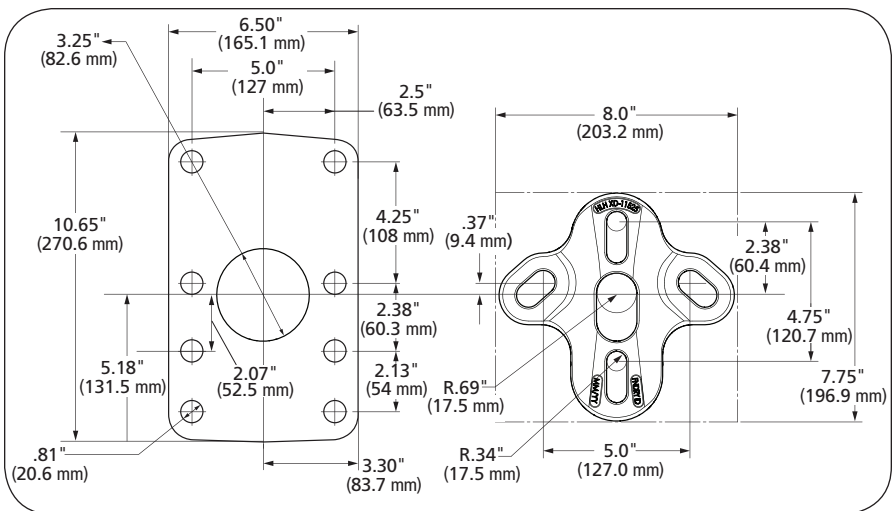



4. Install the air chamber by aligning the air chamber assembly and plunger with the pintle hook. Ensure that the plunger moves freely within the pintle hook plunger chamber (**Figure 7**). Plunger preset to accept mounting plate thickness up to 1.75" (44.5 mm) thick. Bolt together the air chamber assembly and pintle hook using two (2) new 3/4" diameter Grade 8 bolts, ASTM Grade C lock nuts, and hardened 3/4" washers (**Figure 8**).
5. Torque all eight (8) new 3/4" diameter Grade 8 bolts and ASTM Grade C lock nuts to 200 ft.-lbs. (271 N•m)
6. Connect the air supply to the air chamber and check for proper operation.

**IMPORTANT:** Consult the vehicle manufacturer for information regarding proper plumbing, air source, and overpressure protection.

7. Adjust the plunger as needed per detailed instructions in Section 8, page 12.

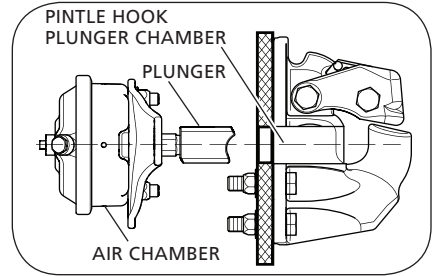
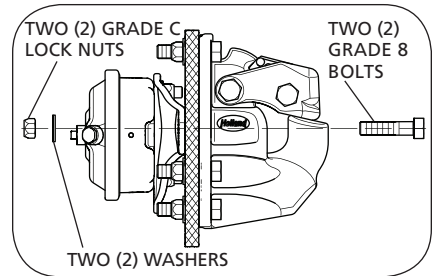
**Figure 7**

**Figure 8**

## 7. Pintle Hook, Plunger with Air Chamber No Bracket Installation

**IMPORTANT:** HOLLAND® recommends a Type 24 air chamber.

Before installing the pintle hook (**Figure 9**), make sure that the mounting structure is of sufficient strength to support the rated capacity of the pintle hook. Refer to SAE J847 for structural performance requirements.

1. Install the pintle hook to the mounting structure, using the mounting bolt hole pattern specified (**Figure 11**).
2. Verify the mounting structure hole pattern matches the dimensions listed (**Figure 11**).
3. Insert and tighten all eight (8) new 3/4" diameter Grade 8 bolts, ASTM Grade C lock nuts and hardened 3/4" washers (**Figure 10**). Torque to 200 ft.-lbs. (271 N•m).

**Figure 9**

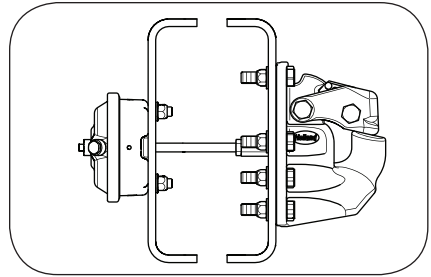

**Figure 10**

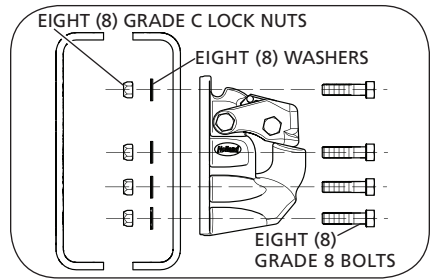

**Figure 11**

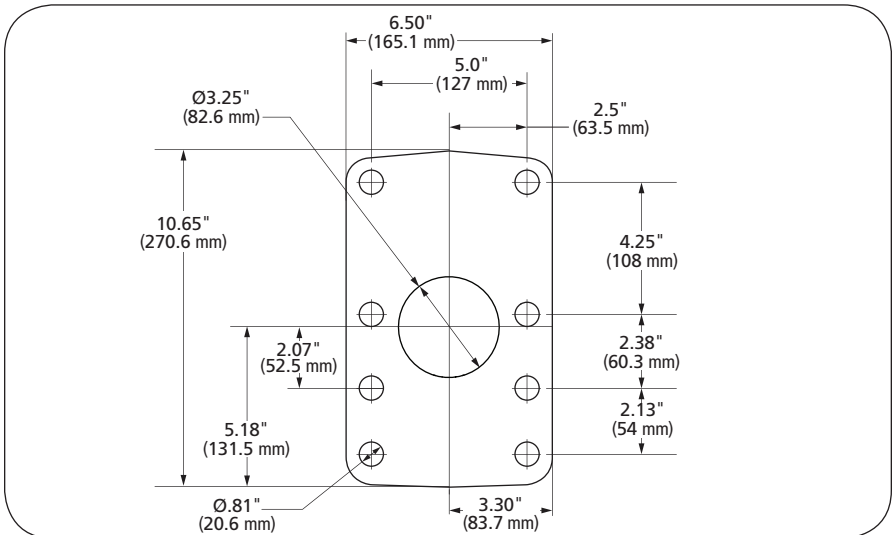

4. Install the air chamber by aligning the air chamber assembly and plunger with the pintle hook. Ensure that the plunger moves freely within the pintle hook plunger chamber (**Figure 12**).
5. Connect the air supply to the air chamber and check for proper operation.

**IMPORTANT:** Consult the vehicle manufacturer for information regarding proper plumbing, air source, and overpressure protection.

6. Adjust the plunger as needed per detailed instructions in Section 8, page 12.

**Figure 12**

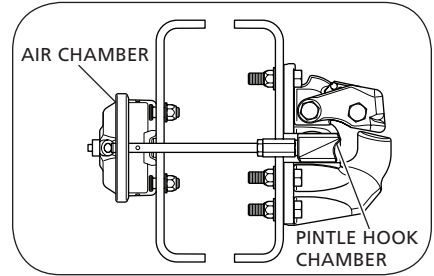

## 8. Plunger Adjustment

When properly adjusted, the plunger should tightly grip a 1.25" (31.8 mm) round bar (**Figure 13**) when activated and retract far enough when de-activated to allow easy removal of a 1.63" (41.4 mm) diameter drawbar.

1. To adjust the plunger, loosen the jam nut from the plunger rod and rotate the plunger rod to increase or decrease the plunger engagement (**Figure 14**).

**IMPORTANT:** HOLLAND® plungers are pre-set at the factory to provide approximately 1" (25.4 mm) of adjustment. At NO time should the push rod have less than .38" (9.5 mm) engagement with the plunger (**Figure 14**).

2. After adjusting the plunger, retighten the jam nut securely against the plunger adjustment nut.

**Figure 13**

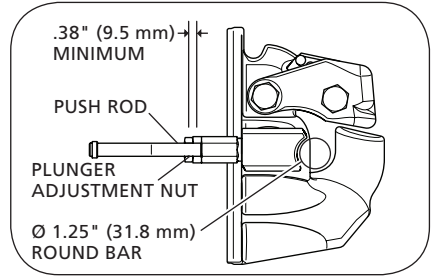

**Figure 14**

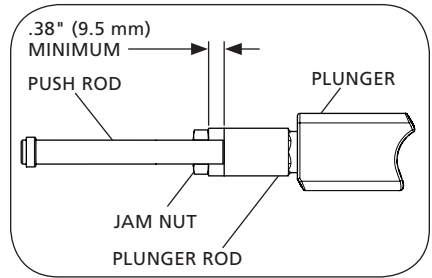

## 9. Operating Instructions

Before operating, check for worn, damaged, or missing parts, and make sure the mount is secure.

**⚠ WARNING** If the pintle hook is NOT secured to the mounting surface, the pintle hook could separate from the vehicle which, if not avoided, could result in death or serious injury.

1. Unlock and remove the tethered lock pin, if applicable (**Figure 15**).
2. Lift the lock handle away from the vehicle until the lock clears the lock seat on the hook body. Open the latch by rotating the latch assembly up toward the vehicle until the latch is in its most upright position, then release the lock handle. (**Figure 16 and 17**).
3. Position the drawbar eye over the horn of the pintle hook and lower it into place.
4. Push the latch closed. When correctly locked, the lock handle will rotate and move up until it is flush with the top of the latch (**Figure 18**).
5. Insert the tethered lock pin through the latch and lock holes, and close the tethered wire lock pin, if applicable (**Figure 15**).

**⚠ WARNING** Failure to correctly lock the latch can result in separation of the trailer and vehicle which, if not avoided, could result in death or serious injury.

**Figure 15**

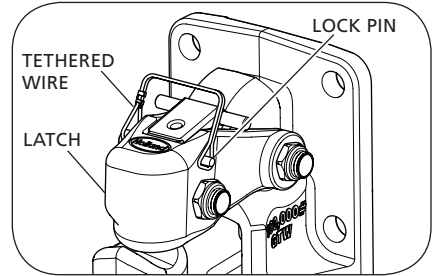

**Figure 16**

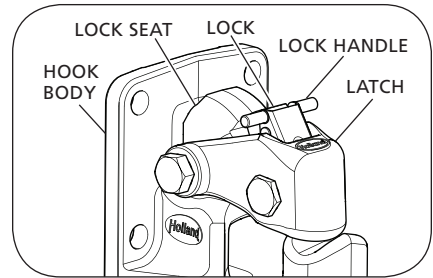

**Figure 17**

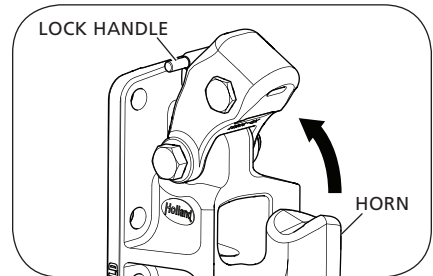

**Figure 18**

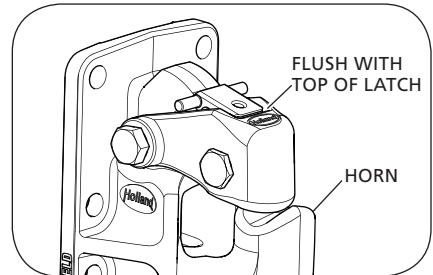

## 10. Maintenance

The following maintenance steps should be performed every 30,000 mi. (48,280 km) or three (3) months, whichever comes first.

**⚠ WARNING** Failure to inspect and maintain the pintle hook could result in separation of the trailer and vehicle which, if not avoided, could result in death or serious injury.

1. Clean and check for proper operation. Inspect for worn, damaged or missing parts. Replace as required using only SAF-HOLLAND® Original parts.
2. Inspect the coupling contact area for wear. Replace the complete product when wear exceeds 0.188" (4.8 mm) from the original surface profile.
3. Additional inspections should be conducted immediately if there is:
  - Overloading
  - Binding of the drawbar upon backing
  - Jackknifing
  - Bottoming of articulation
  - An incident that exceeds the free range of motion of the coupling connection
3. Regularly lubricate the latch pivots with a light oil lubricant.
4. With the latch closed, measure the gap between the hook and the latch while lifting up on the latch. Replace the latch when the gap exceeds 0.38" (9.5 mm) (*Figure 19*).

**⚠ WARNING** Failure to replace a worn latch could result in separation of the trailer and vehicle which if not avoided, could result in death or serious injury.

*Figure 19*

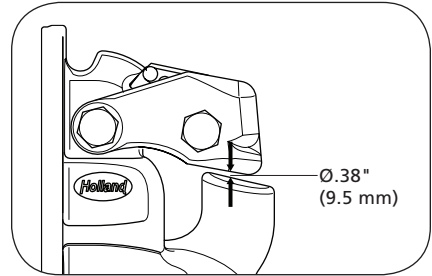

5. Check the mounting fasteners for proper torque, refer to Section 5, page 7.
6. Check the plunger adjustment. For adjustment procedures, refer to Section 8, page 12.

## 11. Replacement Latch Kit (RK-10545 and RK-10545-1)

Immediately replace the latch assembly using RK-10545 (Non Tethered) (**Figure 20**) or RK-10545-1 (Tethered) (**Figure 21**) if the latch gap exceeds .38" (9.5 mm). For measurement description, refer to Section 10, page 14.

**Figure 20**

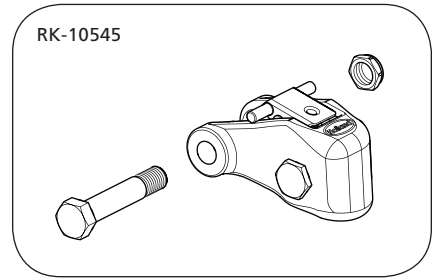

**Figure 21**

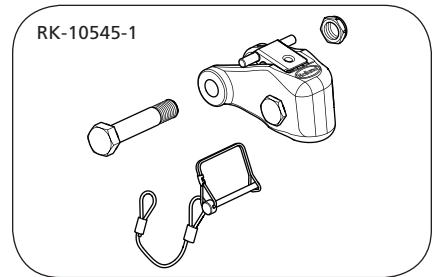



From fifth wheel rebuild kits to suspension bushing repair kits, SAF-HOLLAND Original Parts are the same quality components used in the original component assembly.

SAF-HOLLAND Original Parts are tested and designed to provide maximum performance and durability. Will-fits, look-alikes or, worse yet, counterfeit parts will only limit the performance potential and could possibly void SAF-HOLLAND's warranty. Always be sure to spec SAF-HOLLAND Original Parts when servicing your SAF-HOLLAND product.

**SAF-HOLLAND USA • 888.396.6501 • Fax 800.356.3929**  
**[www.safholland.us](http://www.safholland.us)**

**SAF-HOLLAND CANADA • 519.537.3494 • Fax 800.565.7753**  
**WESTERN CANADA • 604.574.7491 • Fax 604.574.0244**  
**[www.safholland.ca](http://www.safholland.ca)**

**SAF-HOLLAND MEXICO • 52.1.55.5456.8641 • Fax 52.55.58162230**  
**[www.safholland.com.mx](http://www.safholland.com.mx)**

**[info@safholland.com](mailto:info@safholland.com)**

SAF-HOLLAND USA, INC.  
1950 Industrial Blvd., Muskegon, MI 49443  
[www.safholland.com](http://www.safholland.com)

