

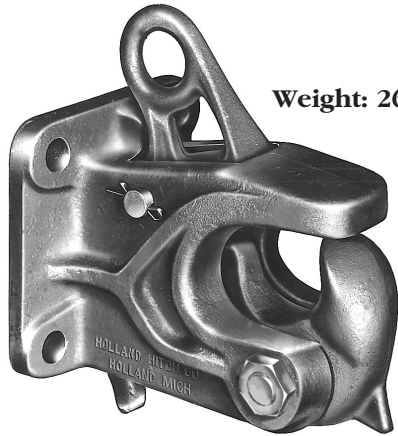

CP-400-H

CP-400-H SPECIFICATIONS



Weight: 26 lbs.



Rigid mount coupler with ring pull release and secondary lock.

7,500 lbs. Maximum Vertical Load
30,000 lbs. Maximum Gross Trailer Weight

IMPORTANT SAFETY INFORMATION

Maintain adequate vertical (tongue) load to adequately control the trailer (generally 10%), but do not exceed the capacity ratings at right.

This equipment must not be used or maintained in a careless manner.

DURING OPERATION

1. Be sure the drawbar size is compatible with the coupling device on the tow vehicle.
2. Do not damage the jaw or release handle. Be particularly careful during coupling and uncoupling.
3. Inspect the coupling device on the tow vehicle for proper operation. Do not use any coupling device that does not operate properly.
4. Other steps and inspections are also required. Consult OSHA and D.O.T. regulations and American Trucking Association for complete coupling and uncoupling procedures. These cover items such as cargo securement, brakes, lights, safety chains, and other important requirements.

GENERAL INFORMATION:

1. Do not modify or add to the product.
2. Wear safety goggles during installation and removal.
3. Never strike any part of the item with a steel hammer.
4. Do not weld on this product.

This product is covered by Holland's Commercial Products Warranty. Holland reserves the right, without giving prior notice, to change specifications and dimensions as designs are altered or improved.

TOWING APPLICATIONS

Industrial material handling applications. This coupler can also be used for towing trailers and equipment designed for over-the-road towing within the stated capacities. For off-road applications, reduce the capacities above by 25% and use in conjunction with a swivel type drawbar.

DRAWBAR EYE DIMENSIONS:

2.44" to 3" I.D. with 1.25" to 1.63" diameter section. Other sizes can be used, provided that they permit proper coupling and are of compatible capacity.

MOUNTING:

1. Use a mounting structure of sufficient strength to support the rated capacity of the coupler in accordance with SAE J849 and SAE J847, respectively.
2. Use the hole pattern described on the reverse.
3. Use (4) .75" grade 8 fasteners, properly tightened.

OPERATING INSTRUCTIONS:

1. Before operating, inspect for proper operation; worn, damaged, or missing parts; and a secure mounting. Correct as required before use.
2. Open coupler jaw (XA-402-X1) by pulling secondary lock (A) away from coupler base and pulling release handle (B) away from mounting base. Coupler jaw can then be rotated down to open.
3. To couple, back near the trailer with the trailer drawbar centered on the coupler. Stop and adjust the drawbar height so it will enter the coupler mouth. Back in slowly to automatically lock coupler to drawbar.
4. Check that the coupler jaw is closed and locked (release handle is fully towards mounting base) and the secondary lock is engaged (lever (A) is fully toward mounting base).

MAINTENANCE:

For proper performance, every 30,000 miles or 3 months – whichever comes first, perform the following:

1. Clean and check for proper operation. Inspect for worn, damaged or missing parts. Replace as required using only Holland parts.
2. Inspect, in particular, the coupling contact area. Replace when wear exceeds 1/8" (0.12") from the original surface profile.
3. Regularly lubricate all pivot points with a light oil lubricant.
4. Check mounting fasteners for proper torque.

CP-400-H

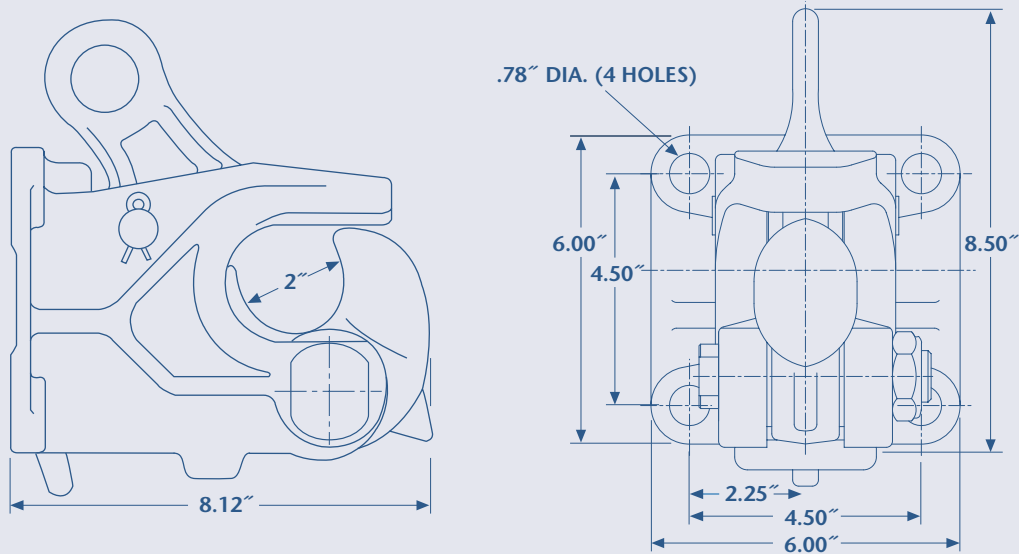

ALL DIMENSIONS SHOWN ARE NOMINAL

***IMPORTANT:**

Add a drop of Loctite permanent thread locker #277 to the threads of the bolt before screwing on the nut, or stake (deform) the exposed threads of the bolt once the nut is tightened into position.

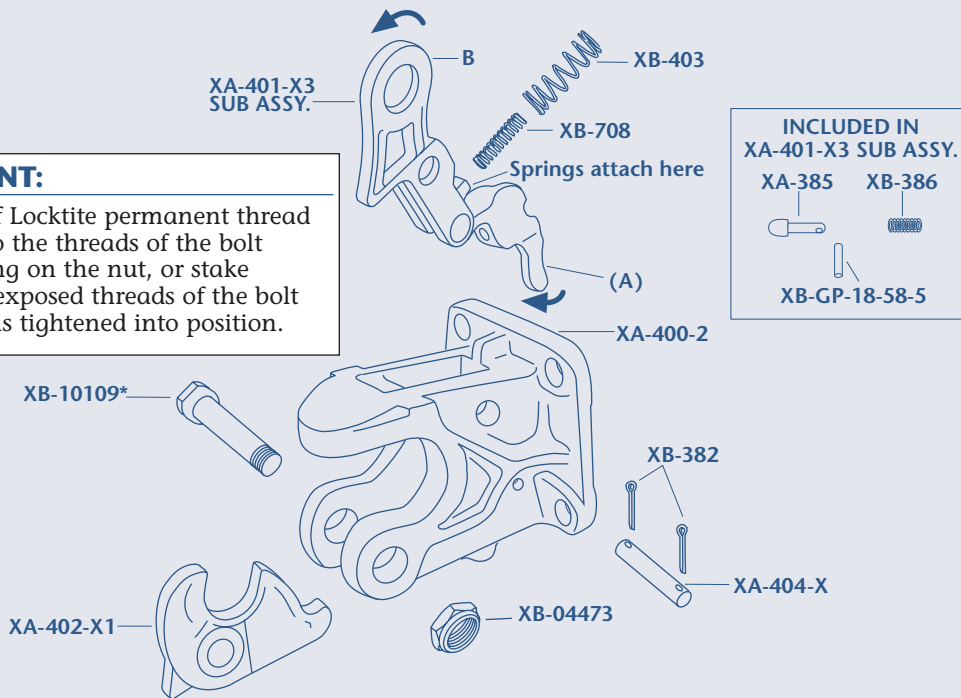

Copyright © July 2002 • The Holland Group, Inc.

Holland USA, Inc. Facilities:
 Denmark, SC Muskegon, MI
 Dumas, AR Warrenton, MO
 Holland, MI Whitehouse Station, NJ
 Milpitas, CA Wylie, TX

Holland International, Inc.
 Holland, MI
 Phone: 616-396-6501
 Fax: 616-396-1511

Holland Hitch of Canada, Ltd.
 Woodstock, Ontario • Canada
 Phone: 519-537-3494
 Fax: 800-565-7753

Holland Equipment, Ltd.
 Norwich, Ontario • Canada
 Phone: 519-863-3414
 Fax: 519-863-2398

Holland Hitch Western, Ltd.
 Surrey, British Columbia • Canada
 Phone: 604-574-7491
 Fax: 604-574-0244

Ph: 888-396-6501 Fax: 800-356-3929